



**AGENDA**  
**SPECIAL MEETING OF THE BOARD OF DIRECTORS**  
**TUESDAY, JANUARY 30, 2018 – 9:00 A.M.**  
**1391 Engineer Street, Vista, CA 92081**  
**Phone: (760) 597-3100**

*In compliance with the Americans with Disabilities Act, if special assistance is needed to participate in the Board meeting, please contact the Board Secretary during regular business hours at (760) 597-3128. Notification received 48 hours before the meeting will enable the District to make reasonable accommodations.*

- 1. CALL TO ORDER**
- 2. ROLL CALL – DETERMINATION OF QUORUM**
- 3. PLEDGE OF ALLEGIANCE**
- 4. CONSIDER APPROVAL OF AGENDA**  
The Board may take action on any item appearing on the agenda.
- 5. PUBLIC COMMENT TIME**  
Public comment time on items not appearing on the agenda will be limited to 5 minutes per person and 15 minutes per subject. The Board may find it necessary to limit total time allowable for all public comment on items not appearing on the agenda at any one meeting to one hour. Persons desiring longer public comment time and/or action on specific items shall contact the Secretary and request that the item be placed on the agenda for the next regular meeting of the Board of Directors.
- 6. WATER MASTER PLAN**  
*Recommendation: Receive informational report on the Water Master Plan.*
- 7. DIRECTOR COMMENTS**  
*This item is placed on the agenda to enable individual Board members to convey information to the Board and the public not requiring discussion or action.*
- 8. COMMENTS BY GENERAL MANAGER**  
*Informational report by the General Manager on items not requiring discussion or action.*
- 9. ADJOURNMENT**

- *The agenda package and materials related to an agenda item submitted after the packet's distribution to the Board, are available for public review in the lobby of the District office during normal business hours.*
- *Agendas and minutes are available at [www.vidwater.org](http://www.vidwater.org).*
- *VID Board meetings are generally held on the first and third Wednesday of each month.*

**AFFIDAVIT OF POSTING**

I, Lisa R. Soto, Board Secretary of the Vista Irrigation District, hereby certify that I posted a copy of the foregoing agenda in the lobby of the District office at 1391 Engineer Street, Vista, California at least 24 hours prior to the meeting, in accordance with Govt. Code Sec. 54956.

Date: January 25, 2018

  
\_\_\_\_\_  
Lisa R. Soto, Board Secretary



## STAFF REPORT

Agenda Item: 6

**Board Meeting Date:** January 30, 2018  
**Prepared By:** Randy Whitmann  
**Reviewed By:** Brett Hodgkiss  
**Approved:** Eldon Boone

SUBJECT: WATER MASTER PLAN

RECOMMENDATION: Receive informational report on the Water Master Plan.

PRIOR BOARD ACTION: On July 20, 2016, the Board authorized the General Manager to enter into an Agreement for Professional Services with HDR Engineering, Inc. for a new Water Master Plan. On January 3, 2018, the Board received an informational report on the Water Master Plan chapters 1 through 3, highlighting the development of the study's land-use based unit demand factors and projected water demands.

FISCAL IMPACT: Unknown at this time. Once finalized, the Water Master Plan will recommend a capital improvement program and prioritization of pipeline replacements and reservoir maintenance; the estimated cost of projects will be incorporated into future budgets.

SUMMARY: A Water Master Plan (Master Plan) is an important planning tool that provides an evaluation of a water system's ability to serve existing and future customers and a phased capital improvement program (CIP) to ensure adequate and reliable service through the projected ultimate build-out of the District's service area. At the January 3, 2018 meeting, District staff provided an overview of draft chapters 1 through 3 of the Master Plan; it was noted that, based on analysis performed by the District's consultant, HDR Engineering, Inc. (HDR), the new build-out projection was considerably less than the projection developed in the 2000 Master Plan. As a result, the new Master Plan's CIP will likely focus on reliability and redundancy, in addition to pipeline replacements, rather than expanding water system capacity.

DETAILED REPORT: HDR will present an overview of draft chapters 4 through 8 focusing on the following areas:

- Planning and Design Criteria – planning and design criteria including standards such as allowable minimum system pressure, maximum pipeline fluid velocity, reservoir storage requirements, and fire flow. These criteria were developed to form the basis for evaluating the District's water system performance and determining facility requirements to serve future development.
- Hydraulic Analysis and Recommended Projects – existing system and ultimate build out hydraulic analyses were performed to review system performance and develop recommended projects.
- Reservoir and Pipeline Condition Assessments – field inspections and pipeline break data analysis were performed to develop reservoir and pipeline condition assessments and recommendations.
- Water Supply – the District's water supply picture and Flume operation were reviewed to develop alternative reliability concepts.

ATTACHMENT: Draft Master Plan Chapters 4 through 8

## 4 Water Supply

The District's water supply originates from two sources: local water and imported water from the Water Authority. Local water from the San Luis Rey River watershed is stored on a seasonal basis in the Lake Henshaw and Lake Wohlford reservoirs. Principal water storage and conveyance facilities include the Warner Basin aquifer, Lake Henshaw, Warner Ranch Well Field, Escondido Canal, Lake Wohlford, Dixon Lake, Bear Valley Pipeline, and EVWTP. A portion of the San Luis Rey River is also used for conveyance. Local water is shared with Escondido and provides approximately 30 percent of the District's average water demand.

The District's use of water from Lake Henshaw dates back to 1926. The lake was purchased by the District, along with the 43,000 acre Warner Ranch, in 1946. Drought conditions and population growth in the late 1940's and early 1950's prompted the District to look for additional sources of water. In 1954, the District became a member of the Water Authority to gain access to water imported from the Colorado River and Northern California. During years when rainfall is significantly below average and the availability of local water is limited, well over 90 percent of the District's water supply can come from imported sources. The historical use of imported water, measured in AF, is illustrated in **Figure 4-1**.

**Figure 4-1. Water Supply to Vista Irrigation District**

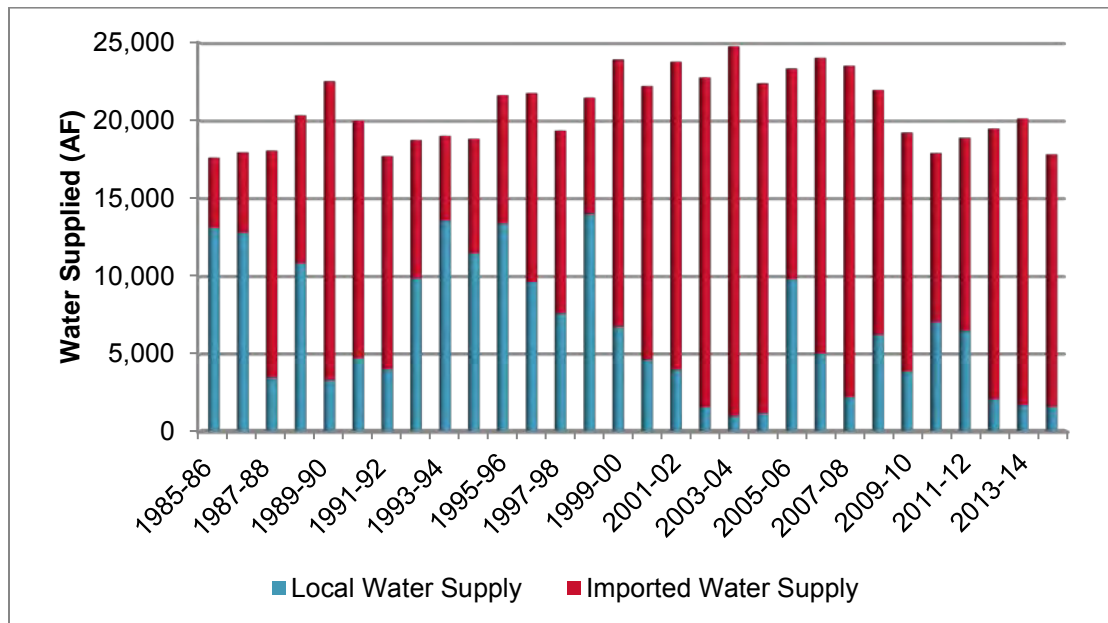

As a result of a long term drought in the Colorado River Basin and environmental constraints associated with the delivery of water from Northern California, the Water Authority was prompted to expand its local water portfolio. The Water Authority began receiving and distributing desalinated seawater from the Claude "Bud" Lewis Carlsbad Desalination Plant to its member agencies, including the District, in December 2015.

This chapter describes the District's water supply system and local water supply facilities.

## 4.1 Local Supply

Water released from Lake Henshaw flows downstream in the San Luis Rey River channel to the intake of the Escondido Canal, which diverts water from the river. The Escondido Canal conveys water to Lake Wohlford, where it is stored and released through the Bear Valley Pipeline to the EVWTP at Lake Dixon. Treated water from the EVWTP is conveyed via the Vista Flume to the District service area. **Figure 4-2** shows the location of these local storage and conveyance facilities, which are further described below.

### 4.1.1 Warner Basin Aquifer

The Warner Basin aquifer is a developed groundwater basin located 50 miles east and north of the District. Total usable storage in the aquifer is estimated to be 400,000 AF; 150,000 AF of active storage volume is located in the aquifer where extraction is feasible using currently operating District wells. The District has 16 production wells that pump from depths of 150 to 350 feet, depending on rainfall and length and extent of pumping operations. Since 1960, the District's median groundwater production has been 7,728 AFY. This water is pumped into Lake Henshaw for surface water storage and subsequent delivery to the District and the City of Escondido.

In dry years, groundwater is pumped from the well field to Lake Henshaw and released as needed. The wells vary in capacity from 300 to 2,000 gallons per minute (gpm). Water is conveyed to Lake Henshaw through about 8 miles of pipeline and 12 miles of lined, open ditches. In wet years, the surface water supply is used and pumping operations cease, permitting the basin to recharge and groundwater levels to rise. Thus, the groundwater basin acts as a water bank, allowing deposits in wet years and withdrawals in dry years.

To date, the Warner Basin aquifer has not been adjudicated nor has it been identified as being in overdraft. In September 2014, the Sustainable Groundwater Management Act was signed into law. The law provides new tools and authorities for local agencies to manage groundwater resources within their jurisdictions to achieve a sustainable use of those resources within a 20-year implementation period. While Sustainable Groundwater Management Act provides specific mandates only for those groundwater basins deemed by the State to be "medium" or "high" priority groundwater basins, the law encourages the formation of "Groundwater Sustainability Agencies" and the preparation of "Groundwater Sustainability Plans" (GSPs) for all groundwater basins, even those deemed "low" and "very low" priority basins.

The California Department of Water Resources has classified the Warner Basin as a "very low" priority basin. Nevertheless, the Warner Basin represents a significant water source for the District. The District continues to investigate groundwater resources in the Warner Basin and the cost/benefit of forming a Warner Valley Groundwater Sustainability Agency.

Figure 4-2. Regional Water Supply Facilities

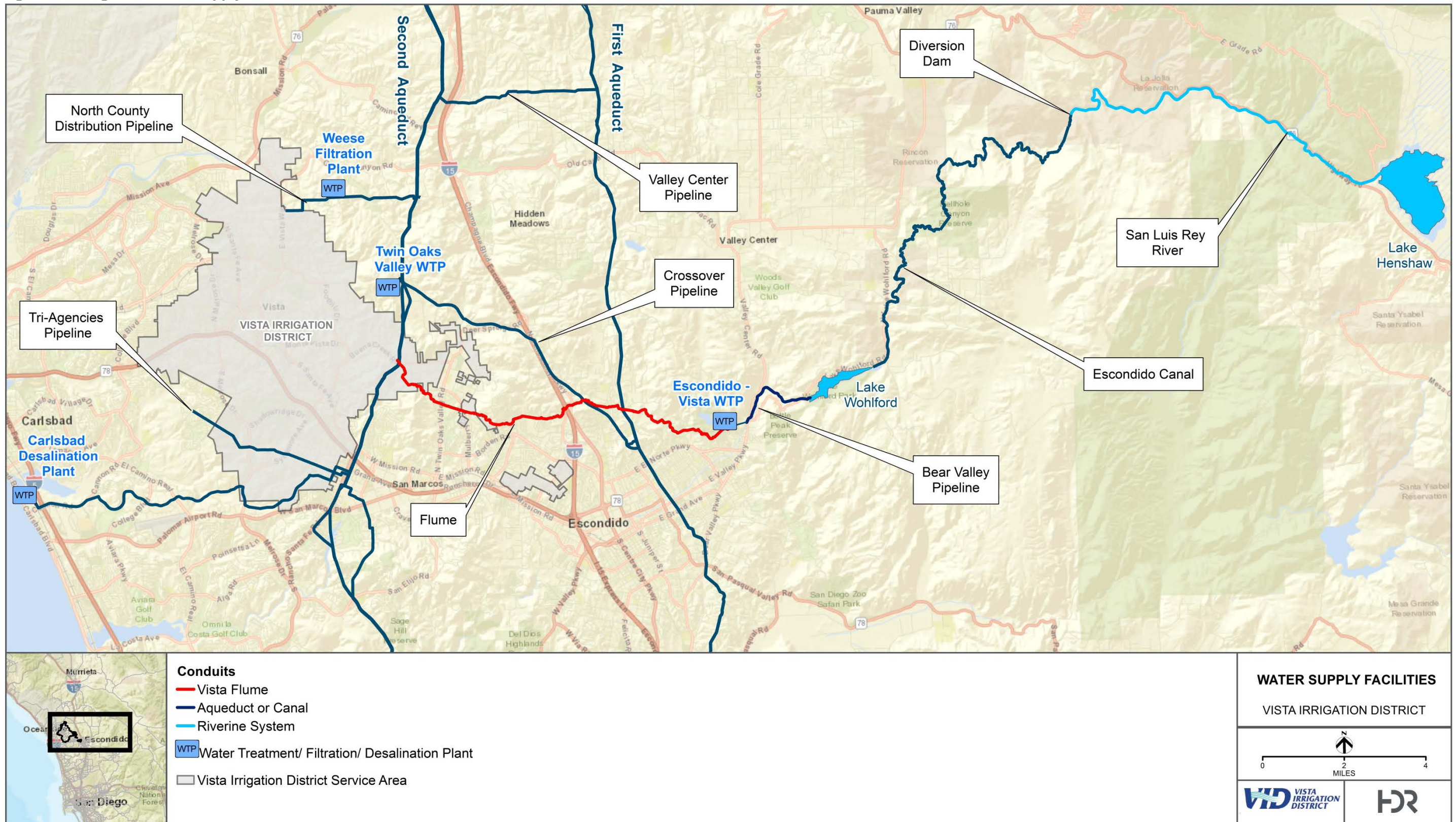

PATH: C:\USERS\JENGLESO\DOCUMENTS\DOCUMENTS\PROJECTS\VISTA\_IRRIGATION\_DISTRICT\2016\_WATER\_MASTER\_PLAN\_UPDATE\_10043046\INFOWATER\VID\_SDCWA\_MAP\_11X17.MXD - USER: JENGLESO - DATE: 1/12/2018

*This page is intentionally blank.*

### 4.1.2 Lake Henshaw

In 1946, the District purchased the Warner Ranch, which included Henshaw Dam and Lake Henshaw. Lake Henshaw was the District's sole supply of water until the formation of the Bueno Colorado Municipal Water District in 1954. The dam and reservoir are owned and operated by the District, and the City of Escondido maintains storage rights. About one third of the 200 square mile watershed is owned by the District and is managed to protect water quality. Lake Henshaw receives, on average, about 30 inches of rain per year. The undeveloped character of the watershed and the District's management activities contribute to the high quality of this local water supply.

Lake Henshaw is a 52,000 AF capacity water supply reservoir located on the San Luis Rey River, about 25 miles east of the District's service area. Lake Henshaw Dam was completed in 1922, enlarged in 1927, and modified in 1981 to comply with California State Division of Safety of Dams requirements. The dam is a zoned hydraulic-fill embankment with an overflow weir spillway on the right abutment.

Both natural runoff developed above Lake Henshaw and groundwater pumped from the Warner Basin are held as surface water in Lake Henshaw. The water is delivered to the District, the City of Escondido, and the Rincon Band of Indians under terms of several governing contracts. While the amount of water delivered to each party is dependent on annual hydrologic conditions, the median local water delivery to the District since 1960, including groundwater production and surface water runoff, is 5,062 AFY.

### 4.1.3 San Luis Rey River

About 9.5 miles of the natural channel of the San Luis Rey River is used to convey water from Lake Henshaw Dam to the intake of the Escondido Canal. The river is enclosed by steep canyon walls and has no maximum conveyance limitations, nor any minimum flow requirements. It is estimated that there is very little seepage from the river, although about 2,500 AFY is absorbed by riparian vegetation or evaporates. On the average, the river catches about 10,000 AFY of additional runoff from adjacent watersheds.

The District has recently resolved litigation initiated in 1969 pertaining to its use of the waters of the San Luis Rey River, including both its Lake Henshaw and Warner Basin groundwater supplies. This litigation, involving the District, the City of Escondido, five local Indian Bands, and the federal government, was resolved when the Settlement Agreement approved by the parties became effective on May 17, 2017. Under the Settlement Agreement, Escondido and the District are allowed to develop, divert, and use the waters of the San Luis Rey River basin (Local Water) substantially as they have in the past. Under the Settlement Agreement, the federal government has agreed to furnish 16,000 AFY of water conserved from the lining of the All American and Coachella Canals (referred to as Supplemental Water) to the Settlement Parties (the District, the City of Escondido, and the five Indian Bands). Other agreements provide for the wheeling of Supplemental Water through facilities owned by MWD and the Water Authority for use either on the reservations of the five Bands, or within the service areas of the District or the City of Escondido.

Under the Settlement Agreement, the District and the City of Escondido continue to pay for and enjoy the benefits of Local Water and the five Bands pay for and enjoy the benefits of the Supplemental Water. Any Supplemental Water that is surplus to the needs of the five Bands will be delivered in equal measure to the District and the City of Escondido, which are required to take delivery of such water and pay the Bands what they would otherwise have paid the Water Authority for that same quantity of water. Additionally, any of the five Bands may elect to exchange an acre-foot of Local Water delivered from the local water system operated by Escondido and the District for an acre-foot of Supplemental Water delivered to Escondido and the District. This last measure provides for water delivery to Bands' reservations that may not have access to imported water, or who may prefer the delivery of untreated water.

#### 4.1.4 Escondido Canal

The Escondido Canal was first constructed in 1895. A small diversion dam routes water in the San Luis Rey River into the Escondido Canal for delivery to Lake Wohlford, about 14 miles distant. The canal and diversion dam were improved and enlarged in 1924 to take advantage of increased deliveries made possible by the construction of Henshaw Dam. The diversion dam is a 16 foot high concrete gravity structure with an integral canal intake facility at the left end. There is an ungated overflow weir with 13,000 cubic feet per second (cfs) of capacity.

Current operational capacity of the Escondido Canal is 50 cfs. The canal is owned and operated by the City of Escondido, although the District has capacity rights. The canal traverses about 14 miles of rugged terrain and consists of 11.1 miles of shotcreted canal, 1.6 miles of pipeline, 0.7 mile of tunnel, and 0.1 mile of metal flume. It terminates in Escondido Creek at the north end of Lake Wohlford.

#### 4.1.5 Lake Wohlford Dam and Reservoir

In 1895, a 2,800 AF impoundment was created by the construction of a rock-fill dam on Escondido Creek, originally called the Bear Valley Dam, to receive the waters delivered through the Escondido Canal. In 1924, in conjunction with the construction of Henshaw Dam and the enlargement of the Escondido Canal, the dam was completely rebuilt as a hydraulic-and-rock-fill structure with a maximum storage capacity of 6,460 AF.

In 2007, the Federal Energy Regulatory Commission began requiring that Lake Wohlford water level be maintained at least 20 feet below the spillway crest level for dam safety purposes, thus limiting the capacity to 2,800 AF. The City of Escondido has completed several studies for the Lake Wohlford Dam Replacement Project and plans to replace the existing dam structure with a new roller compacted concrete dam to utilize the full storage capacity.

Most of the water released from Lake Wohlford passes through the 75 cfs capacity Wohlford Penstock to the Bear Valley Hydroelectric Generation Facility, which has a capacity of 50 cfs. The District maintains a bypass line to directly divert the excess 25 cfs when necessary. Lake Wohlford is also used as a recreational facility.

#### 4.1.6 Bear Valley Pipeline

The Bear Valley Pipeline was originally constructed as two 43 cfs pipelines, one each for the City and the District. In the early 1990s, these pipelines were partially replaced with a single 54-inch diameter pipeline from the Bear Valley Hydroelectric Plant to the intersection of Lake Wohlford Road and Foxley Lane.

#### 4.1.7 Lake Dixon Dam and Reservoir

Lake Dixon Dam was completed in 1970 and is a zoned earth-fill embankment. With a total capacity of 2,610 AF, Lake Dixon Reservoir is primarily used to store imported water. There is no significant delivery of local water to Lake Dixon.

#### 4.1.8 Escondido-Vista Water Treatment Plant

The EVWTP treats raw water from wholesale and local sources before it is delivered to District customers. Water flows by gravity from Lake Dixon at a maximum instantaneous flow rate of 80 MGD and enters the EVWTP through a 54-inch pipeline. Water may also enter from the 42-inch Water Authority Crossover Pipeline with a fluctuating flow. Maximum inflow from Lake Wohlford is approximately 50 MGD. Local water is blended with imported water prior to treatment.

The EVWTP was completed in 1975 and expanded in 1984. Designed for 90 MGD, the EVWTP is currently permitted to produce 75 MGD due to restrictions placed by the Department of Health on the plant's filtration system. Treatment includes coagulation, sedimentation, filtration, and disinfection to ensure drinking water quality. Bacteriological, physical, and chemical tests are performed on water samples to assure that safe water for customers is being produced and maintained in the distribution system. Treated water is delivered either to the EVWTP Clearwell and then to Escondido's distribution system or to the Vista Flume for delivery to the District. The District owns capacity rights for treatment of 18 MGD; Escondido owns the remainder.

#### 4.1.9 Vista Flume

The District's portion of treated water from the EVWTP is conveyed to the District's Pechstein Reservoir via an 11-mile conduit that includes both flume and siphon conveyance systems. The Vista Flume is owned, operated, and maintained by the District. The flume portion of the alignment totals 5.5 miles in length and consists of 11 bench sections. The siphon system is 5.75 miles in length and is comprised of five riveted steel sections, three concrete sections, one high density polyethylene (HDPE) section, and a 0.25-mile-long hard rock tunnel (Big Tunnel) section.

The flumes were constructed with a very uniform vertical grade approximating 1 percent throughout. The horizontal bending of the flumes is often quite severe to match the terrain needed to obtain the uniform vertical grade and includes numerous compound and compound reverse curves of minimal radius. Gravity flow through the existing flumes that are lined on the floor and walls with a HDPE sheet lining system can currently convey approximately 20 MGD.

## 4.2 Water Authority Supply

Depending on the availability of local water, the District obtains as much as 90 percent of its potable water supply from the Water Authority. The Water Authority is one of the largest of 26 member agencies of MWD. MWD was formed in 1928 to develop, store, and provide wholesale distribution of supplemental water in southern California for domestic and municipal purposes. MWD's supplies come from two primary sources, the State Water Project, owned and operated by the California Department of Water Resources, and the Colorado River, via the Colorado River Aqueduct, as shown in **Figure 4-3**. Historically, the Water Authority has relied on imported water supplies purchased from MWD to meet the needs of its 24 member agencies.

After experiencing severe shortages from MWD during the 1987–1992 drought, the Water Authority began aggressively pursuing actions to diversify the region's supply sources. To reduce its dependency on MWD and diversify its supplies, the Water Authority undertook several initiatives, including the following:

- **Carlsbad Seawater Desalination Water Purchase Agreement:** To further help diversify regional supplies, the Water Authority entered into a Water Purchase Agreement under which it agrees to purchase up to 56,000 AFY of desalinated water from the Claude “Bud” Lewis Carlsbad Desalination Plant, which became operational in December 2015.
- **Imperial Irrigation District Transfer:** The Water Authority signed a Water Conservation and Transfer Agreement with Imperial Irrigation District in 1998. Through the transfer agreement, the Water Authority is purchasing water from Imperial Irrigation District at volumes that will gradually increase year to-year, reaching 200,000 AFY in 2021. The water is physically delivered to San Diego via MWD's Colorado River Aqueduct.
- **All-American and Coachella Canal Lining Conserved Water:** In 2003, as part of the execution of the Quantification Settlement Agreement on the Colorado River, the Water Authority was assigned rights to 77,700 AFY of conserved water from projects to line the All-American and Coachella Canals. These canal lining projects are now complete and the Water Authority is receiving this water. As with the Imperial Irrigation District transfer water, the water is physically delivered to San Diego via the Colorado River Aqueduct.
- **Water Transfer and Banking Programs:** In addition to the above, the Water Authority has entered into water transfer and water banking arrangements with Central Valley area agricultural agencies and groundwater storage interests. These projects are designed to make additional water available to the Water Authority during dry-year supply shortages from MWD.

Figure 4-3. Major Water Conveyance Facilities in California



Source: Metropolitan Water District of Southern California (MWD). 2015.

[http://www.mwdh2o.com/Who%20We%20Are%20%20Fact%20Sheets/6.4.2\\_Maps\\_Major\\_Water\\_Conveyance.pdf](http://www.mwdh2o.com/Who%20We%20Are%20%20Fact%20Sheets/6.4.2_Maps_Major_Water_Conveyance.pdf)

In the early 1990s, recognizing the potential for a large earthquake or other emergency condition to cause a sustained outage of the pipelines, the Water Authority initiated the Emergency Storage Project (ESP) to safeguard against this risk. The primary objective of the ESP is to develop an emergency storage and delivery system able to provide 75 percent of 2-month peak water demand for all water users in the service area. This is referred to as the “2-month” emergency event. The major facilities of the ESP include the Olivenhain Reservoir and pipeline, the Hodges-Olivenhain Connection, the San Vicente Dam enlargement, and San Vicente–Miramar Pipeline, as shown in **Figure 4-4**. The largest components of the ESP facilities are now completed or nearing completion.

Figure 4-4. Emergency Storage Project

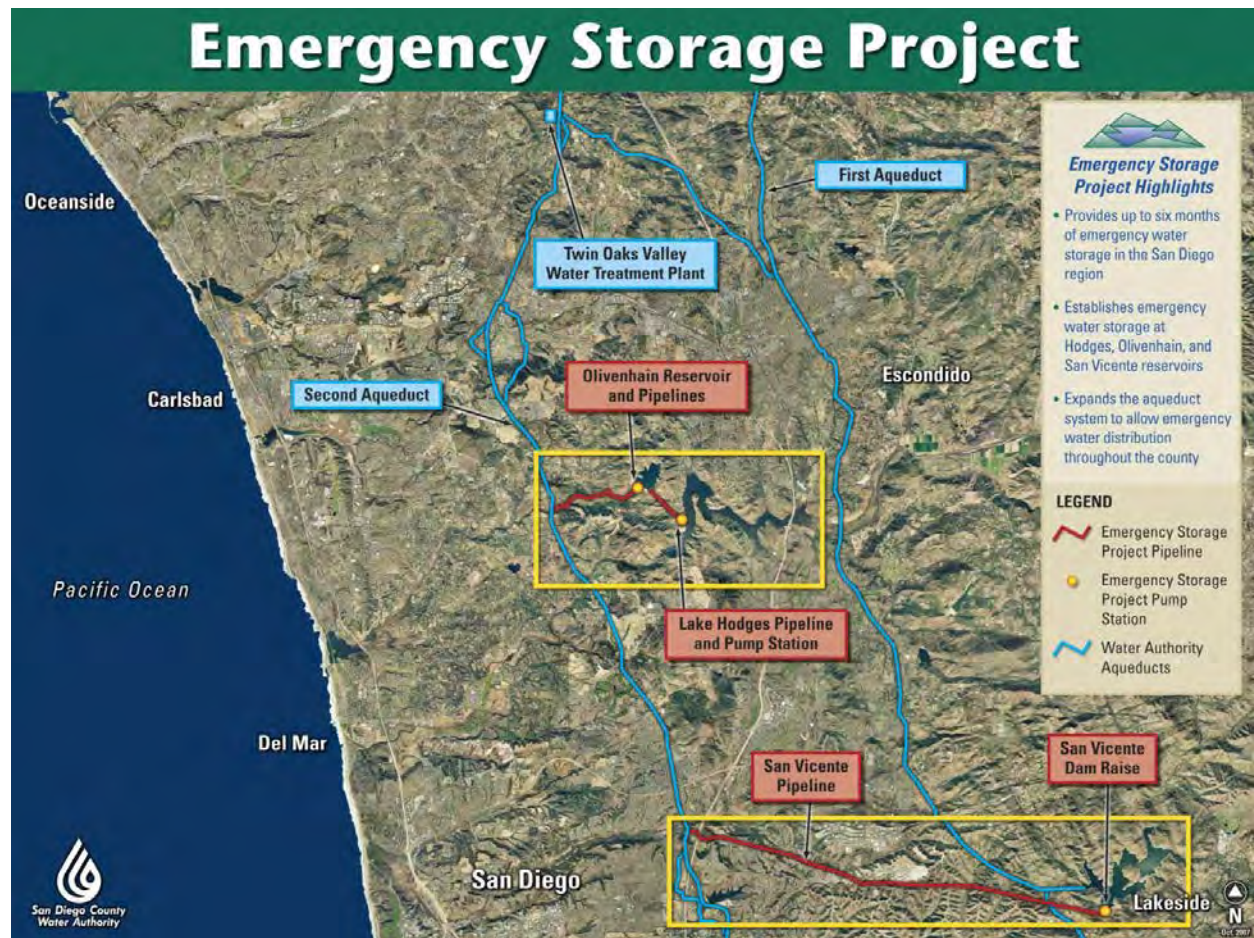

Source: The Water Authority (2017) <https://www.sdewa.org/sites/default/files/images/projects-facilities-ops/esp/esp-county-map-2.jpg>.

The Water Authority delivers treated and raw water from the State Water Project and the Colorado River into San Diego County through five large diameter pipelines, located in two principal corridors known as the First and Second San Diego Aqueducts. The system has evolved over time to serve the growing needs of the service area. The aqueduct pipelines connect to both filtered and raw water feeds from MWD facilities at Lake Skinner, in southern Riverside County.

The First Aqueduct, Pipelines 1 and 2, delivers filtered water to the northeastern portion of San Diego County. Prior to 1992, Pipelines 1 and 2 provided raw water to the City of

Escondido. In March 1992, the Water Authority converted the northerly portion of Pipelines 1 and 2 to deliver filtered water, and connected the southern portion of Pipelines 1 and 2 to a different raw water supply: Pipeline 5, via a cross-over pipeline, which provides a source of supply for the EVWTP. Currently, delivery of filtered water from Pipelines 1 and 2 ends at the delivery points to the District and Rincon del Diablo Municipal Water District and the Hubbard Hill Overflow.

The Water Authority's Second Aqueduct is located west of the First Aqueduct and includes Pipelines 3, 4 and 5. Pipeline 5 delivers raw water and Pipeline 4 delivers filtered water from MWD's Lake Skinner Water Treatment Plant (WTP). As part of the incorporation of the Carlsbad Desalination Plant facilities, the Water Authority converted Pipeline 3 to convey the treated water northward to the Water Authority's regional facilities in Twin Oaks Valley. From there, this new supply blends with existing imported supplies in Pipeline 4 to enhance the reliability regionally, as shown in **Figure 4-5**. Currently there is no independent connection for the District to access desalinated water, although one is being planned for the City of Carlsbad.

**Figure 4-5. Pipeline 3 Desalination Conversion**

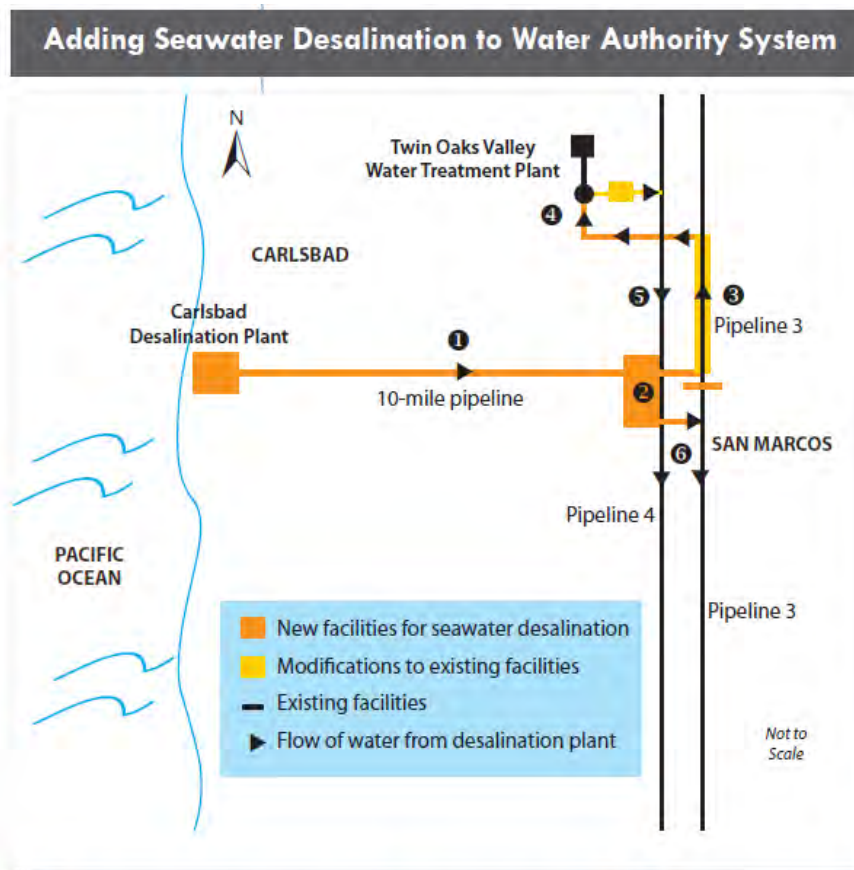

- ① Desalinated seawater flows to San Marcos in new pipeline.
- ② New pipeline control facilities send water north into Pipeline 3.
- ③ Upgraded Pipeline 3 delivers water to regional hub at Twin Oaks.
- ④ Improvements at Twin Oaks plant blend desalinated water with existing treated water supplies.
- ⑤ Water flows south in Pipeline 4 to control facility ② and then continues southward into Pipelines 3 and 4.
- ⑥

Source: <http://www.sdcwa.org/sites/default/files/pipeline3-desal-relining-FS.pdf>

## 4.3 Water Authority and Interagency Connections

The District maintains six flow control facility connections to the Water Authority Aqueducts delivering filtered water, as shown on **Figure 4-6** and in **Table 4-1**.

**Table 4-1. District Water Supply Connections**

Connection	Aqueduct and Feed	Capacity (cfs)	Capacity (MGD)
VID 1	First Aqueduct, Pipelines 1 and 2	10	6.5
VID 3	Second Aqueduct, Pipelines 3 and 4	30	19.4
VID 8	Second Aqueduct, Tri-Agency Pipeline, Pipelines 3 and 4	5	3.2
VID 9	Second Aqueduct, Tri-Agency Pipeline, Pipelines 3 and 4	20	13.0
VID 10	Second Aqueduct, Tri-Agency Pipeline, Pipelines 3 and 4	15	9.7
VID 11	Second Aqueduct, North County Distribution Pipeline, Pipeline 4, Weese WFP	50	32.3

cfs – cubic feet per second; MGD – million gallons per day; VID – Vista Irrigation District; WFP - Water Filtration Plant

In addition to its primary supply connections to the Water Authority Aqueducts, the District also has emergency connections to neighboring water agencies. These interconnections allow the District to be supplied by its neighbors during times when its supply from the Water Authority is interrupted. In some cases, the interconnections also allow the District to reciprocate by providing water to a neighboring agency should the need arise. These connections are shown in **Figure 4-6** and are described in **Table 4-2**.

The City of Oceanside Water Utilities Department purchases imported raw water from the Water Authority and treats it at the 25 MGD Robert A. Weese (Weese) Filtration Plant (WFP). The District's intertie with Oceanside provides the District with a potential access to this locally treated water in the event of an emergency outage of the District's other water supplies.

VWD and the City of Carlsbad have or are planning to construct connections to the Desalination pipeline. Interagency connections with these neighboring agencies may provide the District with emergency access to desalinated water supply sources if the Water Authority Aqueducts are out of service.

Figure 4-6. Water Authority and Interagency Connections

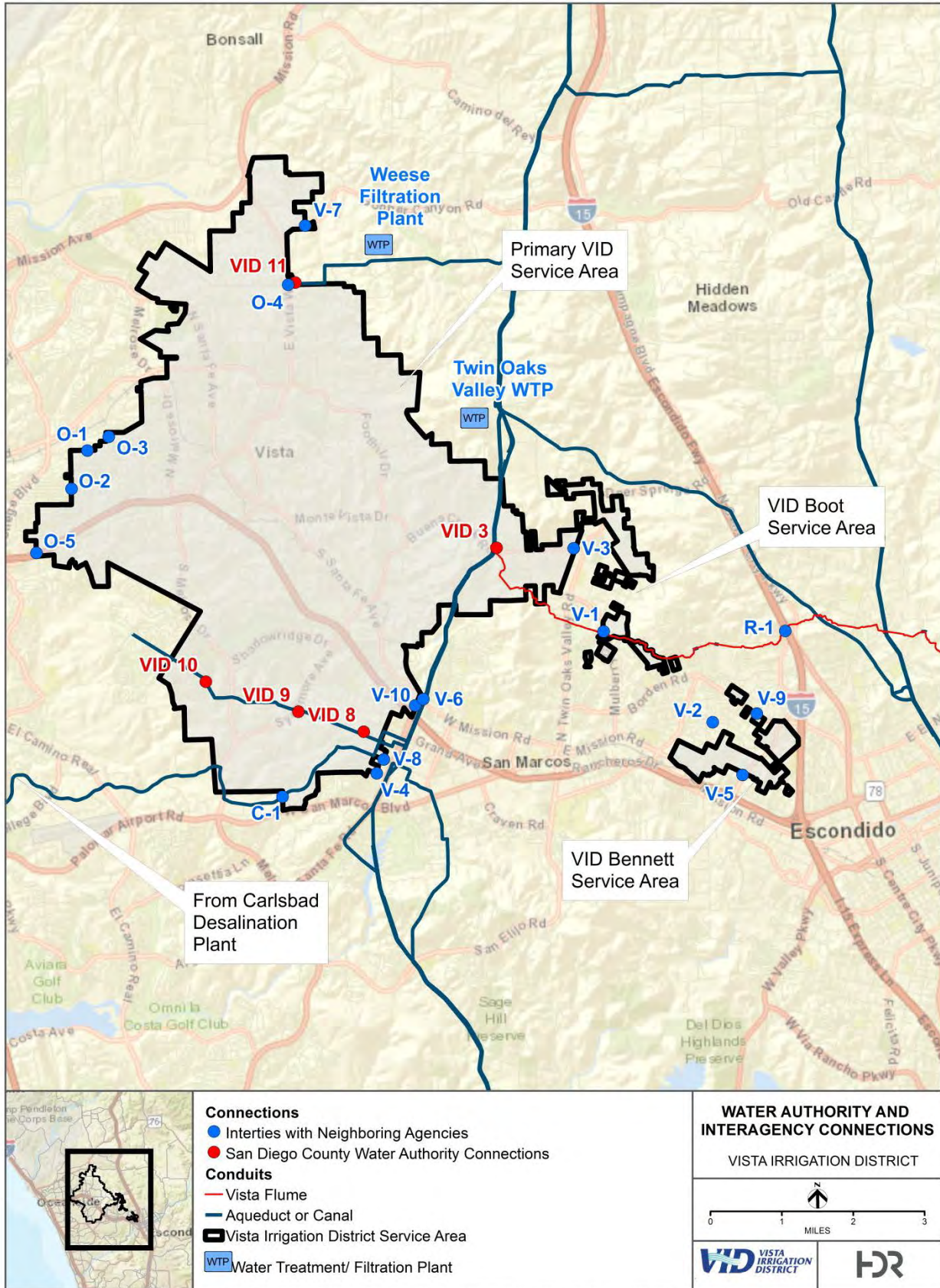

**Table 4-2. Interagency Connections**

Map ID (See Figure 4-6)	Location	Connecting Agency	Type	Year Installed	Pipe Size (Inches)	Meter Size (Inches)	Service From	Service To	VID Zone	Connecting Agency Zone	Approx. Flow Rate (gpm)
O-1	Fall Place and Olive Avenue	Oceanside	Supply	1985	6	6	VID	Oceanside	565	511	500
C-1	Lionshead and Poinsettia Avenues	Carlsbad	Supplement	2005	8	6	Carlsbad	VID	707	700	750
R-1	Nutmeg Street at Caldwell Siphon	Rincon del Diablo Municipal Water District	Supplement	1993	8	8	Rincon del Diablo Municipal Water District	VID	Flume (899')	1000	500
V-1	Mulberry Drive and Woodward Street	VWD	Supplement	1995	6	6	VWD	VID	850	920	500
O-2	561 Emerald Drive	Oceanside	Emergency	1983	6	Closed GV	Oceanside	VID	486	600	500
O-3	853 Granada Drive	Oceanside	Emergency	1979	8	8	VID	Oceanside	565	526	500
O-4	Osborne Street and East Vista Way	Oceanside	Emergency	1971	10	Closed GV	VID	Oceanside	810	511	1,000
O-5	Thunder Drive and West Vista Way	Oceanside	Emergency	1963	6	Closed GV	Oceanside	VID	486	511	500
V-2	1440 Rocksprings Road	VWD	Emergency	1959	6	Closed GV	VWD	VID	980	920	500



**Table 4-2. Interagency Connections**

Map ID (See Figure 4-6)	Location	Connecting Agency	Type	Year Installed	Pipe Size (Inches)	Meter Size (Inches)	Service From	Service To	VID Zone	Connecting Agency Zone	Approx. Flow Rate (gpm)
V-3	215 Buena Creek Road	VWD	Emergency	1968	10	8	VWD	VID	976/ 984	1,028	2,000
V-4	3870 First Street	VWD	Emergency	1970	6	Closed GV	VWD	VID	837	855	500
V-5	851 Nordahl Road	VWD	Emergency	1990	10	Closed GV	VWD	VID	980	920	500
V-6	Capalina and Rancho Santa Fe	VWD	Emergency	1971	8	Closed GV	VWD	VID	837	855	500
V-7	Fairview Drive and Gopher Canyon Road	VWD	Emergency	2003	8	6	VWD	VID	810	900	500
V-8	Linda Vista Drive (VWD Reg. Vault)	VWD	Emergency	1995	8	6	VWD	VID	837	920	500
V-9	Rees Road and El Norte Parkway	VWD	Emergency	1995	8	6	VWD	VID	898	920	1,000
V-10	South Santa Fe and Rancho Santa Fe	VWD	Emergency	2006	8	6	VWD	VID	837	920	500

gpm – gallons per minute; GV – gate valve; VID – Vista Irrigation District; VWD - Vallecitos Water District

## 4.4 Supply Reliability – Water Shortage Events

The Water Authority conducts scheduled shutdowns of sections of its regional water supply pipeline for internal inspection, maintenance, and capital improvements on an annual basis. These shutdowns are typically scheduled during low demand, winter months, although early fall shutdowns do occasionally occur. The District and other member agencies receive advanced notice of these planned shutdowns so that they can be prepared to serve their customers using alternative supply sources or stored water. In 2005, shutdowns to both the First and Second Aqueducts occurred simultaneously, precluding the District from relying on its connections to either the First or Second Aqueduct.

The Water Authority recommends that its member agencies maintain 10 days of storage or alternative supply in order to be self reliant during routine maintenance on the aqueducts. With the exception of emergencies, the maintenance typically occurs during winter months when demands are low. Minimum day demands (MinDD) are typically 50 percent of the AAD. As discussed in **Chapter 3**, the District's current AAD is approximately 17 MGD, and projected buildout is 20 MGD. With a MinDD of 8.5 to 10 MGD, 10 days of storage would require the District to have 85 to 100 MG of storage capacity. The District currently has just over 40 MG of storage capacity.

To offset a planned outage of the Water Authority aqueducts, the District relies on its capacity rights for 18 MGD at the EVWTP, which can be conveyed to the District via the Vista Flume. Meeting a 10-day outage of the Water Authority aqueduct by depending on the District's local supply via the Vista Flume has been sufficient to meet the Water Authority independence criteria. However, if the Vista Flume were out of service, the District would rely on its 40 MG of storage capacity, which would only provide 4 to 5 days of supply. Storage supplies could potentially be supplemented through connections with neighboring agencies that have excess storage or independent water supplies.

If the Vista Flume were out of service under buildout maximum day conditions, the District would be dependent on Water Authority for approximately 40 MGD, or 62 cfs of supply. Assuming that an outage of the Vista Flume would preclude the use of the District's connection to the First Aqueduct (VID 1), the District would depend on its five connections to the Second Aqueduct. These connections, as described in **Section 4.3**, have a total capacity to deliver over 100 cfs, which is sufficient to offset supply from the Vista Flume. The Boot and Bennett areas would need to be served by interagency connections with VWD and/or Rincon del Diablo Municipal Water District.

**Table 4-3** summarizes the types of water shortage events that could affect the District, the assets currently available to the District to address the shortage event, and the consequences of each event to the District with existing assets. **Section 4.5** expands on the District's opportunities to enhance supply reliability should the Vista Flume be out of service.

**Table 4-3. Summary of Potential Shortage Events and Consequences**

Event Existing	Frequency	Duration	Response Assets	Consequence
<p><b>1) Drought</b> (or other prolonged reduction in imported water supplies and local resources)</p>	<p>Unknown (Imported delivery reliability is dependent on State, MWD, and Water Authority actions)</p>	<p>1 year and longer</p>	<p>a) State, MWD, and Water Authority response capabilities b) District drought response ordinance and rate structure</p>	<p><b>Significant</b> (Cutbacks to District treated water customers at same level as Water Authority cutbacks to District)</p>
<p><b>2) ESP Event</b> (Earthquake induced or other failure of all or most of the San Diego Aqueduct pipelines)</p>	<p>Low (on the order of one event per 100 years)</p>	<p>2 months (per ESP design criteria, based on aqueduct repair time estimates)</p>	<p>a) EVWTP via the Vista Flume b) Water Authority ESP facilities, Carlsbad Desalination Plant and Twin Oaks WTP c) District Treated Water Storage d) District interties with neighboring agencies e) District Water Shortage Contingency Plan</p>	<p><b>Moderate</b> (No Water Authority deliveries for 4 to 7 days; thereafter deliveries at minimum 75% level of service)</p>
<p><b>3) Treated Water Shutdown of First and/or Second Aqueducts</b> (planned event)</p>	<p>Annually (approximately)</p>	<p>10 days (typically during winter months)</p>	<p>a) EVWTP via the Vista Flume b) District Treated Water Storage c) District interties with neighboring agencies</p>	<p><b>Minor</b> (Possible drawdown of District storage to below preferred levels)</p>
<p><b>4) Outage of EVWTP or Vista Flume</b></p>	<p>Low (on the order of one event per 50 years, assuming ongoing maintenance and rehabilitation of the Vista Flume)</p>	<p>2 to 6 months (based on repair time estimates)</p>	<p>a) Water Authority Aqueduct and ESP facilities, Carlsbad Desalination Plant and Twin Oaks WTP b) District interties with neighboring agencies c) District Water Shortage Contingency Plan</p>	<p><b>Moderate</b> (No deliveries from EVWTP or First Aqueduct for duration)</p>

ESP – Emergency Storage Project; District - Vista Irrigation District; EVWTP - Escondido-Vista Water Treatment Plant; MWD - Metropolitan Water District of Southern California; Water Authority – San Diego County Water Authority; WTP – water treatment plant

## 4.5 Assessment of Water Reliability Improvement Concepts

The District has connection capacity to the Water Authority aqueduct system and the EWTP, via the Vista Flume, that significantly exceeds its current and projected AAD. This surplus capacity provides operational flexibility to accommodate peaking and to allow for one or more of the District's aqueduct connections to be off-line. However, given the age and current condition of the Vista Flume, the District has concerns regarding the long term viability of this important conveyance system.

As documented in the *Historic American Engineering Level Written Documentation - Vista Irrigation District Main Water Conveyance* prepared for the District in November 2016, the Vista Flume was originally constructed in 1926 and underwent a significant repair and maintenance program in 1947 through 1955. During that time, 7 miles of the flume were covered with a reinforced concrete arch and 4 miles of steel siphon sections were lined with concrete mortar. In the 1980s, repairs to the cover were made and HDPE liners were installed to reduce seepage. Inspections in the 1990s noted seepage at the bench sections and overall susceptibility of the flume to service interruption from rock slides or seismic activity. In 2005, upgrades were made to the bench sections and, in 2010, the District successfully conducted a pilot project to line the MW Bench with HDPE pipe.

In March of 2012, the District conducted a condition assessment of the flume, as well as a cost of water evaluation. The study concluded that rather than rehabilitation of the flume bench sections with HDPE pipe, the District's least expensive option was to internally repair the roofs with grout, which would extend the flume's life 20 to 30 years. The study's estimated cost for this work was approximately \$4 million (\$140/foot). The study also recommended relining all the siphons, with an estimated cost of \$7 million (\$230/foot).

Following the study, the District has pursued the recommended roof repairs and found it difficult to obtain bids for such work. Additionally, the repairs do not address the ongoing maintenance required on the existing HDPE liner and exterior portions of the flume, where cracking between the roof and walls is prevalent. As such, the District considers the internal roof repair recommendations to only be a partial and short-term solution, where full slip-lining or replacement would be an appropriate avenue for the long-term.

The District has recently been involved in additional flume projects, including an HDPE slip-line design for the Meyer's Siphon, relocation, and replacement construction of the Baumgartner Bench and Siphon with a new HDPE siphon, and an alternatives study for the rehabilitation/replacement of the Beehive Bench and Siphon. Based on these recent rehabilitation/replacement projects, the District has found a wide range of unit costs associated with long-term solutions for the Vista Flume. The actual cost to relocate the Baumgartner Bench and Siphon with a new 42-inch HDPE siphon, as part of a new residential development, was approximately \$500/foot. Estimated costs to HDPE slip-line or epoxy line the Meyer's and Beehive Siphons are between \$800 and \$1,000/foot, and the range to rehabilitate or replace the Beehive Bench is between \$1,500 and \$1,900/foot. This all equates to an expensive price tag for a long-term

rehabilitation or replacement solution for the entire remaining 10 miles of the Vista Flume (projected between \$36 and \$75 million).

Given the potential costs to replace the Flume, this section explores water supply reliability improvement opportunities that could potentially offset a short-term outage or permanent abandonment of the Vista Flume.

#### 4.5.1 Opportunities to offset a 10-day Aqueduct Outage

As noted in the **Section 4.4**, meeting a planned 10-day outage of the Water Authority aqueduct systems by depending on the District's local supply via the Vista Flume has been sufficient to meet the Water Authority independence criteria. However, if the Vista Flume were out of service, the District's 40 MG of storage capacity would provide only 4 to 5 days of supply during winter (minimum) day demands. If the Vista Flume were out of service for a longer period of time, the District would be primarily reliant on Water Authority service connection VID 3 to directly serve the District's highest zones. Outage of the Vista Flume also precludes the District from access to the Water Authority's First Aqueduct system at VID 1.

Opportunities to mitigate outage of the Vista Flume during a planned 10-day aqueduct outage include the following:

##### New Water Authority Isolation Valve(s) on Second Aqueduct's Treated Water System

Pipeline 4, the sole treated water pipeline of the Second Aqueduct north of the Twin Oaks Diversion Structure, is subject to occasional planned shutdowns for inspection, maintenance, and installation of new connections. The Water Authority provides an updated Annual Operating Plan in June to reflect anticipated operational opportunities and constraints for the upcoming FY, and to evaluate performance for the prior FY. The Annual Operating Plan includes the Water Authority's anticipated operating schedules and WTP outages. The Annual Operating Plan is developed based on information received from member agencies, historical delivery/production data, capacity constraints within the Water Authority's aqueduct system, and scheduled shutdowns. For FY 2018, the Water Authority had one planned outage of the entire Second Aqueduct's treated water system, between November 5 and 14, 2017. The primary reason for the shutdown was to support activities related to asset management and warranty inspections of the Carlsbad Desalination Plant.

During Second Aqueduct treated water shutdown events, the District relies on the Vista Flume to deliver supply from the VID 1 connection to the First Aqueduct and treated water from EVWTP. In addition, VID 11 can deliver treated water from the Weese WFP.

The Water Authority's Twin Oaks WTP provides a possible additional means of supplying water to the District during a treated water aqueduct shutdown. The plant receives raw water from Pipelines 3 and 5, and then treats the water for delivery back to Twin Oaks Diversion Structure and hence into the treated water aqueduct pipelines south of Diversion Structure. However, during a treated water shutdown, if Pipeline 4 north of the Diversion Structure is drained for inspection or maintenance, the plant cannot deliver back to the Diversion Structure without flooding Pipeline 4 to the north, and therefore cannot operate during this situation. Likewise, desalinated water from the Carlsbad

Desalination Plant is conveyed to this Diversion Structure prior to being introduced to Pipeline 4, and therefore is also unavailable during a Pipeline 4 shutdown.

In FY 2008, the Water Authority considered installing an isolation valve in Pipeline 4 just north of the Twin Oaks WTP and just south of the North County Distribution Pipeline connection, to allow the Twin Oaks and Carlsbad Desalination Plants to operate during a Pipeline 4 shutdown. This isolation valve would also allow treated water in Pipeline 4 to continue to serve the North County Distribution Pipeline, including VID 11, in the event that maintenance on the Carlsbad Desalination and Twin Oaks facilities required shut down.

Another potential option would be to install isolation valves between Twin Oaks WTP and the Carlsbad Desalination Plant. This could give the Water Authority additional operational flexibility and allow VID 3 and/or the Tri-Agencies Pipeline to remain in service.

Any of these valve options could greatly reduce the consequences of a Second Aqueduct treated water system shutdown. Because of the important benefit that this would provide the District, as well as other Water Authority member agencies, it is recommended that the District encourage the Water Authority to pursue any aqueduct or treatment facility projects that provide operational flexibility and eliminate the need to shut down the entire treated water system.

### Additional District Storage

The District currently operates 40 MG of potable water storage, which complies with the District's storage criteria, described in **Chapter 5**. To be completely independent during a planned 10-day outage in winter months, the District would require approximately 85 MG, increasing to 100 MG at projected buildout. The current deficit is approximately 45 MG, increasing to 60 MG at projected buildout.

The District owns approximately 16 acres of property along Buena Creek Drive, adjacent to the 20 MG Pechstein Reservoir site. The District purchased this property having anticipated additional District storage at this elevation may someday be necessary. **Figure 4-7** provides an aerial view of the site, and illustrates the availability of space within the property boundaries to locate three additional 20 MG tanks, which would fully address the projected 10-day emergency storage deficit of 60 MG. To prepare for a planned outage, the District would fill these tanks prior to the planned event, via the VID 3 connection.

At a planning level cost of \$1.50 per gallon, these additional tanks would require an investment of \$90 million. While advantageous during an aqueduct outage, day to day use of all three tanks could cause water age and quality issues. However, investment in one new 20 MG tank (Pechstein II) would partly mitigate the District's need for storage during annual aqueduct shutdowns by providing an additional 2 days of storage. This new tank would also provide complete redundancy for the existing Pechstein Reservoir, so that it could be taken out of service for operation and maintenance activities.

**Figure 4-7. Pechstein Reservoir Site Property Map**



#### Local Interagency Connections - Oceanside

In 2013, the District entered into an agreement with the City of Oceanside for the sale of water from the Weese WFP. The agreement allows the District to purchase up to 5 MGD from November 1 to April 30 and up to 2.5 MGD from May 1 through October 31, totaling up to 4,150 AFY. The current treatment cost is \$141.75/AF and is escalated on July 1 of each year by the consumer price index. The agreement is automatically renewed each year unless terminated by Oceanside or the District by giving 6 months advanced notice. Built in 1983, the plant is capable of treating up to 25 MGD and delivering that supply to the Water Authority's North County Distribution Pipeline. The North County Distribution Pipeline can be operated independent of treated water aqueduct Pipeline 4, as long as there is a supply of raw water to the Weese WFP. The District's VID 11 connection draws its supply from this pipeline. During winter months the Weese WFP has excess capacity.

In July 2017, the City of Oceanside presented a staff report to its Utilities Commission, proposing an amendment to the 2013 agreement that would allow the District to purchase up to 3.3 MGD from November 1 to April 30 and up to 5 MGD from May 1 through October 31, totaling up to 4,440 AFY. As Oceanside's expands its plans

for recycled water production and use, Oceanside Public Utilities staff noted that additional capacity at the Weese WFP may become available. Oceanside estimates that the cost of the treated water would be at least \$180 per AF. As delivery would be through the Water Authority's regional facilities, the District would be billed directly by the Water Authority for the cost of new water demand. Similar to the current agreement, this new agreement would be renewable on a year to year basis and can be cancelled by either agency with 6 months advanced notice.

This local supply would offset 33 MG (3.3 MGD x 10 days) of the estimated 60 MG of new storage needed for the District to be completely independent during a 10-day treated water aqueduct outage. Even if this supply were only used during the 10-day outage, this almost \$20,000 annual purchase ( $\$180 \text{ per AF} \times 33 \text{ MG} \times 3.07 \text{ AF/MG} = \$18,235$ ) would certainly be advantageous over the construction of 33 MG of new storage at \$1.50 per gallon or \$49.5 million.

In the event that the Vista Flume outage becomes long term, this alternative allows the District to transfer a portion of its purchase of raw water from the Water Authority that is currently sent to the EVWTP, but would be inaccessible if the Flume was out of service, to the Weese WFP. At a cost of \$180 per AF, the annual cost for 4,440 AFY of local water would be \$0.8 million per year. This cost may be offset if the District were to sell or lend its capacity at the EVWTP, which it would no longer be using; however, a long-term water purchase agreement with Oceanside would be required.

#### Local Interagency Connections – Vallecitos Water District

The VWD lies east and south of the District and share 10 emergency service connections with the District's system. Only one connection, V-3, is located such that it could serve the District at an equivalent elevation to the District's VID 3 connection to the Water Authority aqueduct. The V-3 connection allows flows up to 2,000 gpm or 2.88 MGD. As VWD has approximately 30 MGD of potentially excess storage capacity in its Twin Oaks Reservoirs, in the event of a planned 10-day outage of the aqueduct system it is possible that the District could negotiate access to that capacity, assuming VWD has the capability to deliver the water from the Twin Oaks Reservoirs to V-3.

This local emergency supply source would offset 28 MG (2.88 MGD x 10 days) of the estimated 60 MG of new storage needed by the District to be completely independent during 10-day treated water aqueduct outage. Similar to the Oceanside supply source, this opportunity is likely to be significantly less costly than constructing new storage facilities.

### 4.5.2 Opportunities to Provide Redundancy to Vista Irrigation District 3 Connection

With a long term outage of the Vista Flume, the VID 3 Connection is the sole connection to the Water Authority aqueduct that can directly feed the Pechstein Reservoir, which serves the 837/810 zones. VID 9 and VID 11 both feed this zone; however, because of the distance from Pechstein, a significant amount of pressure is required to account for the elevation difference and head loss that occurs when trying to deliver water to the Pechstein Reservoir.

Two alternatives were considered to serve Pechstein Reservoir from VID 9 or VID 11, if both the Flume and VID 3 were out of service. These alternatives are discussed in the paragraphs below.

### E Reservoir Expansion and New Pump Station

VID 11 serves the 837/810 zone, which in turn feeds the E Reservoir and the 752 zone. Although they serve different pressure zones, the E Reservoir is located in close proximity to the HP 5.0 MG Reservoir, which serves the 984/976 zone and has recently been rehabilitated. Shown in **Figure 4-8**, the E Reservoir is located on a 1.55 acre parcel adjacent to Edgehill Road. The 1.5 MG concrete tank is a below ground, oval in shape, 96 feet wide and 244 feet long. Built in 1929, the tank is scheduled for near term replacement. In 1995, the District conducted an initial environmental assessment for replacing the E Reservoir with a 146-foot diameter, 35 feet deep prestressed concrete reservoir with a capacity of 4.4 MG.

Replacement of the E Reservoir and the addition of a pump station feeding the higher zones (e.g., HP Reservoir) would provide a redundant means of getting 30 cfs of water from VID 11 to Pechstein Reservoir, in the event that VID 3 was out of service. This opportunity also provides a means of delivering any additional supply from the Weese WFP via VID 11 to the District's higher pressure zones. The hydraulic requirements and facilities needed to implement this opportunity are discussed in detail in **Chapter 8**.

**Figure 4-8. E Reservoir Property Map**



In the 1995 *Master Plan and Program Environmental Impact Report*, the 5 MG E Reservoir replacement project included raising the high water level of the tank by 25 feet to an overall height of 38 feet, with the west side of the tank being entirely above grade. Along the east side, 23 feet of the tank would be subterranean. The program environmental impact report noted the existence of sensitive habitat along the northwest corner of the site, potentially requiring mitigation. Based on the storage capacity evaluation conducted in **Chapter 7**, increasing storage in this location would be beneficial in serving the 752 zone, however the site has limited room for expansion and close neighbors such that raising the height of the reservoir may be challenging. The new site plan would also need to include space for a pump station.

## Delivery from Vista Irrigation District 11 and Vista Irrigation District 9 to Pechstein Reservoir

A hydraulic analysis was conducted to determine the capacity of the existing system to offset the VID 3 supply of 30 cfs to Pechstein through a balance of supply from VID 11 and VID 9. The goal of the iterative analysis was to maximize flow from VID 9 into the 837/810 zone with sufficient pressure to reach Pechstein, but without creating high pressures in the system and then allowing the balance of the 30 cfs flow to come from VID 11, again without creating high pressures in the system. The hydraulic requirements and facilities needed to implement this opportunity are discussed in detail in **Chapter 8**.

### 4.5.3 Recommended Opportunities for Further Study

It has been noted that complete rehabilitation of the Flume and the alternative of construction of 60 MG of new storage facilities are both quite costly, in excess of \$36 to \$75 million and \$90 million, respectively. This section identified a number of alternatives that, when combined, provide sufficient supply redundancy to offset the Flume being out of service either short term or long term.

The following opportunities for adding redundancy, reliability, and operational flexibility are recommended for further detailed study.

1. Continue to advocate for the installation of new isolation valves on the Second Aqueduct treated water system or other operational flexibility projects with the Water Authority.
2. Construct a new 20 MG storage tank at the Pechstein Reservoir site to provide 2 days additional storage and operational redundancy to the existing tank.
3. Enter into a long-term agreement with the City of Oceanside to gain access to excess treated water capacity at the Weese WFP for at least 3.3 MG during winter months and 5 MG during summer months.
4. Negotiate an agreement with VWD for access to excess storage capacity (up to 28 MG) during a 10-day Water Authority planned outage.
5. Maximize use of capacity within the existing system to allow supply from VID 11 and/or VID 9 to reach Pechstein Reservoir.

## 4.6 Recycled Water Coordination

The Shadowridge Water Reclamation Facility (WRF) was built in 1986 to provide wastewater treatment for the Shadowridge development and recycled water service for golf course irrigation. The facility was owned and operated by Buena Sanitation District. For failsafe capacity, the Buena Outfall was constructed. In August 1995, the District's Board of Directors approved a Water Reclamation Master Plan (WRMP), with a goal of reducing potable water demand by providing recycled water to certain targeted customers. The WRMP identified approximately 2,200 AF of recycled water demand that could be available for distribution within the District's service area on an annual basis. This plan required significant investments in treatment, storage and distribution infrastructure by the City of Vista and the Buena Sanitation District, and was never implemented.

In 2003, the Shadowridge WRF was decommissioned, as treatment capacity became available at Encina, and it was no longer financially feasible to operate the WRF. Currently, there is no recycled water being delivered to customers in the District's service area. A study prepared in August 2010 estimated that the capital cost to renovate/expand the mothballed Shadowridge WRF to 2.0 MGD and make the plant operational would cost approximately \$17.9 million.

In June 2010, the District joined with the Olivenhain Municipal Water District, Carlsbad Municipal Water District, VWD, Santa Fe Irrigation District, City of Oceanside, Leucadia Wastewater District, City of Escondido, Rincon Del Diablo Municipal Water District and the San Elijo Joint Powers Authority to form a coalition (the North San Diego Water Reuse Coalition) to investigate the expanded use of recycled water within north San Diego County. The Coalition has had an engineering report prepared that analyzed existing and proposed recycled water facilities and evaluated each of the participating agencies ability to interconnect and maximize the use of recycled water within their combined service areas.

The 2013 North County Regional Recycled Water Facilities Plan identified a potential recycled water demand of 1,840 AFY (including the Shadowridge Golf Course) and considered using the Shadowridge WRF failsafe outfall as a conduit for delivering recycled water from the City of Carlsbad to the District. The long term potential recycled water demand was estimated to be over 3,000 AFY. The facilities required included significant investment in pipeline facilities to reach the proposed recycled water customers, as shown in **Figure 4-9**.

**Figure 4-9. Proposed Regional Recycled Water Facilities**

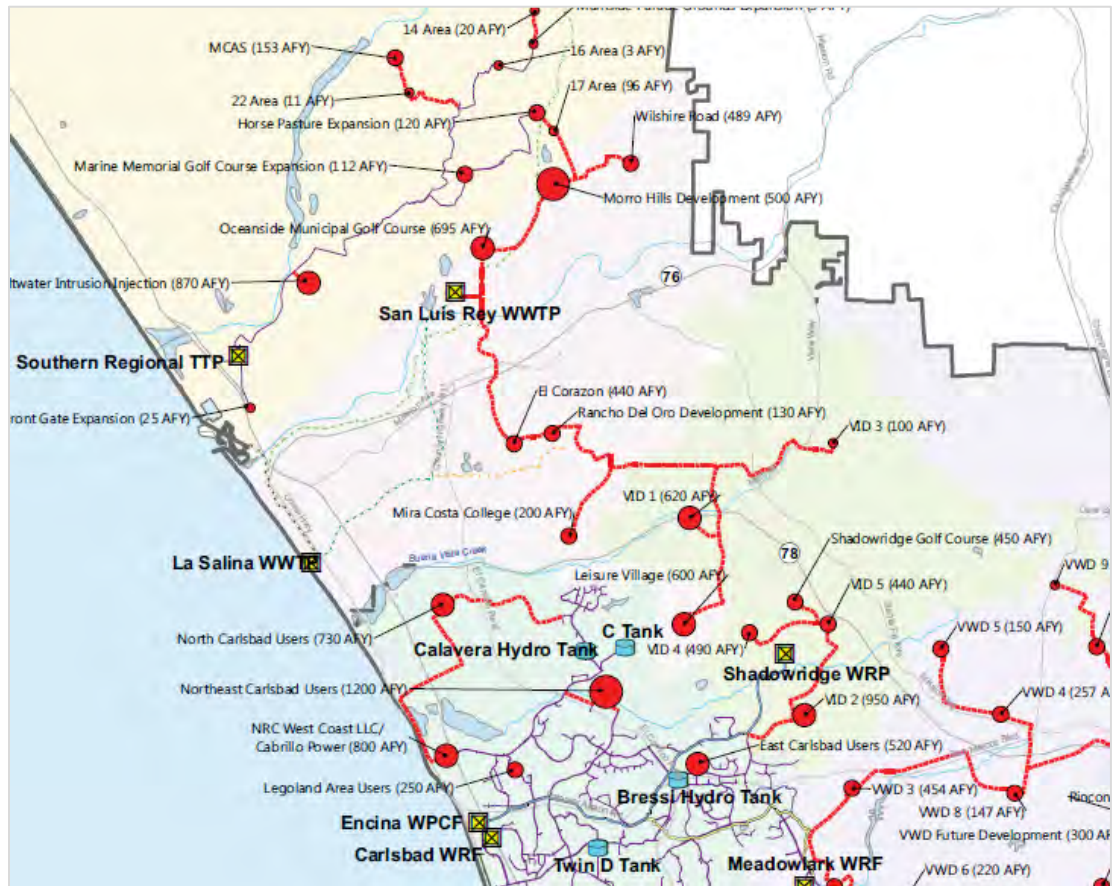

Source: 2013 North County Regional Recycled Water Facilities Plan

The option presented included extension of the recycled water distribution system from the Oceanside San Luis Rey Wastewater Treatment Plant to two potential groups of recycled water customers within the District: VID 3 (100 AFY) and VID 2 (620 AFY). A second pipe extension was proposed from the Carlsbad recycled water system to serve the Shadowridge Golf Course (450 AFY), VID 2 (950 AFY), VID 4 (490 AFY) and VID 5 (440 AFY). Based on a rough estimate of cost sharing, the District would be responsible for as much as 40 percent of the 10-mile Oceanside system extension, serving only 720 AFY, and 100 percent of the 8-mile Carlsbad system extension, serving 2,330 AFY.

Assuming these pipes were on average 10-inch diameter pipes, at a cost of \$325 (including engineering design costs and contingencies), that the District would pay their share of the pipeline extensions and pay their neighboring agencies for retail recycled water rates, and subsequently charge their customers the potable rate of water until the investment was paid off, the payback rate was estimated to range from 12 to 28 years. This return on investment calculation is provided in **Table 4-4**.

The return on investment to serve these same customers, who in 2016 are only using 10 percent of the amount of water they were in 2014, would be increased ten-fold.

In 2015, an alternative proposal was presented to the District Board to construct a recycled water pipeline from Oceanside's El Corazon WRP to the Ocean Hills Golf

Course, and possibly extending it to the Shadowridge Golf Course, as well as other potential irrigation customers along the Melrose Drive corridor. The Shadowridge Golf Course recently drilled a groundwater well on their property and removed turf in order to reduce its demand on potable water, which negatively impacted the economic feasibility of the project. The District subsequently agreed to allow transfer of Round 2 Proposition 84 construction grant funding for this proposed project to the City of Oceanside.

Given the significant drop in water use for the District's potable water customers that were being considered for conversion to recycled water, in addition to the Shadowridge Golf Course going to well water, the Board's decision appears to have been a prudent one.

**Table 4-4. North County Recycled Water Project Return on Investment**

Recycled Water Project	Cost Share to VID (%)	Length of Pipe (Miles)	Size of Pipe (Inches)	Unit Cost (\$/foot)	Total VID Cost (Millions)	Recycled Water Served (AF)	Unit Cost of Recycled Water (\$/Hundred Cubic Feet)	Unit Cost of Recycled Water (\$/AF)	VID Potable Water Cost (\$/AF)	Difference in Unit Cost (\$/AF)	Years Required to Recoup Pipeline Investment
Oceanside Recycled Water Pipe Extension	40	10	10	325	6.864	720	2.42	1,054	1,812	758	12.58
Carlsbad Recycled Water Pipe Extension	100	8	10	325	13.728	2,330	3.69	1,607	1,812	205	28.74

AF – acre feet; VID – Vista Irrigation District

## 5 Planning and Design Criteria

The District's planning and design criteria for potable water facilities are based on past criteria used by the District, criteria obtained from the 2000 Master Plan and current industry and area standards.

Planning and design criteria include standards for peaking factors, pressure, velocity, storage, and fire flow. These criteria are the basis for evaluating water system performance and determining facility requirements to serve future development.

**Table 5-1** displays the system design criteria summary for the Districts water facilities. The following sections expand on these criteria.

### 5.1 System Pressure Criteria

The range of water pressures experienced at any location is a function of hydraulic grade and the service elevation. Within a specific pressure zone the hydraulic grade is affected by the reservoir water level and/or pressure reducing valve setting and the headloss in the distribution system. The maximum desired pressure is 150 pounds per square inch (psi). This criteria limits pressures in the distribution system and deliveries to customers for operational and maintenance purposes.

The criteria for minimum desired pressure in residential areas is 40 psi under peak hour flow conditions and 20 psi at a fire flow location during a fire occurring under maximum day flow conditions. The minimum pressure in the distribution system must be 20 psi based on Health Department guidelines and the ability to provide adequate pressures for fire flows.

### 5.2 Pipeline Criteria

Criteria for pipeline sizing are based on keeping fluid velocities low to minimize wear on valves and scouring of interior coatings, and limiting headloss in the distribution system. Water distribution mains should supply peak flows at velocities below 8 feet per second (fps) and headloss within pipelines should not exceed 10 feet per 1,000 feet of pipe. During fire flow situations pipeline velocities should not exceed 16 fps.

Looping is highly desirable in a distribution system and long, dead-ended pipelines should be avoided where possible due to reliability and water quality concerns. Although 4-inch diameter is the minimum pipe size, new pipelines supplying a fire hydrant are recommended to be a minimum of 8-inches in diameter to provide the minimum required fire flow rate.

Hydraulic water system models use the Hazen-Williams equation to determine headloss in a pipeline for a given flow rate. The Hazen-Williams coefficient or "C" factor in the equation is a function of the diameter, material, and age of the conduit. If detailed information is not available, a global "C" factor of 130 should be used in hydraulic models for all pipelines.

**Table 5-1. System Planning and Design Criteria Summary**

Category	Planning and Design Criteria
Unit Demands	See <b>Chapter 3, Table 3-2</b>
Demand Peaking Factors	Minimum Day/AAD Ratio = 0.5 Maximum Day/AAD Ratio = 2.0 Peak Hour/AAD Ratio = 3.0 See <b>Figure 5-1</b>
System Pressure	40 psi - minimum desired pressure at peak flow 20 psi - minimum allowable pressure at peak flow 20 psi - minimum allowable pressure with MDD+FF 150 psi - maximum desired pressure
Velocity	8 fps - maximum velocity with peak hour flows 16 fps - maximum FF velocity
Headloss	10 feet per 1,000 feet maximum desired headloss at peak flow
Diameter	4-inch diameter minimum 8-inch diameter for new pipelines supplying a fire hydrant
Fire Flow	Rural Residential 1,000 gpm, 2-hour duration (2,500 gpm in High and Very High Fire Hazard Areas) Single Family Residential 1,500 gpm, 2-hour duration Multi-Family Residential 2,000 gpm, 2-hour duration Schools 2,500 gpm, 2.5-hour duration Commercial 3,000 gpm, 3-hour duration Industrial 3,500 gpm, 3.5-hour duration
Storage	Capacity equal to: 0.1 x MDD Operational Storage plus the greater of 2 x AAD Emergency Storage or Minimum Required FF x Minimum Required Duration Note: Emergency Storage may be located in a higher pressure zone if the stored water can be delivered by gravity.
Pump Station (Zones with Reservoirs)	MDD + 150 gpm Fire Storage replenishment Minimum Number of Pumps – Three (two duty + one standby) Pumping Period - During SDG&E off-peak and semi-peak rates is preferable Standby Power - Generator in building and in separate room
Hydropneumatic Pump Station (Zones without Reservoirs)	Peak Hour (or) MDD + FF, whichever is greater Minimum Number of Pumps - Four (one duty + one standby for domestic use plus one duty + one standby for FF) Pumping Period - 24 hours Standby Power - Generator in building and in separate room

AAD - average annual demand; FF – fire flow; fps – feet per second; gpm – gallons per minute; MDD - maximum day demand; MDD+FF – maximum day demand plus fire flow; PS – pump station; psi - pounds per square inch

### 5.3 Fire Flow Criteria

Water must be available not only for domestic use, but also for emergency fire fighting situations. This fire flow must be sustainable for a specific duration at a minimum

pressure of 20 psi. General standards establishing the amount of water for fire protection purposes are set by the Insurance Services Office (ISO), and these general standards are applied by local fire jurisdictions such as the City of Vista Fire Department. Based on discussions with the Vista Fire Department, the standards are specific to a particular building based on a number of considerations such as type of occupancy, type of construction and construction materials, distance from other structures, and additional factors. Those standards are available in the 2016 California Fire Code, Part 9, Appendix B Tables B105.1(1), B105.1(2), and B105.2, which are used by developers with specific building design projects. It should be noted that many of the older areas in the District were originally designed with less stringent requirements.

For planning purposes minimum fire flows and durations for general building categories, in conformance with the 2016 California Fire Code, are included in **Table 5-2**. The minimum fire flows for different land uses range from 1,000 gpm to 3,500 gpm.

**Table 5-2. Fire Flow Criteria**

Land Use	Minimum Required Fire Flow (gpm)	Minimum Required Duration (Hours)
Rural Residential	1,000	2
Single Family Residential	1,500	2
MultiFamily Residential	2,000	2
All Residential Areas in High and Very High Fire Hazard Areas	2,500	2
Schools	2,500	2.5
Commercial	3,000	3
Industrial	3,500	3.5

gpm – gallons per minute

The Vista Fire Protection District’s Ordinance 2013-23 requires higher fire flows for new subdivisions in wildland-urban interface areas. Wildland-urban interface areas are geographical areas identified by the state as "Fire Hazard Severity Zones." High and Very High Fire Hazard Severity Zones are located along the northern, eastern and southern boundaries of the District, as shown on **Figure 2-7**.

Ordinance 2012-23 states,

Section 507.2: "In setting the requirements for fire flow, the fire code official shall follow section 507.3 or Appendix B of the County Fire Code, or the standard published by the Insurance Services Office, "Guide for Determination of Required Fire Flow."

Section 507.3: "In wildland-urban interface fire areas, as defined in Appendix B, the main capacity for new subdivisions shall be not less than 2,500 gpm unless otherwise approved by the Fire Chief."

## 5.4 Storage Criteria

Storage of the District's potable water is provided by 12 reservoirs that serve specific pressure zone areas. Of the 12 reservoirs, 10 are located in the main service area, and 2 are in the Boot and Bennett area, east of the main service area. The reservoirs provide operational storage, emergency storage and fire flow storage. Operational storage refers to the peak hour fluctuations above MDD and is further discussed in **Section 5.4.1**. Emergency storage criteria in **Section 5.4.2** is developed to ensure water is available during a wide range of emergency events. Emergency storage might be necessary in the event of pipeline or reservoir failure, as well as planned and unplanned outages of water supply service. Significant outages of the Vista Flume and Water Authority Aqueducts are explored in **Section 4.4**. Fire flow storage requirements are discussed in **Section 5.4.3**.

### 5.4.1 Operational Storage

While the Water Authority Aqueduct connections and the Vista Flume generally supply a constant 24-hour flow rate, additional flows to supply peak demand periods must be satisfied by drawing on water stored in the District's reservoirs. Providing operational storage within a zone allows transmission mains for the pressure zone to be sized for maximum day, rather than higher peak hour flows.

For this Master Plan, the operational storage requirement is calculated in a similar manner to the 2000 Master Plan. Operational storage is equal to the volume of water used during the maximum day in excess of the 24-hour average for the maximum day.

**Figure 5-1** displays the calculated 24-hour MDD curve which is based on hourly demand data obtained during model calibration. The required operational storage (volume of demand above the maximum day peaking factor of 2) is equivalent to approximately 10 percent of the MDD or 20 percent of the AAD. This assumes that the available incoming water supply is equal to the MDD; otherwise more operational storage would be required.



Figure 5-1. Operational Storage Volume

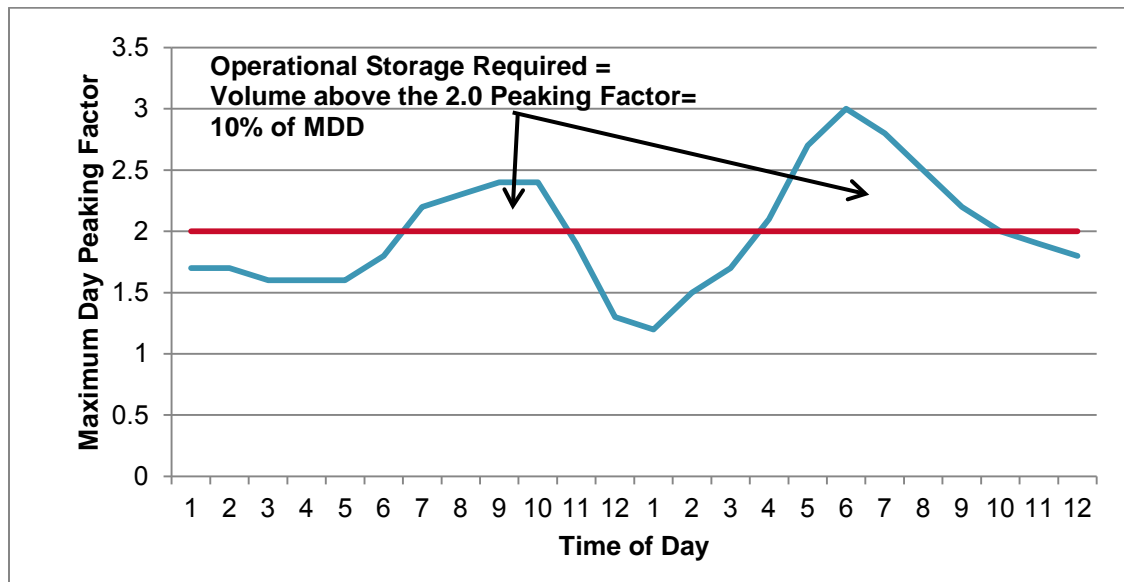

Operational storage criteria in other San Diego County water agencies range from 15 to 30 percent of MDD, indicating that their peak hour demand (PHD) may be higher than the District's, requiring additional storage.

#### 5.4.2 Emergency Storage

The District's emergency storage criterion is 2 days of AAD. By comparison, emergency storage criteria for other San Diego County water agencies range from 1 to 3 days of AAD. The amount of emergency treated water storage necessary is based on an assessment of the risk and the degree of system reliability desired. Since the District has partial ownership of the EVWTP, access to substantial raw water reserves, emergency interconnects to other water districts, and multiple Water Authority filtered water connections; it has more options during an emergency than many other water purveyors in San Diego County.

As discussed in **Section 4.4**, the Water Authority recommends that its member agencies maintain 10 days of storage or alternative supply in order to be self reliant during routine maintenance on the aqueducts. With the exception of emergencies, the maintenance typically occurs during winter months when demands are low. MinDDs are typically 50 percent of the AAD demand. As discussed in **Chapter 3**, the District's current AAD is approximately 17 MGD and projected buildout AAD is 20 MGD. Ten days of storage during minimum demand days would require the District to have 85 to 100 MG of storage capacity. The District currently has just over 40 MG of storage capacity.

To offset a planned outage of the Water Authority aqueducts, the District relies on its capacity rights for 18 MGD at the EVWTP, which can be conveyed to the District via the Vista Flume. Meeting a 10-day outage of the Water Authority aqueduct by depending on the District's local supply via the Vista Flume has been sufficient to meet the Water Authority independence criteria. Water supply reliability was further assessed in **Section 4.4**.

To address local emergencies, such as District main breaks or short term power outages, storage should be provided by reservoirs located in the same pressure zone or at a higher elevation. This will ensure that each zone could still receive water when pumped water is unavailable and stored water can be delivered by gravity. In the 2000 Master Plan, it was determined that having approximately 50 percent of the District's MDD in the 837 zone, where the District's largest reservoir, the 20 MG Pechstein Reservoir, is located, was acceptable since this water is available by gravity to the District's main service area. Similar to the District, the City of Escondido also allows for emergency storage to be located at upper zones when water can be fed by gravity to lower zones in an emergency.

Water quality regulations are becoming more stringent, and system operators are finding it more difficult to maintain the water quality in reservoirs, especially in those that do not have good turnover rates. In special circumstances, the District may elect to reduce or eliminate the emergency storage component for a specific zone if there are multiple supply sources, delivery locations and a well-looped transmission system within the zone. This option was added to the storage criteria in this master plan update to address potential water quality concerns and the lack of suitable storage sites, and to allow for alternative improvements to bring in new sources of water in lieu of constructing additional storage.

### 5.4.3 Fire Flow Storage

Fire flow storage is established to ensure that each reservoir serving the District is able to supply enough water to extinguish the worst case fire that is likely to occur within its service area. Each reservoir should contain adequate fire flow storage for a single fire based on the most intensive fire flow demand in that pressure zone, or service area if the reservoir serves more than one pressure zone. Fire flow criteria, shown in **Table 5-2**, range from 1,000 gpm for 2 hours, requiring 120,000 gallons in storage, to 3,500 gpm for 3.5 hours, requiring 750,000 gallons in storage.

**Figure 2-7** displays the very high, high, and moderate fire hazard severity zones within the District's service area. Since the previous District master planning effort, California Department of Forestry and Fire Protection has designated significant parts of the District to be within Fire Severity Zones, requiring increased fire flows and emergency storage to fight potential wildfires. These areas require 2,500 gpm for 2 hours or 300,000 gallons of storage.

If the fire flow storage requirement is greater than the emergency storage requirement, then the fire flow volume should be used to determine emergency storage capacity requirements.

## 5.5 Pump Station Criteria

Pump stations boost the water pressure so that service may be provided to users at a higher elevation. Pump stations may supply water to an "open system" or to a "closed system." An open system is a service area with its own storage reservoir. A closed system is an area without a storage reservoir. Pump stations supplying a closed system must regulate pressures utilizing multiple pumps, variable speed drives, and/or a hydropneumatic tank.

Design criteria for pump stations supplying an open system require the pumps to provide capacity equal to the MDD plus an amount adequate to replenish fire storage in a reasonable period, usually 150 gpm. This replenishment is called recharge. The minimum number of pumps is three (two duty and one standby).

Design criteria for pump stations supplying water to a closed system require the pumps to provide capacity for either PHD or MDD plus fire flow (MDD + FF), whichever is greater. The minimum number of pumps is four (one duty, one standby for domestic demand, one duty, and one standby for fire flows).

If the pump station is for back up supply, or tank out of service scenarios, the pump station may need to be sized for peak or fire flows, on a case by case basis.

The District's distribution system is essentially supplied by gravity, and the existing pump stations are operated periodically to maximize supply from the Vista Flume, circulate water in the Pechstein Reservoir, or to compensate for "unbalanced" supplies from the Water Authority connections. The pump stations also increase system reliability by providing a redundant supply. To reduce electricity costs, pumping during SDG&E off-peak and semi-peak rates is preferable. Back up generators in a building and in separate room are recommended.

## 5.6 Pressure Regulating Station Criteria

A pressure regulating/reducing station (PRS) is used to convey water from a higher pressure zone to a lower pressure zone and maintains a desired downstream grade. A pressure sustaining feature can be incorporated to ensure that the pressure upstream does not drop below a desired pressure. A valve with both of these features is called a combination pressure reducing/sustaining valve, or combination PRS. The District has 17 of these combination PRSs that switch between the two modes throughout the day. Combination PRSs can make system operations challenging but are necessary to control flow rates from higher to lower zones to prevent "robbing" supply from the upper zone. Generally, supply to a zone remote from a reservoir should operate primarily in the pressure reducing mode, while supply near a reservoir may be controlled on reservoir water levels and would operate in the sustaining mode while a reservoir is filling. To ensure system reliability, there should be at least two PRSs supplying each major zone.



*This page is intentionally blank.*

## 6 Existing System

This chapter presents a summary of the District's existing water distribution system, including an overview of the major facilities and a description of system operations on a zone by zone basis.

### 6.1 Distribution System Facilities Overview

The District currently provides service to three separate service areas including the primary Vista service area and two smaller service areas to the east, respectively referred to as the Boot and Bennett service areas. The majority of the District's customers, infrastructure, and demands are located in the primary Vista service area. A map of the District's existing distribution system major facilities and pressure zones is provided in **Figure 6-1**.

The District currently operates the Vista service area distribution system as 14 distinguishable pressure zones. A water system schematic of the District's distribution system, illustrating how these zones are connected is provided in **Figure 6-2**.

Pressure zones in the primary service area are supplied from:

- Water Authority Second Aqueduct connections (707, 810, 837, and 976/984 zones) (The locations of these connections are shown on **Figure 4-6**.)
- EVWTP via the Vista Flume (837 zone)
- PRSs (486, 550, 565, 630, 637, 668, 707, 752, 900 and 976/984 zones)
- Pump stations (976/984 and 1070 zones)
- VWD Metered Connection (1360)

Flows from the Vista Flume are delivered directly to Pechstein Reservoir or conveyed to the 976/984 zone by pump station. Nine of the 14 zones in the primary Vista service area contain their own reservoir storage (550, 565, 637, 707, 752, 810/837, and 976/984 zones). The 837/810 zones operate as a single zone, as does the 976/984 zones. The five zones in the primary Vista service area that do not contain storage (486, 630, 668, 900, and 1070 zones) are smaller service areas that are supplied via pump stations or PRSs.

The Boot and Bennett service areas are supplied from District's connection to the Water Authority's First Aqueduct and the EVWTP via the Vista Flume. The Boot service area is split into two pressure zones (850, 870). The Bennett service area is also split into two pressure zones (898, 980). The 898 zone is served by two reservoirs. Local pump stations convey flow to the 980 zone.



*This page is intentionally blank.*

Figure 6-1. Major Facilities and Pressure Zones

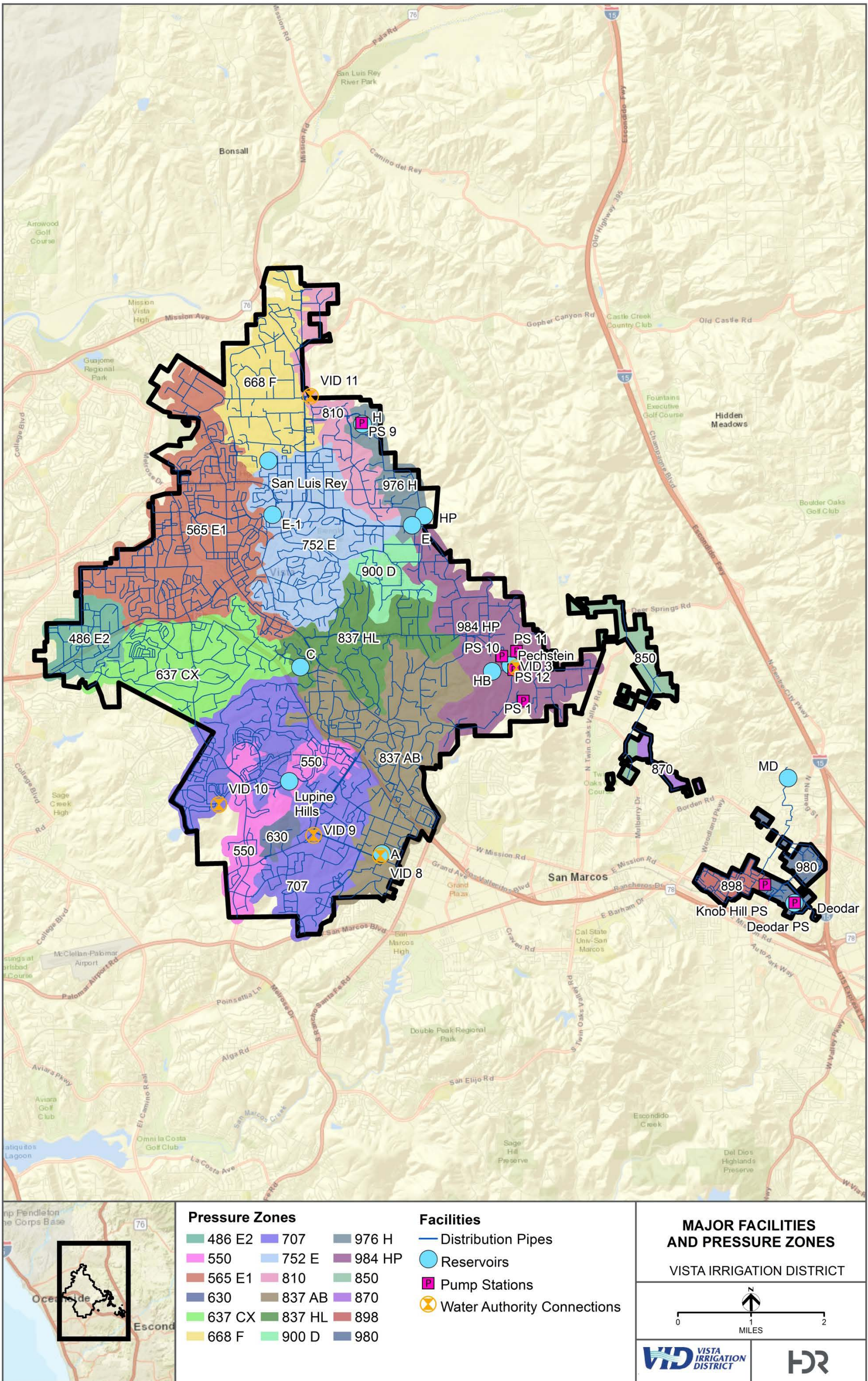

PATH: C:\USERS\JENGLESO\DOCUMENTS\DOCUMENTS\PROJECTS\VISTA\_IRRIGATION\_DISTRICT\2016\_WATER\_MASTER\_PLAN\_UPDATE\_10043046\INFOWATER\VID\_EXISTING\_SYSTEM\_PRESSURE\_ZONES.MXD - USER: JENGLESO - DATE: 1/16/2018



*This page is intentionally blank.*

Figure 6-2. Existing System Hydraulic Schematic

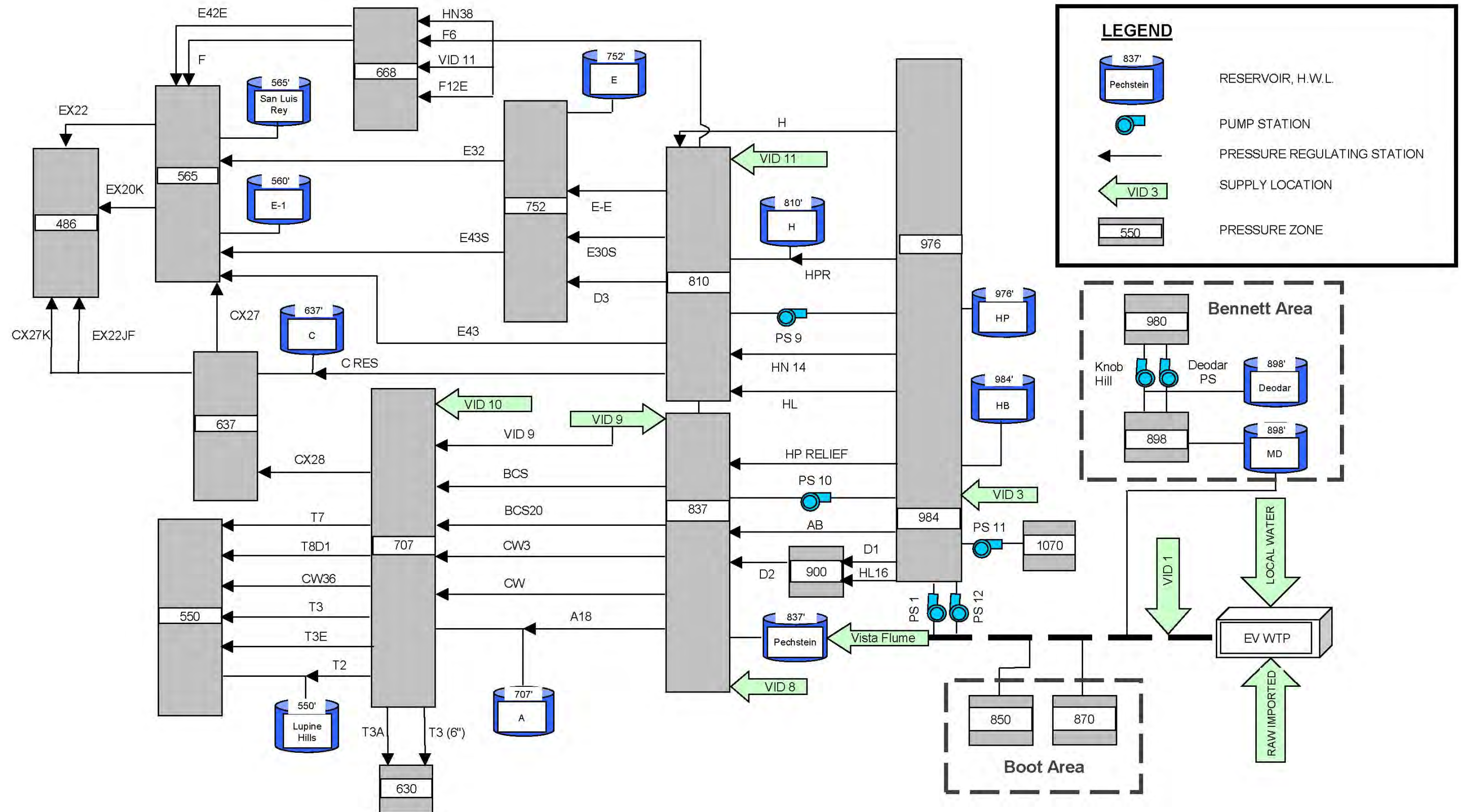

Source: Vista Irrigation District 2017

*This page is intentionally blank.*

## 6.2 Pipelines

The District’s transmission and distribution network includes over 429 miles of pipelines, owned and maintained by the District, and 10 miles of privately-owned, District-maintained properties. The materials, size or capacity and lengths are listed in **Table 6-1** and **Table 6-2**. **Appendix C** includes a large scale map showing pipe material and diameter and a similar map showing pipe age.

In 1995, the Board of Directors initiated an on-going Main Replacement Program with the goal of replacing aging pipelines before they reach the end of their useful life and become a maintenance liability. The Main Replacement Program allows pipe replacements to be prioritized based on the age of the line, leak history, and pipe material, as well as a number of factors related to site conditions. Since its inception, 28 miles of older pipe ranging in size from 4 to 20 inches have been replaced.

As part of this Master Plan, the current system performance and deterioration rates were analyzed and recommendations for improvements to the current prioritization process were developed. Those findings are summarized in **Section 6.7**.

**Table 6-1. Distribution Pipeline Inventory**

Pipeline Material	Size Range (Inches)	Length of Pipe (Miles)
Asbestos Concrete	4 to 12	250
Asbestos Concrete	14 to 36	17
Polyvinyl Chloride	4 to 12	91
Polyvinyl Chloride	14 to 24	3
Steel	4 to 12	38
Steel	14 to 36	24
All other Materials	>4	6
<b>Total</b>		<b>429</b>

**Table 6-2. Transmission Pipeline Inventory**

Transmission Facility	Carrying Capacity (cfs)	Length of Pipe (Miles)
Escondido Canal and Intake	70 (District has rights to 2/3 of capacity)	14
Vista Main Canal (Flume)	33 (based on 2017 assessment of Baumgartner Siphon carrying capacity)	12

cfs - cubic feet per second

## 6.3 Reservoirs

Reservoir storage for the primary Vista service area is provided by the 20 MG Pechstein Reservoir and nine additional reservoirs, ranging in size from 0.7 to 5.4 MG. The Bennett service area is served by two reservoirs, the MD and Deodar Reservoirs.

**Table 6-3** summarizes the capacity, elevations, and dimensions of the District's reservoirs.

Condition assessment of the District's reservoirs was conducted in November 2016 as part of this Master Plan update effort. Those findings are summarized in **Section 6.7.2. Two of the 12 reservoirs were not inspected.**

In late 2016, the HP Reservoir was out of service while it was undergoing retrofits. The HP Reservoir is a 4.5 MG pre-stressed concrete reservoir constructed in 1962. The rehabilitation improvements included replacement of pre-stressing wires, seismic retrofit, new roof, aluminum dome roof and interior/exterior staircases, and inlet/outlet piping upgrades.

The E Reservoir is currently scheduled for near term replacement and, therefore, was also not inspected.

**Table 6-3. Storage Reservoir Summary**

Reservoir Name	Pressure Zone	Operating Capacity (MG)	Actual Capacity (MG)	Bottom Elevation (Feet)	HWL Elevation (Feet)	Interior Dimensions (Feet)	Construction Year	Reservoir Type			Reservoir Roof Type
								Buried/ Above Ground	Shape	Material	
Lupine Hills	550	3.00	3.40	537	568	137	1987	Partially Buried	Circular	Prestressed Concrete	Reinforced Concrete
A	707	0.60	0.80	695	708	100	1926	Partially Buried	Circular	Cast-in-place Reinforced Concrete	Wood Rafter and Girder System
Pechstein	837	18.50	20.00	810	837	355	1978	Partially Buried	Circular	Prestressed Concrete	Wood Rafter and Girder System
HB	984	4.05	4.50	951	981	160	1964	Above Ground	Circular	Prestressed Concrete	Tapered Reinforced Concrete Dome
HP (Upon Rehabilitation)	976 (4.3)	4.05 (4.7)	4.50	945	975	160	1962	Above Ground	Circular	Prestressed Concrete	Tapered Reinforced Concrete Dome (Aluminum)
C	637	0.60	0.80	625	638	100	1926	Above Ground	Circular	Cast-in-place Reinforced Concrete	Wood Rafter and Girder System
E	752	1.20	1.50	741	753	96 x 244	1929	Buried	Oval	-	-
E1	565	0.50	0.60	547	560	90	1925	Above Ground	Circular	Cast-in-place Reinforced Concrete	Wood Rafter and Girder System
San Luis Rey	565	2.70	3.10	540	565	156 x 136	1978	Buried	Rectangular	Cast-in-place Reinforced Concrete	Reinforced Concrete
H	810	5.00	5.40	774	810	160	1997	Partially Buried	Circular	Prestressed Concrete	Reinforced Concrete
MD	898	0.19	0.20	886	900	55	1926	Partially Buried	Circular	Cast-in-place Reinforced Concrete	Wood Rafter and Girder System
Deodar	898	1.10	1.30	869	899	86	1978	Partially Buried	Circular	Prestressed Concrete	Wood Rafter and Girder System

Source: Vista Irrigation District (District) Water Supply Permit, February 2016  
MG – million gallons

*This page is intentionally blank.*

## 6.4 Pressure Regulating Stations

The majority of the primary Vista distribution system is supplied by gravity and supported either directly and/or indirectly via PRSs. Each of the pressure zones receives supply from two to six separate reducing and/or sustaining PRSs. Eleven PRSs are controlled remotely by SCADA. Information for the manually controlled PRSs, including existing control settings is summarized in **Table 6-4**. Information for the SCADA controlled PRSs is summarized in **Table 6-5**.

**Table 6-4. Manually Controlled Pressure Regulating Station Summary**

Pressure Regulator (ID and Diameter [Inches])		Location	Pressure Zone (Source/Control)	Set Point (psi)		Elevation (Feet)
				Sustaining	Reducing	
A18	6	770 Virginia Place	837 / 707	34/58	10	690
AB	12	2107 Esplendido Avenue	984 / 837	86	26	750
BCS20	3	921 Grand Avenue	837 / 707	118	80	505
BCS20	8	921 Grand Avenue	837 / 707	118	78	505
CW	3	1932 Watson Way	837 / 707	145	113	445
CW	8	1932 Watson Way	837 / 707	145	110	445
CW3	3	358 Mar Vista Drive	837 / 707	90	63	565
CW3	10	358 Mar Vista Drive	837 / 707	90	61	565
CW36	8	Sycamore and Thibido	707 / 550	125	65	390
CX27K	3	Hacienda Drive and Evelyn Lanen	637 / 486	NA	88	280
CX27K	8	Hacienda Drive and Evelyn Lane	637 / 486	NA	86	280
D1	4	2450 San Clemente Avenue	976 / 900	NA	90	695
D1	10	2450 San Clemente Avenue	976 / 900	NA	87	695
D2	6	1783 Sunrise Drive	900 / 837	128	86 / 98	620
D3	8	1946 Alta Vista Drive	837 / 752	NA	83	555
EX22JF	6	Cottonwood Drive	637 / 486	130	78	285
E42E	6	W. Knapp and W. Bobier Drive	668 / 565	72	45	450
E43	8	1034 South Santa Fe Avenue	837 / 565	NA	73	380
E43S	6	239 Terrace Way	752 / 565	135	55	410

**Table 6-4. Manually Controlled Pressure Regulating Station Summary**

Pressure Regulator (ID and Diameter [Inches])		Location	Pressure Zone (Source/Control)	Set Point (psi)		Elevation (Feet)
				Sustaining	Reducing	
EX20K	8	1331 West Vista Way	565 / 486	107	86	280
EX22	6	705 Emerald Drive	565 / 486	80	45	355
F	6	402 Osborne Street	668 / 565	125	84	350
F6	6	2728 East Vista Way	810 / 668	NA	40	550
F12E	8	Lower Taylor Street	810 / 668	135	78	465
F-Reg at VID 11	12	E. Vista Way and Osborne	810 / 668	NA	65	488
H-Reg at VID 11	8	E. Vista Way and Osborne	810 / 837	NA	130	488
H	10	1910 Camino Loma Verde	976 / 810	NA	68	625
HL16	6	2305 Catalina Avenue	976 / 900	NA	78	795
HN	3	Vista Grande Drive	837 / 810	NA	62	680
HN	8	Vista Grande Drive	837 / 810	NA	60	680
HN-14	3	1755 Kings Road	976 / 837	NA	62	670
HN-14	8	1755 Kings Road	976 / 837	NA	60	670
HN38	3	304581/2 Monratchet Street	810 / 668	125	82	440
HN38	8	304581/2 Monratchet Street	810 / 668	125	78	440
T3	6	Sycamore Avenue	707 / 630	NA	78	455
T3	12	Sycamore Avenue	707 / 550	NA	40	455
T3A	4	Business Park Drive	707 / 630	NA	84	440
T3A	8	Business Park Drive	707 / 630	NA	82	440
T3E	4	Park Center Drive	707 / 550	NA	52	460
T3E	8	Park Center Drive	707 / 550	NA	50	460
T7	3	1940 Live Oak Road	707 / 550	105	43	440
T7	6	1940 Live Oak Road	707 / 550	103	41	440
T8D1	6	1051 Chaparral Drive	707 / 550	132	65	400

psi - pounds per square inch



**Table 6-5. SCADA Controlled Pressure Regulating Station Summary**

Pressure Regulator (ID and Diameter [Inches])		Location	Pressure Zone (Source/Control)	Predominant Control Mode	Set Point (psi)				Elevation (Feet)
					Operator <sup>1</sup>		Control <sup>2</sup>		
					Sustaining	Reducing	Sustaining	Reducing	
BCS	6	400 3/4 Sycamore Avenue	837 / 707	Pressure	150	127	150	130	415
BCS	10	400 3/4 Sycamore Avenue	837 / 707	Pressure	150	120	150	130	415
CX27	6	Melrose and W. Vista Way	637 / 565	Flow	136	110	130	124	300
CX27	10	Melrose and W. Vista Way	637 / 565	Pressure	135	98	130	124	300
CX28	6	1099 S. Melrose Drive	707 / 637	Flow	148	122	138	125	330
CX28	10	1099 S. Melrose Drive	707 / 637	Pressure	151	98	138	125	330
C (Res.)	6	1301 Summit Terrace	837 / 637	Level / Flow	71	5	74	5	625
C (Res.)	10	1301 Summit Terrace	837 / 637	Level / Flow	74	5	72	5	625
E30S	6	1070A Taylor Street	810 / 752	Level / Flow	115	103	110	104	520
E30S	16	1070A Taylor Street	810 / 752	Level / Flow	113	102	112	104	520
E32	8	761 East Bobier Drive	752 / 565	Level / Flow	N/A	38	103	42	465
E32	12	761 East Bobier Drive	752 / 565	Level / Flow	N/A	40	103	42	465
E-E	8	2330 Edgehill Road	837 and 810 / 752	Pressure	N/A	5	20	8	740
HP-HL	12	2330 Edgehill Road	976 / 837	Pressure	N/A	26	80	42	740
HPR	12	2082 Pleasant Heights Drive	976 / 810	Level / Flow	N/A	N/A	74	11	775
HP-Rel.	10	3733 Bluebird Canyon Road	984 / 837	Relief	65	N/A	65	N/A	835

**Table 6-5. SCADA Controlled Pressure Regulating Station Summary**

Pressure Regulator (ID and Diameter [Inches])		Location	Pressure Zone (Source/Control)	Predominant Control Mode	Set Point (psi)				Elevation (Feet)
					Operator <sup>1</sup>		Control <sup>2</sup>		
					Sustaining	Reducing	Sustaining	Reducing	
HP-Rel.	16	3733 Bluebird Canyon Road	984 / 837	Relief	67	N/A	67	N/A	835
T2	6	2450 Lupine Hills Drive	707 / 550	Level / Flow	N/A	3	73	22	536
T2	12	2450 Lupine Hills Drive	707 / 550	Level / Flow	N/A	3	70	22	536

<sup>1</sup> Operator set-points are common set-points that can be routinely adjusted.

<sup>2</sup> Control set-points are limit points for the valve.

cfs - cubic feet per second; psi - pounds per square inch

## 6.5 Pump Stations

The primary Vista service area includes five pump stations which either convey flows to higher pressure zones within the service area or convey flows from the Vista Flume to the 976/984 zone. Three of the five pump stations convey flow from lower pressure zones to higher pressure zones including Pump Station (PS) 9 (from 810 to 976/984), PS 10 (from 837 to 976/984), and PS 11 (from 976/984 to 1070). Additionally, two pump stations convey flow from the Vista Flume to the 976/984 zone including PS 1 and PS 12. Depending on the volume of flow being conveyed by either the Vista Flume or the Water Authority connections, the five pump stations in the Vista service area can be used to distribute required flows to the service area’s four highest zones (900, 976/984, and 1070). In addition to the Vista service area, the Bennett service area is served by two pump stations, Knob Hill and Deodar, which can be used to convey flow from the 898 zone to the 980 zone. A summary of pump station data is provided in **Table 6-6**.

**Table 6-6. Pump Station Summary**

PS Name	Location	Year Constructed	Zones Served	Pump Capacity
PS 1	1852 Robinhood Road	-	Flume to 984	One pump at 550 gpm
PS 9	2082 Pleasant Heights	-	810 to 976	Two pumps at 1,500 gpm each
PS 10	3733 Bluebird Canyon	-	837 to 984	One pump at 1,300 gpm One pump at 1,600 gpm
PS 11	-	-	984 to 1070	Two pumps at 200 gpm each
PS 12	3874 Bluebird Canyon	-	Flume to 984	Three pumps at 1,600 gpm each
Knob Hill PS (PS 3)	1833 Knob Hill Road	-	898 to 980	One pump at 300 gpm Two pumps at 600 gpm each
Deodor PS (PS 4)	969 Deodor Road	-	898 to 980	Four pumps at 300 gpm each

gpm - gallons per minute; PS – pump station

## 6.6 Pressure Zones

The primary Vista service area distribution system is comprised of 14 distinguishable pressure zones as displayed in **Figure 6-1** and shown schematically in **Figure 6-2**. The Boot and Bennett service areas include two pressure zones each.

The high number of pressure zones in the primary distribution system is due to the topography of the service area, which generally slopes downhill from east to west. Currently, water is supplied at connection points in the eastern portion of this distribution

system to high elevation pressure zones. As the system is currently operated, water from these high elevation pressure zones flows downgradient through a series of PRSs to serve lower elevation zones. The District operations staff is responsible for maintaining the balance of pressure in the higher pressure zones while allowing flow to lower zones via the PRSs.

Conceptually, the primary Vista service area is divided into pressure zones in order to maintain acceptable pressures for customers. A hydraulic grade and AAD summary for each of the major pressure zones is shown in **Table 6-7**. The recommended low service elevation for a zone is calculated by subtracting 350 feet from the hydraulic grade of the zone. Any elevation lower than this would result in static pressures greater than 150 psi. The high service elevation for a zone can only be approximated because the actual minimum residual pressures are a function of elevation and headloss in the distribution system during peak demands.

**Table 6-7. Major Pressure Zone Demand Summary**

Pressure Zone/ Hydraulic Grade (Feet)	Hydraulic Grade Control <sup>1</sup>	AAD <sup>2</sup>		
		(AFY)	(gpm)	(MGD)
486	PRS	847	525	0.76
550	Lupine Hills Reservoir	1,497	928	1.34
565	San Luis Rey and E1 Reservoirs	3,704	2,296	3.31
630	PRS	60	37	0.05
637	C Reservoir	1,470	911	1.31
668	PRS	872	541	0.78
707	A Reservoir	3,001	1,861	2.68
752	E Reservoir	2,361	1,464	2.11
810	H Reservoir	536	332	0.48
837	Pechstein Reservoir	2,816	1,746	2.51
900	PRS	254	157	0.23
976/984	HP Reservoir	269	167	0.24
	HB Reservoir	996	617	0.89
Totals <sup>2</sup>		18,683	11,582	16.68

<sup>1</sup> Zones with reservoir hydraulic grade control typically represent tank high water level. The exception is Lupine Hills Reservoir, which has a high water level of 568 feet.

<sup>2</sup> Demands do not include the Boot and Bennett service areas.

AFY - acre feet per year; gpm – gallons per minute; MGD - million gallons per day; PRS – pressure regulating station

Major features and existing system operations of each pressure zone are described in detail below. The information is based on previous master plans and studies, site visits, and numerous discussions with field personnel.

### 6.6.1 984 and 976 Zones

The 984 and 976 zones operate as a single pressure zone, and the actual hydraulic grade depends on the service areas of the HB and HP reservoirs. This zone is supplied primarily by a combination of Water Authority water at VID 3 and water from the Vista Flume via PS 1 and PS 12. PS 10 is able to supplement the 984 zone from the 837 zone. The 4.5 MG HB Reservoir provides storage for the 984 zone.

The 984 zone borders several zones including 837, 900 and 1070. The AB PRS provides a connection from the 984 zone to the 837 zone. The HP Relief PRS connects 984 to 837 but is only used in bypass or relief mode. The 900 zone is served from PRSs D1 and HL16. Additionally, water is conveyed from the 984 zone to the 1070 zone via PS 11.

The 4.5 MG HP Reservoir is supplied from the 984 zone and provides storage for the 976 zone. PS 9 provides a backup supply from the 810 zone. There are four connections to the 810 zone via PRSs including H, HPR, HN14, and HL.

### 6.6.2 1070 Zone

The 1070 zone is a small pressure zone which serves five customers. This zone receives water from the 976/984 zone via PS 11.

### 6.6.3 900 Zone

The 900 zone is a smaller zone which receives water from the 976/984 zone via the D1 and HL16 PRSs. This zone also feeds the 837 zone via the D2 PRS.

### 6.6.4 810 and 837 Zones

The 810 and 837 zones are operated as a single pressure zone or as separate pressure zones at the District's discretion. The zones are separated by a valve that can be closed to isolate the two systems. Combined, the 810 and 837 zone is the largest zone spatially, extending from the San Luis Rey River at the northern boundary of the District all the way to the southern boundary of the District, south of Highway 78. If the 810/ 837 interconnecting valve is open, headloss through the distribution system is sufficient to qualify 810 and 837 as separate pressure zones, although they are not hydraulically separated by a pressure reducing facility.

The actual grade of the combination 810 and 837 zone varies between approximately 810 in the north and south and 837 in the vicinity of Pechstein Reservoir. The service area of the H Reservoir is often referred to as the 810 zone, although hydraulically is a part of the combination 810/ 837 zone. Due to headloss through the distribution system, the northern part of this zone is referred to as the 810 zone. The H Reservoir in the north has an operational high water grade of 806, instead of 837.

The 837 zone contains the largest storage volume, with 20 MG at Pechstein Reservoir. The primary supply to the 837 zone is the EVWTP via the Vista Flume. The

VID 1 connection to the Water Authority's First Aqueduct is another supply to the District via the Vista Flume, which terminates at Pechstein Reservoir. VID 8 and VID 9 are other Water Authority connections that serve the southern part of the 837 zone from the Tri-Agency Pipeline. PRSs that supply the 837 zone include HL from the 976/984 zone, D2 from the 900 zone, and HP Relief and AB from the 976/984 zone.

Along with gravity flow from the Pechstein Reservoir, the Water Authority supplies the 810 zone via the VID 11 connection. The 5.4 MG H Reservoir provides additional storage for the 810 zone. PRSs that supply the 810 zone include H, HPR, HL, and HN14 from the 976/984 zone.

Given the north to south spatial coverage of the combined 810 and 837 zones, as well as its large storage capacity, number of aqueduct connections, and high zone elevation, it follows that this zone has the largest number of PRSs of any other zone. These PRSs facilitate the supply to the lower zones. There are three PRSs to the 668 zone (F6, HN38, and F12E), three to the 752 zone (E30S, E-E, and D3), one to the 565 zone (E43), one to the 637 zone (C RES), and five to the 707 zone (CW3, CW, BCS, BCS20, and A18), for a total of 13 PRSs.

### 6.6.5 752 Zone

The 752 zone is in the central portion of the District, and is bordered by five other zones. The E Reservoir provides 1.5 MG of storage for the zone. Three PRSs supply the 752 zone from the 810/ 837 zone including E-E, D3, and E30S. There are two PRSs that feed the 565 zone from the 752 zone including E32 and E43S. The E32 PRS is the primary supply to the 565 zone, and the water level of E Reservoir is affected by the operation of the E32 PRS. The E32 PRS has four flow control settings, which are routinely changed by SCADA.

### 6.6.6 707 Zone

The 0.8 MG A Reservoir provides operational storage for the 707 zone. The primary supply to the zone is from Water Authority connections VID 9 and VID 10, off the Tri-Agency Pipeline. There are five PRSs from the 810/ 837 zone that supply the 707 zone: CW3, CW, BCS, BCS20, and A18, all of which have combination pressure sustaining/reducing controls. Nine PRSs supply lower zones from the 707 zone.

Two PRSs, T3 and T3A, serve the small, reduced 630 zone. The T3 PRS consists of two valves with one serving the 630 zone and the other serving the 550 zone. Six PRSs - T2, T8D1, CW36, T7, T3E, and T3 – feed the 550 zone.

The CX28 PRS supplies the 637 zone. This PRS is hydraulically critical in the event that the 707 zone becomes over pressurized by aqueduct turnout flows, which must be delivered at a constant flow throughout the day. If the 707 and 550 zones cannot utilize the flow ordered at VID 9 and 10, and the CX28 valve is closed, the flow at the turnouts will be rejected. Thus, the CX28 PRS is utilized to relieve excess flow to the 637 zone.

### 6.6.7 630 Zone

As discussed in **Section 6.6.6**, the 630 zone is a small, reduced zone supplied by the 707 zone via two PRSs, T3 and T3A. The T3 includes two valves, with one valve serving

the 550 zone and the second valve, a 6-inch pressure reducing valve, serving the 630 zone. T3A consists of two pressure reducing valves, including a 4-inch and an 8-inch, which serve the 630 zone from the 707 zone.

### 6.6.8 668 Zone

The 668 zone is in the north end of the District and is supplied from the 810/ 837 zone via three PRSs including F6, HN38, F12E. An additional 12-inch PRS is able to supply the zone from the VID 11 Water Authority connection. Two PRSs – E42E and F – deliver water from the 668 zone to the 565 zone.

### 6.6.9 637 Zone

The 637 zone is supplied from two PRSs, CX28 from the 707 zone and the C RES PRS from the 837 zone. The 0.8 MG C Reservoir provides operational storage for the zone. Three PRSs convey water from the 637 zone to lower zones: CX27 to the 565 zone and CX27K and EX22JF to the 486 zone.

### 6.6.10 565 Zone

The 565 zone has the highest demands in the District. Two reservoirs serve the zone, the 0.6 MG E-1 Reservoir and the 3.1 MG San Luis Rey Reservoir. There are five PRSs that feed the zone from four higher zones including F and E24E from the 668 zone, E32 and E43S from the 752 zone, E43 from the 837 zone, and CX27 from the 637 zone. There are two PRSs that supply the lower 486 zone: EX20K and EX22.

### 6.6.11 550 Zone

The 550 zone is supplied exclusively from the 707 zone through six PRSs: T2, T8DI, CW36, T7, TSE, and T3. Storage is provided by the 3.4 MG Lupine Hills Reservoir. The reservoir is supplied from the T2 PRS via the 707 zone and is controlled via SCADA.

### 6.6.12 486 Zone

The 486 zone is the lowest zone in the District, situated in the most western part of the District. This zone does not include storage and does not supply any other zones. The zone is supplied by four PRSs: CX27K and EX22JF from the 637 zone and EX22 and EX20K from the 565 zone.

### 6.6.13 Boot and Bennett Areas

The Boot and Bennett areas are satellite District service areas supplied by the Vista Flume and located to the east of the main service area. The Boot area is located adjacent to the primary service area and relies on the flume to maintain service pressures. The Boot area is split into two pressure zones, the 870 and 850 zones, each connecting to the flume at different locations resulting in the 20 foot difference in head between the two zones.

The Bennett area is located east of the Boot area, south of the Vista Flume. Like the Boot service area, the Bennett service area is split into two pressure zones, the 980 and the 898. However, the Bennett area is more complex and includes two reservoirs and

two pump stations. The 0.20 MG MD Reservoir is located in close proximity to the flume, which sets the grade in the reservoir and the 898 zone. The 1.30 MG Deodar Reservoir is located south of the MD Reservoir in the Bennett service area and provides head for the Knob Hill PS (PS 3) and Deodar PS (PS 4), which lift flow to the 980 zone.

## 6.7 Condition Assessment Summary

As part of this Master Plan, condition assessment of the District's pipelines and reservoirs was conducted. The assessment of the pipelines is based on a review of the District's datasets and workshops with District staff. This information was used to develop an approach to repairing or replacing aging infrastructure.

The assessment of the reservoirs is based on field investigation of 10 of the District's 12 reservoirs. Two reservoirs, HP and E Reservoirs, were not inspected. HP Reservoir was out of service, undergoing rehabilitation due to corroded and failing prestressed wire wrap. E Reservoir was in service, but did not require inspection since it is scheduled for replacement

The detailed findings of the condition assessments are provided in **Appendix A - Water Pipeline Condition Assessment** and **Appendix B - Reservoir Condition Assessment Technical Memorandum (TM)**. A brief summary of those assessments is provided in the following sections and recommendations are included in the Capital Improvement discussion in **Chapter 9**.

### 6.7.1 Pipeline Condition Assessment

The District owns 429 miles of water main infrastructure and manages an additional 10 miles of privately owned water main infrastructure. As the system continues to age and deteriorate, one of the District's primary goals is to cost effectively sustain desired service levels. To accomplish this, the District has initiated this effort to continuously improve the way distribution main assets are managed. The three primary objectives of this project are to:

1. Establish prudent, transparent, and defensible investment levels that will enable the District to sustain desired levels of service as the system continues to age and deteriorate.
2. Focus those investments to ensure ratepayers realize the greatest return on their investment.
3. Optimize existing practices.

For distribution mains, the District has break data going back to 1992. The District has documented 2,230 breaks from 1992 through January of 2017, of which 839 were classified as occurring on a mainline (as opposed to a service, valve, or other appurtenance) and were used in this analysis. The data is of sufficient quantity and quality to build risk and investment models that meet the three objectives of this project.

Industry experience tells us that pipeline performance and useful life can vary significantly from one construction project to the next. Construction project data provided insight regarding the relative quality of the material used, transport, and handling procedures, installation quality, backfill quality, and construction management quality.

Analysis of the District’s break data validates that District pipeline performance varies significantly by project.

**Figure 6-3** summarizes project number performance by cumulative breaks and lengths. As shown, a small percentage of system piping is responsible for most of the breaks (e.g., 80 percent of all breaks have occurred on projects that represent only 12 percent of the entire system length). The relationship between project number and performance was found to be significant, thus construction project numbers were used as the basis for sizing and prioritizing renewal investments.

**Figure 6-3. Small Percentage of Pipe is Responsible for Most Breaks**

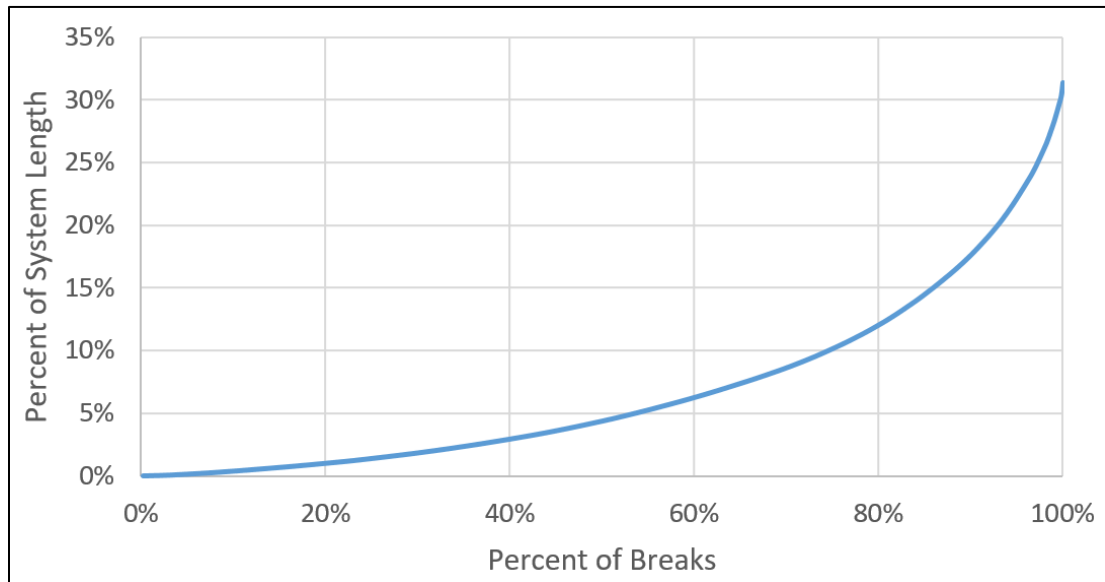

Based on the data, historic break count was also found to be a good indicator of performance, as the percent of projects that broke again increased as the break count increased, and the duration between subsequent breaks became shorter.

To better understand how various investment levels will impact future service levels, a break forecasting model was developed. This model applies prudent, transparent, and reproducible methods to District data to forecast how many breaks will occur in each year over the planning horizon (through 2040). Three investment scenarios were modeled:

- Scenario 1 – Sustain Existing Investment Levels
- Scenario 2 – Sustain Existing Service Levels
- Scenario 3 – Double Existing Investment Levels

It is anticipated that these scenarios, in conjunction with engineering and operational judgment, will enable the District to make informed renewal decisions, with confidence that desired levels of service will be maintained. Selection of the appropriate investment level should be made by District management and should strike the appropriate balance between desired long term service level goals and the associated cost to achieve that service level.

The next objective was to focus those investments to ensure ratepayers realize the greatest return on their investment. A consistent, transparent, efficient, prudent, and defensible approach was defined to select an appropriate investment level through the identification and prioritization of water pipeline replacement projects. To accomplish this, a project risk score was developed that quantifies relative risk on a scale of zero (lowest risk) to 100 (highest risk). This methodology considers the consequence of failure (CoF), the likelihood of failure (LoF), and hydraulic limitations, as shown in **Figure 6-4**.

**Figure 6-4. Risk Calculation Method**

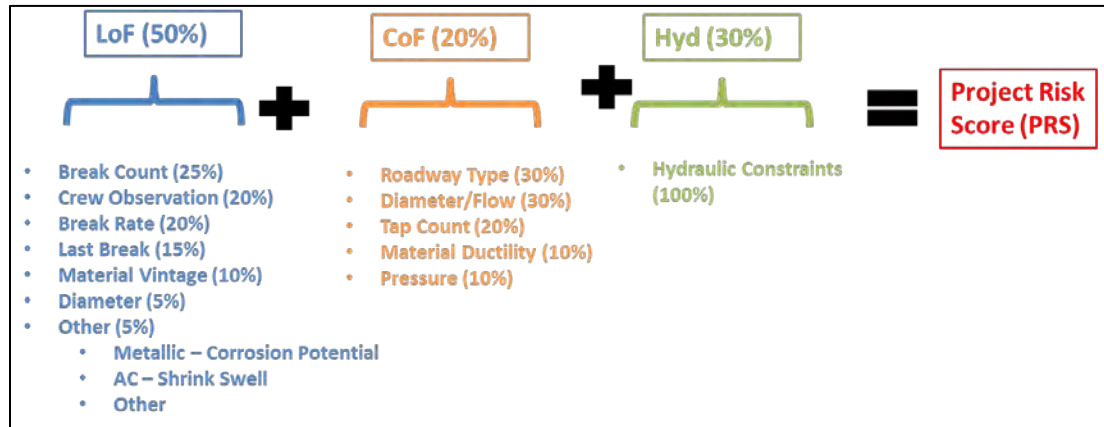

This methodology was applied to the District’s distribution mains. The resulting risk map is provided in **Figure 6-5**.

Historically, the District has typically used the open-trench replacement method. Based on regulatory challenges, useful life extension uncertainty, additional research needed, and limited economies of scale; it is recommended that the District continue to use open-trench replacement as the primary renewal method. However, the viability of alternative renewal solutions should be evaluated on a project specific basis, particularly where the integrity of the host pipe can be cost effectively determined and site-specific factors lend themselves to alternative renewal solutions.

Figure 6-5. Pipeline Condition Assessment Project Risk Map

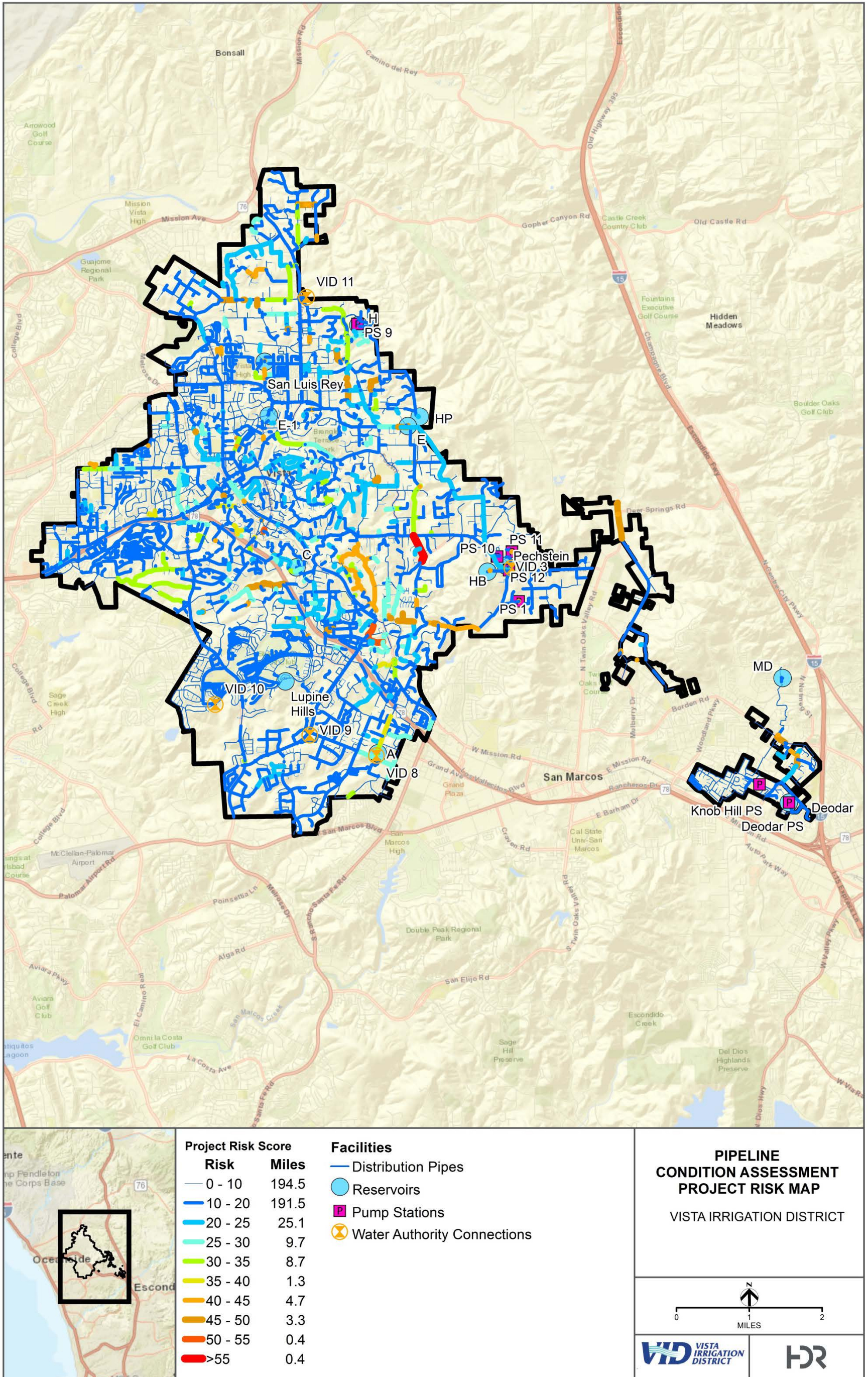

PATH: C:\USERS\JENGLESO\DOCUMENTS\PROJECTS\VISTA\_IRRIGATION\_DISTRICT\2016\_WATER\_MASTER\_PLAN\_UPDATE\_10043046\INFOWATER\VID\_RISKASSESSMENT\_CIP\_11X17\_I.MXD - USER: JENGLESO - DATE: 1/22/2018



*This page is intentionally blank.*

## 6.7.2 Reservoir Condition Assessment

Condition assessment inspections of 10 of the District's 12 potable water reservoirs were completed in November 2016. Two reservoirs, HP and E Reservoirs, were not inspected. HP Reservoir was out of service, undergoing rehabilitation due to corroded and failing prestressed wire wrap. E Reservoir was in service, but did not require inspection since it is scheduled for replacement. Confined space entry of the reservoirs was not conducted; however visual inspection of the reservoir's interior from access hatches was attempted when it was deemed safe to do so.

The exterior inspections were intended to document the current condition of the civil site, corrosion, and structural aspects of the reservoirs. Field activities completed during these field visits included:

- Perimeter, site and drainage inspection
- Structural inspection
- Exterior coatings inspection
- Reservoir Climb and roof inspection
- Non entry, visual hatch inspection

The findings of the inspection of the District's reservoirs were used to recommend and prioritize improvements for the rehabilitation or replacement of reservoir equipment and identify any additional assessments required. The overall approach and detailed inspection with photographic documentation are included in **Appendix B - Reservoir Condition Assessment TM**.

The HDR standardized Condition Assessment Ratings System (CARS) was utilized to guide the inspection team while conducting the reservoir inspections. CARS promotes consistency from site to site to facilitate proper prioritization of the reservoirs civil site, corrosion and structural aspects.

The criteria specified in the CARS are grouped into four categories as follows:

1. Structural
2. Site (non-reservoir)
3. Aesthetic (reservoir only)
4. Safety/Security

The civil/site and corrosion and structural recommendations listed for each reservoir address the deficiencies noted during the field inspections. The civil/site, corrosion, and structural recommendations pertain to ongoing monitoring, minor maintenance, and repair work. The recommendations for further investigation include potentially larger scale improvements and recommendations, such as interior cleaning and inspection or seismic evaluations.

Each criterion was scored on a scale or listed as Not Applicable. The scoring criteria are displayed in **Table 6-8**.

**Table 6-8. Reservoir Condition Scoring Criteria**

Score	Description	Phasing
0	No action required	-
1	Minor (7plus years)	Long-Term
3	Moderate (2 to 6 years)	Mid-Term
5	Immediate (0 to 2 years)	Near-Term
N/A	Not Applicable	-

Each reservoir received a score for Civil/Site components, Civil/Corrosion components and Structural components. Each category of components was first normalized to a 100-point scale and then weighted based on potential risk. Site and civil/corrosion were weighted at 20 percent each and structural was weighted at 60 percent. Weighting the structural components at a higher value allowed for a more accurate prioritization of the projects to address safety and reliability concerns first.

The scoring components, rankings, and recommendations for each inspected reservoir are provided in **Table 6-9**. Detailed recommendations are provided in **Appendix B**. The top three reservoirs in the most need for near term repair and/or replacement, based on the rankings, are Deodor, Pechstein and A Reservoirs. All three require additional internal inspections to determine the potential need for complete replacement. The recommended capital improvement projects for all of the reservoirs are discussed further in **Chapter 9**.

**Table 6-9. Reservoir Condition Findings and Recommendations**

Rank	1	2	3	4	5	6	7	8	9	10	
Reservoir	Deodar	Pechstein	A	HB	Lupine Hills	E1	MD	C	H	San Luis Rey	
Recommended Improvements	Access Road	●	●		●	●		●	●	●	
	Fences and Gates	●		●	●			●	●		●
	Trees and Vegetation			●		●	●	●		●	
	Signage and Safety Signage	●	●	●	●		●	●	●	●	●
	Drainage		●								
	Site Piping and Appurtenances			●	●						
	Roof Hatch	●	●	●	●	●	●	●	●	●	●
	Roof	●	●	●	●	●	●	●	●	●	●
	Handrails, Ladders, and Stairs	●	●		●	●	●	●	●	●	
	Hatches and Doors		●		●						
	Overflow Pipe	●								●	
	Reservoir Exterior Wall	●	●	●	●	●	●	●	●	●	
	Vent		●		●	●	●		●		●
	Stability/ Geotechnical/ Foundation	●			●			●			
	Interior Structure		●	●			●				●
	Further Investigation	●	●	●	●	●	●	●	●	●	●

● Near Term Improvements (0 to 2 years)      ● Mid Term Improvements (2 to 6 years)      ● Long Term Improvements (7plus years)



*This page is intentionally blank.*

## 7 Existing System Analysis and Recommendations

This chapter briefly summarizes the software selection process and validation of the new hydraulic model, and subsequently describes hydraulic analyses of the existing system. Based on the evaluation criteria provided in **Chapter 5**, existing system deficiencies were determined and projects to improve system performance were recommended. Recommended improvements are proposed to improve basic operations, bring the water system in compliance with hydraulic evaluation criteria, and increase system reliability.

### 7.1 Model Selection, Development, and Validation

The computational hydraulic model of the District's distribution system has passed through three main phases in its historical development. In its original phase, the hydraulic model was constructed by the District using Cybernet. This original model included information relevant to the distribution system at the time, including pipeline data (alignment, length, diameter, and roughness coefficient), node data (AADs and elevations), reservoir dimensional data, and valve data (location, type, and size).

In the second phase of model development, as part of the 2000 Master Plan effort, the model was converted from Cybernet to H2ONET Version 3 by Innovyze. As part of this process, the model was also updated to represent the District's distribution system at the time. In addition, the model was verified using a combination of field and SCADA data collected over a 24-hour period from November 9-10, 1999. As part of the model update, special attention was given to the modeling of combination PSRs (e.g., pressure reducing/sustaining valves), which were not offered as a standard control valve option in H2ONET Version 3.

The third phase of model development was conducted as part of this Master Plan. Between the 2000 Master Plan and this Master Plan, the H2ONET version of the hydraulic model was maintained and updated by the District. As part of this Master Plan, the District's model was converted to a new modeling software and updated based on available information (e.g., GIS, operations information, billing data, and supply data). The updated model was then validated based on current operations information, SCADA data, and hydrant tests. The validated model was then used to conduct an analysis of the capacity and reliability of the existing and future distribution systems based on the criteria developed in **Chapter 5**.

#### 7.1.1 Model Conversion to InfoWater

As part of this Master Plan, the District's existing H2ONET model was converted to InfoWater Version 12.2 by Innovyze. InfoWater includes features that were more desirable to District staff than H2ONET, including the ability to run the modeling software in ArcMap. Prior to converting the model to InfoWater, a comparison of seven of the leading water distribution system modeling software packages was developed for the District's review, and it was determined that InfoWater was the best fit for the District's

needs. H2ONET and InfoWater are both distributed by Innovyze, and InfoWater includes the ability to automatically import H2ONET models, so conversion between the two software packages was streamlined. A summary of the model software selection process is included in **Appendix D - Hydraulic Model Software Selection TM**.

As part of the model conversion to InfoWater, the two smaller H2ONET models of the Boot and Bennett systems were also imported into the new InfoWater model.

### 7.1.2 Model to Geographic Information System Relationship

As part of this Master Plan, the District's hydraulic model was updated based on the latest GIS information in the District's geodatabase (gdb). As part of this process, the District explored the practicality of establishing a one-to-one model-to-GIS relationship where the modeled facilities could be linked to the gdb facilities via a unique identification number. A cost, benefit analysis was performed and it was determined that the costs of establishing a one-to-one relationship with the GIS would outweigh the benefits. The existing hydraulic model is skeletonized and represents the distribution system with fewer primary distribution pipes than are included in the gdb. Increasing the number of pipes in the model could make the model unnecessarily complex leading to increased errors, longer run times, and resulting in a model that is more difficult to manage. Additionally, matching the model pipes with the GIS would require an upgraded license to accommodate the large number of pipes in the gdb. A summary of the cost/benefit analysis of establishing a one-to-one relationship between the model and the District's GIS is included in **Appendix E - Hydraulic Model GIS Integration TM**.

Maintaining a relationship between the model and the District's GIS information is a priority, even if the relationship is not a one-to-one facility relationship with the gdb. The selection of InfoWater as the software for the model conversion allows for a visual comparison of the relationship between the gdb and the model in ArcMap. In ArcMap, the gdb facilities can be overlaid on the modeled facilities allowing for a quick comparison.

### 7.1.3 Modeling Combination Regulators

In addition to converting the District's H2ONET model to InfoWater, the approach to modeling the combination PRSs was enhanced as part of this Master Plan. A review of the ability of InfoWater to represent combination PRSs is provided in **Appendix D**.

At the time of the 2000 Master Plan, the District operated 17 combination PRSs. Combination PRSs have the ability to modulate between pressure reducing and pressure sustaining modes by throttling the flow to achieve the desired pressure settings upstream and/or downstream. Since valves in H2ONET are either pressure reducing/regulating valves (PRVs) or pressure sustaining valves (PSVs) and not both, a PRV and a PSV were modeled in parallel to represent the combination PRS. Logic controls were used to open one and close the other, or vice versa, and then switch if necessary, depending on pressures upstream and downstream of the valve.

For this Master Plan, the model was updated to represent the combination PRSs as a PSV and a PRV in series (up-gradient to down-gradient) with no logic controls. When reviewing options of modeling software for the model conversion, the ability of the software to properly represent combination PRSs was a primary concern.

## 7.1.4 Operations

Operations information in the hydraulic model was updated based on information provided by District Operations staff including facility settings, SCADA data, and conceptual information about how the distribution system is operated.

As discussed in the previous section, the operational control information in the hydraulic model was updated to incorporate combination PRSs without logic controls. PRS settings were updated in the model based on set points provided by Operations staff. Settings were included for manually adjusted PRSs and PRSs controlled by the SCADA system. PRS settings included in the model are listed in **Chapter 6**.

## 7.1.5 Demands

Model demands were developed based on calendar year 2014 billing and supply information as discussed in **Chapter 3**. Billing data were provided as bimonthly water use volumes. Billing accounts were linked to a meter GIS layer from the District's gdb, which provided the spatial location of each meter. Water supply data were also provided by the District and were used to estimate water loss. Operations SCADA data were used to develop updated diurnal patterns. The development of updated existing system demands are discussed in detail in **Chapter 3**.

## 7.1.6 Model Validation

Following the existing system model update, the model was validated to demonstrate that the updated model represents the real world distribution system. Hydraulic model validation consisted of two main stages including macro level verification and micro level calibration. Model validation is discussed in more detail in **Appendix F - Hydraulic Model Validation TM**.

Macro level verification consisted of adjusting the model for demand distribution, diurnal patterns, water loss, and system operations. The goal of macro level verification is to demonstrate that the model represents system demands and behavior during extended period simulation (EPS) in a qualitative comparison with SCADA data. Model verification was performed for both summer and winter demand conditions based on supply, demand, and SCADA data for August 2016 and February 2015, respectively. A qualitative comparison assessment was performed based on tank levels for the EPS model output and available SCADA data for each of the verification scenarios. Comparing the model results with the SCADA data indicated that the model acceptably represents the real world system operations for both the summer and winter verification scenarios. Comparison graphs are included in **Appendix F**.

Micro level calibration consisted of comparing model results with system response to hydrant tests. The goal of micro level calibration is for model results to replicate hydrant test field data for static and residual hydrant pressures in a quantitative comparison. Hydrant tests were performed in July 2017, over a 2 day period, and consisted of 21 individual tests. Each test consisted of a flow hydrant and two residual hydrants. The hydrant tests are discussed in more detail in **Appendix G - Fire Flow Test Report**. Based on comparisons of model output with the field data collected as part of the hydrant tests, it was determined that the modeled hydrant test results match the field data to within 10 percent accuracy for each of the tests. Therefore, the updated model was considered calibrated for the purposes of this Master Plan. A comparison table of field data and model output for the hydrant tests is included in **Appendix F - Hydraulic Model Validation TM**.

## 7.2 Existing System Analysis

The updated and calibrated InfoWater model was used to analyze the District's existing distribution system, based on the planning and design criteria defined in **Chapter 5** to identify potential deficiencies. **Chapter 5** indicates three primary system conditions for applying the criteria for system evaluation including PHD, MDD +FF, and MinDD. MinDD simulations were run to identify high pressures and to evaluate water age.

### 7.2.1 Maximum Day and Peak Hour Demand

Maintaining required pressures under high demand conditions is the District's primary concern with regard to system performance evaluation. The District's main distribution system is extremely dynamic. Changes in water supply or demand in one pressure zone can affect hydraulic conditions in all other areas of the system due to the large number of interzone connections, such as PRSs and pump stations. Because of the complex interrelationship between pressure zones, steady state (SS) model runs would not represent the temporal changes that occur as the distribution system adjusts to MDD conditions leading up to a PHD event. In order to account for this, EPS model runs were used to represent PHD conditions in the model. MDD EPS model runs were performed, and the peak model result values were used to represent PHD conditions. MDD EPS model runs were also performed to evaluate reservoir drain/fill operations.

Model valve settings were based on existing system settings as described in **Chapter 6, Table 6-4, and Table 6-5**. Water Authority flows were adjusted to provide the average supply to meet demand and maintain system operations. Flows were introduced at all turnouts except for VID 8, as VID 8 is not widely used and was recommended to be abandoned in the 2000 Master Plan. Flow from the Vista Flume was also included in the model. Modeled supply flows for the MDD EPS scenario are listed in **Table 7-1**.

**Table 7-1. Maximum Day Demand Supply Summary**

Supply Location	Pressure Zone	Flow (under MDD settings)	
		(gpm)	(cfs)
Vista Flume	837	7,207	16.1
VID 3	984	3,742	8.3
VID 8	837	-	-
VID 9	837/707	5,468	12.2
VID 10	707	1,841	4.1
VID 11	810/668	6,621	14.8
Total		24,878	55.4

cfs - cubic feet per second; gpm – gallons per minute; VID – Vista Irrigation District

Model results for the existing system PHD scenario indicate some high elevation, low-static pressure areas, primarily in the 565 and 627 zones. Model results also indicate that a few relatively high elevation locations on the periphery of the 984 zone may experience pressures below the minimum required pressure criteria of 40 psi under modeled PHD conditions.

Existing system model results also indicate that no pipelines exceed the high velocity criteria during PHD. The results indicate that some pipes exceed the high headloss criteria throughout the distribution system at various locations throughout the system including in the 565, 668, 837 zones, and in the 707 zone near the A Reservoir. Model results for the existing PHD scenario are shown in **Figure 7-1**.

*This page is intentionally blank.*

Figure 7-1. Existing System Peak Hour Demand Model Results

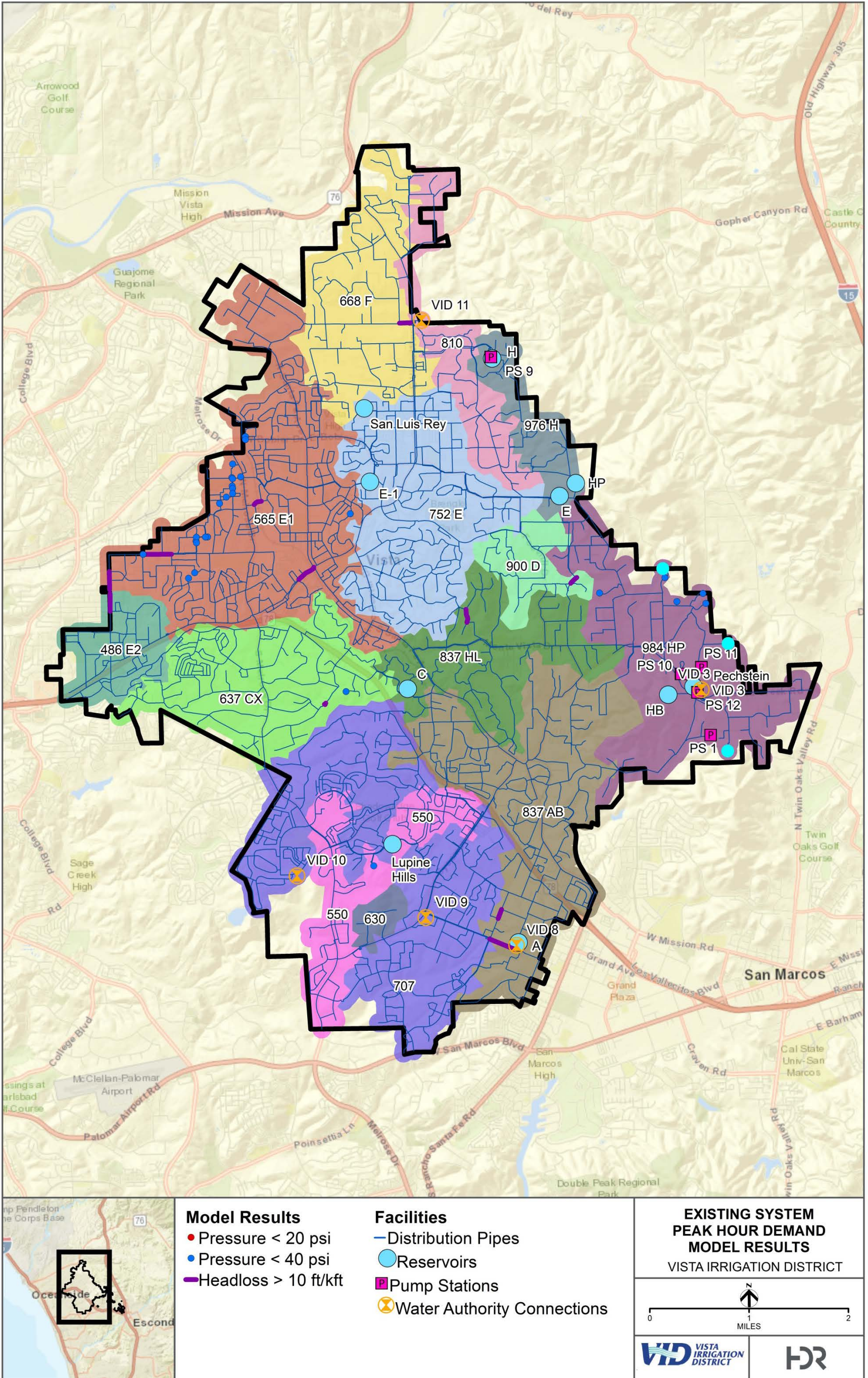

PATH: C:\USERS\JENGLESO\DOCUMENTS\PROJECTS\VISTA\_IRRIGATION\_DISTRICT\2016\_WATER\_MASTER\_PLAN\_UPDATE\_10043046\INFOWATER\VID\_EXISTING\_PHD\_DEFICIENCIES.MXD - USER: JENGLESO - DATE: 1/16/2018



*This page is intentionally blank.*

## 7.2.2 Maximum Day Demand plus Fire Flow

Fire flow simulations were run using the InfoWater Fireflow simulation module. Required fire flows were loaded to the model based on the planning criteria presented in **Chapter 5**, and the existing land use presented in **Chapter 2**. Fire flow criteria include minimum residual pressure and maximum velocity limits of 20 psi and 16 fps, respectively, during MDD+FF conditions. Fire flow deficiencies within the existing system are primarily located at hydrants on small diameter, dead-end pipes. Under the District's rehabilitation program, these pipelines will be considered for upsizing when condition assessment indicates a need for replacement.

## 7.2.3 Minimum Day Demand

Maximum system pressures and water age were analyzed using MinDD EPS. These model simulations were run with flow supplied by the Vista Flume and the Water Authority connections, similar to the MDD scenario but scaled back to meet the average MinDD. The results are illustrated in **Figure 7-2**. Based on the evaluation criteria of 150 psi for maximum desired pressure, the model results indicate potentially high system pressures primarily in the 837, 752, and 707 zones. Additionally, results show high pressures in the northern area of the system in the 668 and 810 zones. The model results suggest local elevations primarily contribute to the pressures exceeding the evaluation criteria (e.g. located near the borders of the lower zones). Most of the high pressure model nodes are located in the 837 zone.

MinDD model simulations were also run to assess water age. Model results, as shown in **Figure 7-3**, indicate under these conditions, some areas of the system experience water age older than 10 days. Primarily, the northern portions of the 565 zone and the 707 zone show older water age. Additionally, the western area of the 637 zone shows higher water age. These areas of the system do not have source water connections and rely on gravity flows from other zones, which increases the age of the water used to satisfy local demands. Recommendations for improving water age during low demand conditions include operational adjustments limiting the amount of water stored in reservoirs to the minimum required by the storage requirements discussed in **Chapter 4**, which would accelerate turnover within the reservoirs and improve water movement within the system.

As system demands seasonally decrease, the required volume of operational storage decreases. Based on demands and system performance, reservoirs could also be taken offline during periods of low demand. For example, the E-1 Reservoir provides redundant storage in the 565 zone that may not be needed during low demand periods. However, during low demand periods when planned shutdown of Water Authority Aqueduct connections occur, these reservoirs are critical to providing supply to District customers and should not be taken off line.



*This page is intentionally blank.*

Figure 7-2. Existing System Minimum Day Demand Pressures

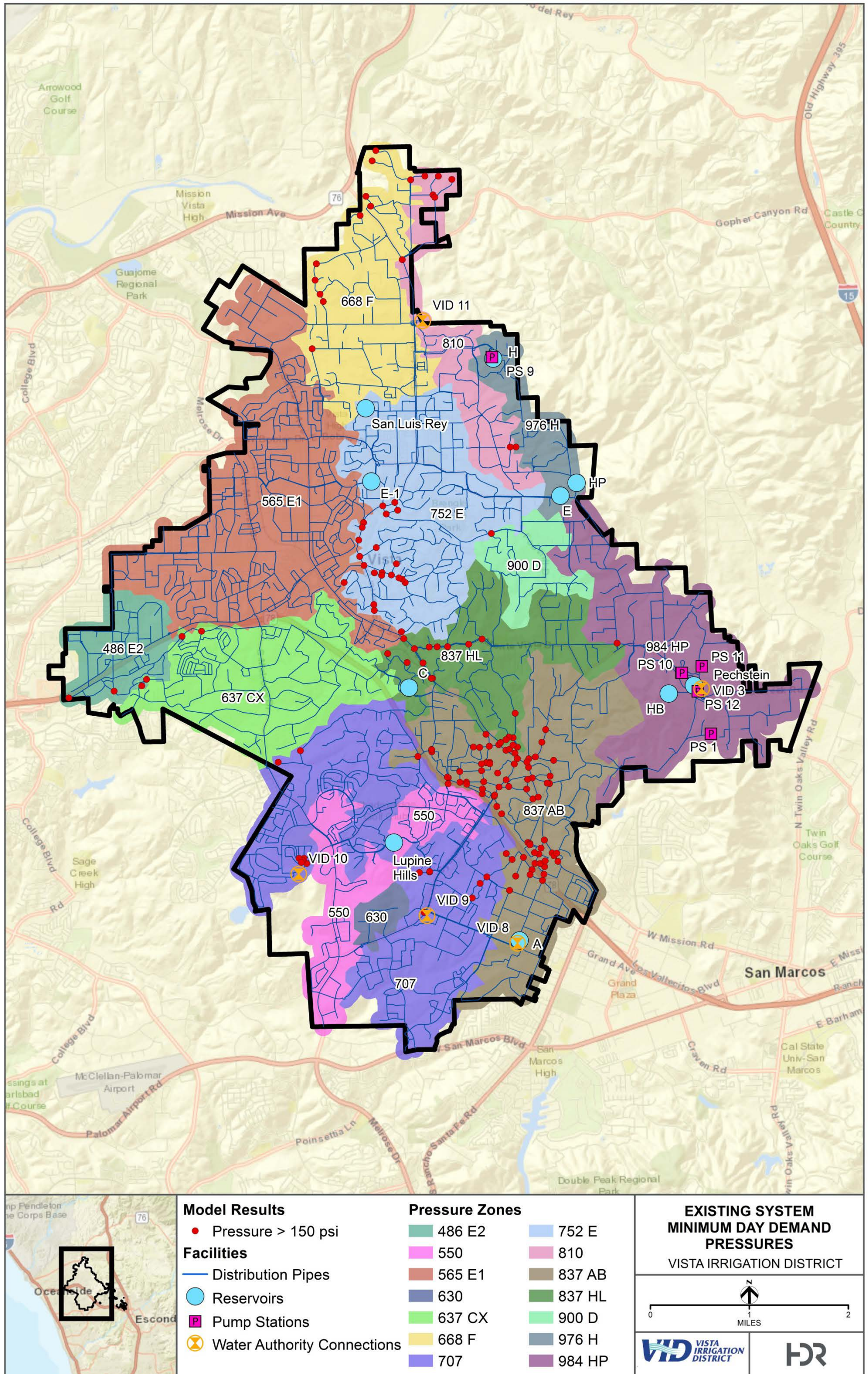

PATH: C:\USERS\JENGLESO\DOCUMENTS\DOCUMENTS\PROJECTS\VISTA\_IRRIGATION\_DISTRICT\2016\_WATER\_MASTER\_PLAN\_UPDATE\_10043046\INFOWATER\VID\_EXISTING\_MINND\_DEFICIENCIES.MXD - USER: JENGLESO - DATE: 1/16/2018

*This page is intentionally blank.*

Figure 7-3. Existing System Minimum Day Demand Water Age

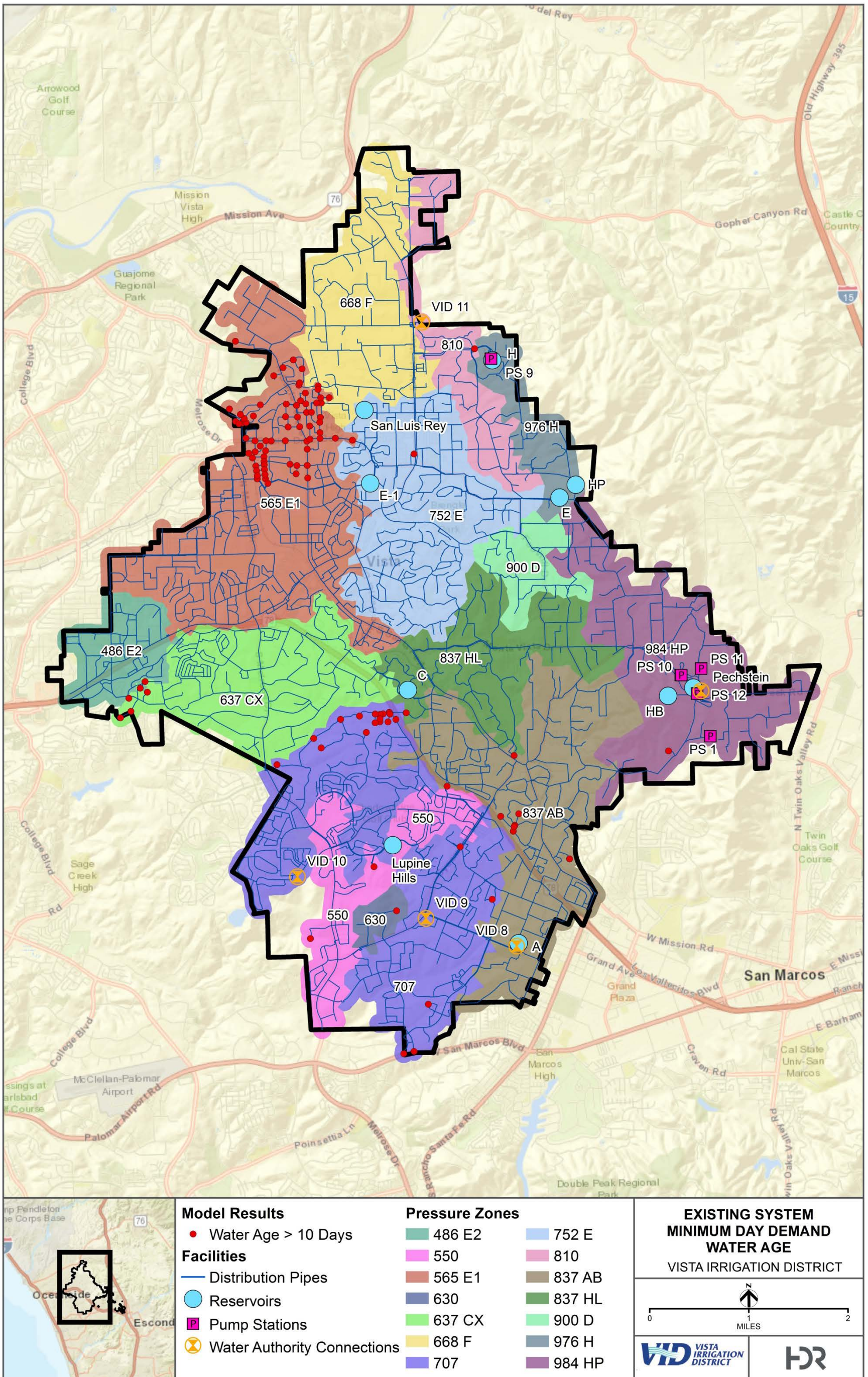

PATH: C:\USERS\JENGLES\DOCUMENTS\DOCUMENTS\PROJECTS\VISTA\_IRRIGATION\_DISTRICT\2016\_WATER\_MASTER\_PLAN\_UPDATE\_10043046\INFOWATER\VID\_EXISTING\_MINDD\_WATER\_AGE.MXD - USER: JENGLES - DATE: 1/16/2018



*This page is intentionally blank.*

## 7.3 Recommended Existing System Improvements

The recommended existing system improvements are summarized in **Table 7-2** and their locations are shown in **Figure 7-4**. These recommended improvements were identified in the analysis with the InfoWater hydraulic model, as well as discussions with District staff. Some of the projects developed as part of this analysis had also been recommended as part of the 2000 Master Plan. For reference, the corresponding 2000 Master Plan project numbers are included in **Table 7-2**. The 2000 Master Plan recommended improvement project descriptions are included in **Appendix H**, for reference.

A review of the existing system hydraulic model results indicates that there are no hydraulic deficiencies identified based on current demand conditions that warrant improvement projects. Areas of the system, primarily relatively high elevation areas of the 565 and 976/984 zones, do experience periodic operating pressures below the desired 40 psi criteria at PHD. While operating pressures below 40 psi are not ideal, the pressures are due to local high elevations and do not drop below the 20 psi criteria, and therefore do not warrant improvement projects.

Additionally, model results indicate that some pipes in the existing system may experience headloss higher than the desired 10 feet per 1,000 feet at PHD. However, the headloss in these pipes are not attributed to low system pressures, and model results indicate that velocity in these pipes does not exceed the 8 fps criteria at PHD. Therefore, these pipes do not negatively affect system operation and do not warrant system improvements.

As the existing system model results did not indicate the need for hydraulic deficiency improvement projects, the focus of the existing system assessment was shifted to improving system redundancy.

The first two improvement projects (EX-1 and EX-2) listed in **Table 7-2** address the addition of a third PRS providing flow to the 637 zone and takes advantage of the robust transmission system along Santa Fe Avenue. Project EX-1 includes the construction of a PRS to convey flows from the 837 zone to the 637 zone. Project EX-2 provides additional capacity to relieve high velocities resulting from the construction of EX-1. EX-1 was included in the 2000 Master Plan as part of ULT-5 and ULT-20. EX-2 was included in the 2000 Master Plan as part of ULT-1.

Project EX-3 consists of a large diameter pipe alignment to provide redundant supply out of Pechstein Reservoir. The alignment parallels an existing large diameter pipe connecting Pechstein Reservoir to the 837 zone in Buena Creek Road with additional new pipe in Buena Creek Road and Monte Vista Drive, relocating the cross country alignment recommended in the 2000 MP as EX-6.

Project EX-4 consists of providing a third PRS feed to the 900 zone. The project would connect the 976/984 zone to the 900 zone via new pipe and a PRS between San Clement Way and Huntalas Lane.

Project EX-5 consists of constructing a new pump station at E Reservoir that would allow flow to be conveyed from the 752 zone to the 837 or 976/984 zone, adding operational reliability and flexibility to the existing system.

Detailed descriptions of the individual recommended projects are provided in the following paragraphs and project locations are indicated in **Figure 7-4**.

**Table 7-2. Recommended Existing System Improvements**

Job Number	Description	Diameter (Inches)	Length (Feet)	Reason	2000 Master Plan Project Number(s)
EX-1	Construct new 637 zone PRS along Civic Center Drive	N/A	N/A	Redundant connection to the 637 zone	ULT-5 ULT-20
	New 12-inch pipe in Postal way from E43 PRS to Civic Center Drive and southwest down Civic Center Drive to new 637 PRS	12	3,211		
	Parallel 8-inch pipe in Civic Center Drive from E43 PRS to Phillips Street	8	241		
EX-2	Parallel 12-inch pipe in South Santa Fe Avenue from Monte Vista Drive to E43 PRS and continuing to Civic Center Drive	12	2,665	High velocities pipes in South Santa Fe Avenue, resulting from the addition of EX-1, and increasing capacity to 18-inch pipe installed in South Santa Fe Avenue at Civic Center Drive	ULT-1
EX-3	New 30-inch pipe from Pechstein Reservoir to PS 10	30	645	Redundant feed out of Pechstein to 837 zone	EX-6 (variant)
	New 24-inch pipe parallel to existing 26-inch pipe from PS 10 to Sugarbush Drive parallel to Buena Creek Creek Road	24	3,386		
	New 24-inch pipe in Buena Creek Road from Sugarbush Drive to Monte Vista Drive	24	3,126		
	New 24-inch pipe replacing existing 12- and 10-inch pipe in Monte Vista Drive from Buena Creek Road to La Rueda Drive	24	1,759		
EX-4	Construct new PRS connecting 976/984 zone and 900 zone between San Clemente Way and Huntalas Lane	N/A	N/A	Redundant connection to the 900 zone	
	New 8-inch pipe connecting 976/984 zone and 900 zone via new 900 PRS	8	1,006		
EX-5	New PS at E Reservoir	N/A	N/A	Provides flexibility for conveying water from the 752 zone to 837 and 976/984 zones	
	New pipe connecting E Reservoir PS to desired zone(s)	Up to 24	up to 1,000		

PRS - pressure regulating/reducing station; PS – pump station

Figure 7-4. Recommended Existing System Improvements

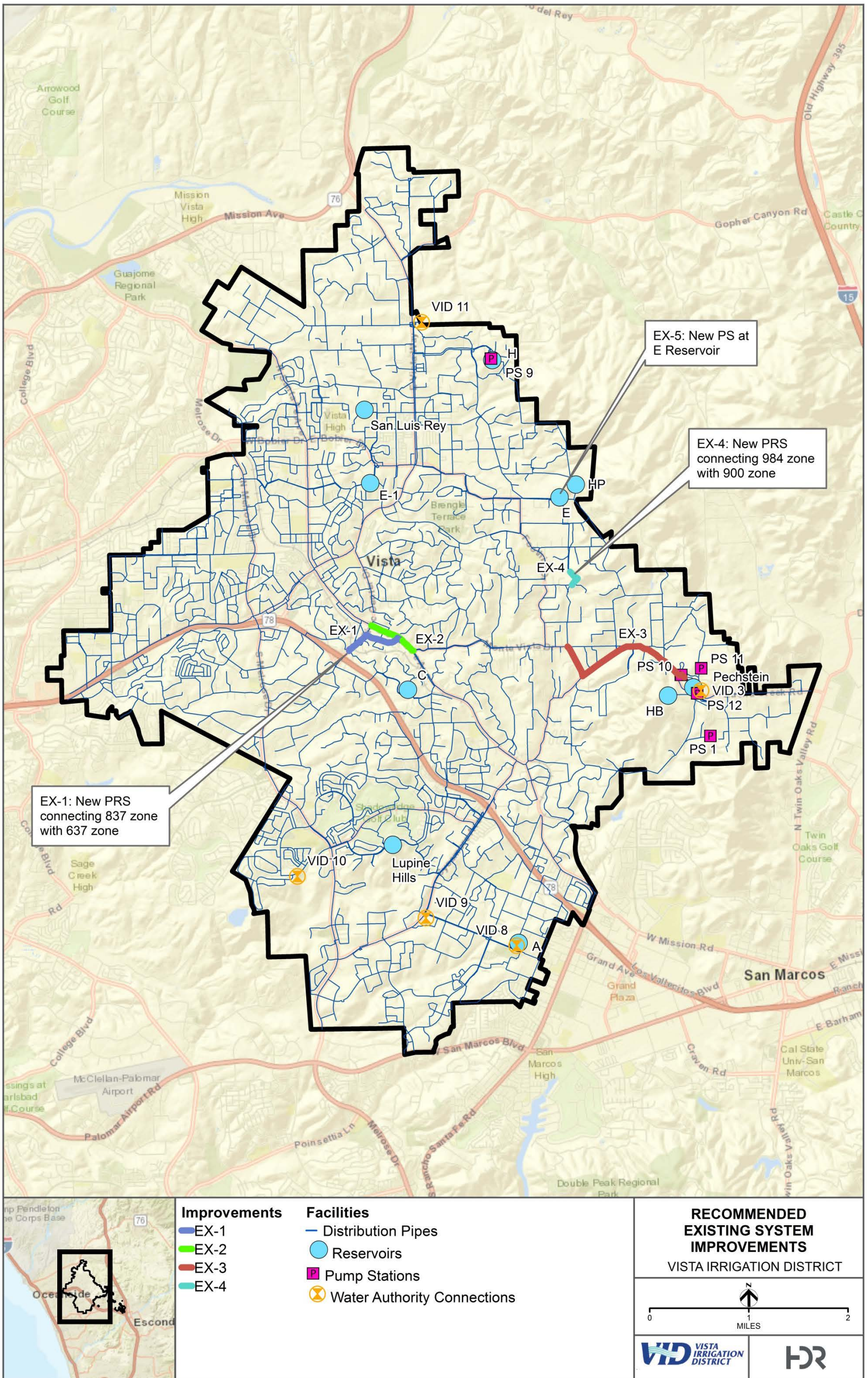

PATH: C:\USERS\JENGLESO\DOCUMENTS\DOCUMENTS\PROJECTS\VISTA\_IRRIGATION\_DISTRICT\2016\_WATER\_MASTER\_PLAN\_UPDATE\_10043046\INFOWATER\VID\_EXISTING\_CIP.MXD - USER: JENGLESO - DATE: 1/16/2018



*This page is intentionally blank.*

### 7.3.1 Third Supply to 637 Zone (EX-1)

Project EX-1 should be a fairly high priority for the District. This project provides a third supply to the 637 zone. The CX28 PRS and the C Reservoir PRS are the only supplies to the zone and the C Reservoir is not large enough to supply the PHD. Project EX-1 provides an additional supply to the 637 zone from the large diameter pipe alignment in Monte Vista Drive and Santa Fe Avenue, to a new PRS near the intersection of Civic Center Drive and Phillips Street. New 16-inch diameter pipe in Postal Way and Civic Center Drive is recommended to convey flow from the existing pipe alignment in Santa Fe Avenue, just upstream of the E43 PRS, to the new EX-1 PRS.

Additional pipe is also recommended parallel to existing pipes in Civic Center Drive to avoid the potentially high velocities introduced by the new PRS. Alternatively, the existing pipe in Civic Center Drive could be replaced with a new larger diameter pipe in order to increase capacity.

The location of the new PRS with regard to the system schematic is shown in **Figure 7-5** with the PRS labeled EX-1. It is recommended that the valve be sized to convey 1,000 gpm. Approximately half of the 637 zone AAD demand (500 gpm) would be conveyed through the valve in the case of an outage of one of the two existing PRS feeds to the 637 zone; however, model results indicate that demand and reservoir fluctuations could result in approximately 1,000 gpm under PHD conditions. The pressure setting in the model was set to reduce pressures to 97 psi at an elevation of 400 feet.

### 7.3.2 Additional Capacity in Santa Fe Avenue Upstream of E43 Pressure Regulating Station (EX-2)

In the existing distribution system, two large 30-inch diameter pipes converge to a relatively small 10-inch diameter pipe at the intersection of Monte Vista Drive and Santa Fe Avenue. According to model simulations, the addition of project EX-1 potentially increases the peak hour velocities in the existing 10-inch pipe significantly enough to trigger the 8 fps evaluation criteria. The recommended solution is to install new 12-inch diameter pipe parallel to existing pipe from the intersection of Monte Vista Drive and Santa Fe Avenue to the E43 PRS. Alternatively, the existing pipe in Santa Fe Avenue could be replaced with new larger diameter pipe in order to increase capacity. This project is similar to the project ULT-1 in the 2000 Master Plan.

### 7.3.3 Second Feed out of Pechstein Reservoir (EX-3)

Pechstein Reservoir is the largest reservoir in the system with a capacity of 20.0 MG. The reservoir outlet is currently limited to a single 26-inch main connecting to the 837 zone. A redundant feed out of Pechstein Reservoir to the 837 zone was recommended in the 2000 Master Plan and is also recommended in this Master Plan. The 2000 Master Plan identified two potential alignments, the first (referred to as EX-6) being a feed to the south of the reservoir location paralleling the existing AB line, connecting the 976/984 zone to the AB PRS through a cross country alignment. However, this cross country alignment requires tunneling, is hard to access and may result in environmental permitting issues.

Therefore, the District would prefer the second, northern alignment, which consists of a 24-inch feed from Pechstein Reservoir paralleling the existing large diameter feed along Blue Bird Canyon Road to PS 10. The 24-inch pipe would continue to parallel the existing feed down Buena Creek Road to the intersection of Sugarbush Drive. From this location the new 24-inch pipe would deviate from the alignment of the existing feed and continue down Buena Creek Road to the intersection of Monte Vista Drive. From the intersection of Buena Creek Road and Monte Vista Drive, the new redundant feed would continue north in Monte Vista Drive to existing pipe in La Rueda Drive.

### 7.3.4 Third Supply to 900 Zone (EX-4)

The 900 zone is currently supplied by only two PRSs: D1 and HL16. Additionally, the zone has no storage and relies on PRS flows to satisfy demands in all conditions. District staff indicated a redundant connection to the 900 zone as a priority.

Project EX-4 recommends adding an additional PRS connecting the 900 zone to the 976/984 zone. EX-4 consists of new 8-inch pipe parallel to existing pipe alignment connecting the existing 976/984 zone pipe at the southern end of San Clemente Way and existing 900 zone pipe in Huntalas Lane. The new PRS would be installed at an accessible location along this alignment.

The location of the new PRS with regard to the system schematic is shown in **Figure 7-5**, with the PRS labeled EX-4. It is recommended that the valve be sized to convey 32 gpm, approximately one half the average demand of the 900 zone. The pressure setting in the model was set to reduce pressures to 70 psi at an elevation of 744 feet.

### 7.3.5 E Reservoir Pump Station (EX-5)

District staff indicated that a new pump station located at the E Reservoir would increase system reliability and potentially provide redundancy for certain supply interruptions by allowing the District to convey flows from the 752 zone to the 837 or 976/984 zones, all of which converge near the E Reservoir. The Water Authority connection VID 11 currently feeds into the 752 zone via the E30S PRS. In the event that the primary supplies to Pechstein, including the Vista Flume and VID 3, are offline, a pump station at E Reservoir could give the District more options for moving water from VID 11 to the higher zones of the system including the 837 and 976/984 zones.

However, preliminary model runs, with the proposed E Reservoir PS pumping into the existing system and reversing flow direction in the distribution system, indicate that this scenario may cause high pressure issues near the proposed pump station. These issues, and strategies for redundant supply and distribution when the Vista Flume and VID 3 are offline, are discussed further in **Chapter 8**.

Capacity of the proposed E Reservoir PS could be as much as 7,000 gpm under MDD conditions and no supply from the Flume or VID 3, but could be less, depending on the level of supply reliability the District wishes to achieve. For the purposes of the existing proposed improvements list, infrastructure related to the E Reservoir PS includes sufficient lift capacity to convey flows to the 976/984 zone, which is the highest head zone near E Reservoir. Head required to convey flow to the HB Reservoir in the 976/984 zone is approximately 700 feet with a flow rate of 7,000 gpm. Pipe required to connect to the 976/984 zone and convey this flow would be approximately 1,000 feet of 24-inch diameter pipe.

Figure 7-5. Existing System with Improvements Schematic

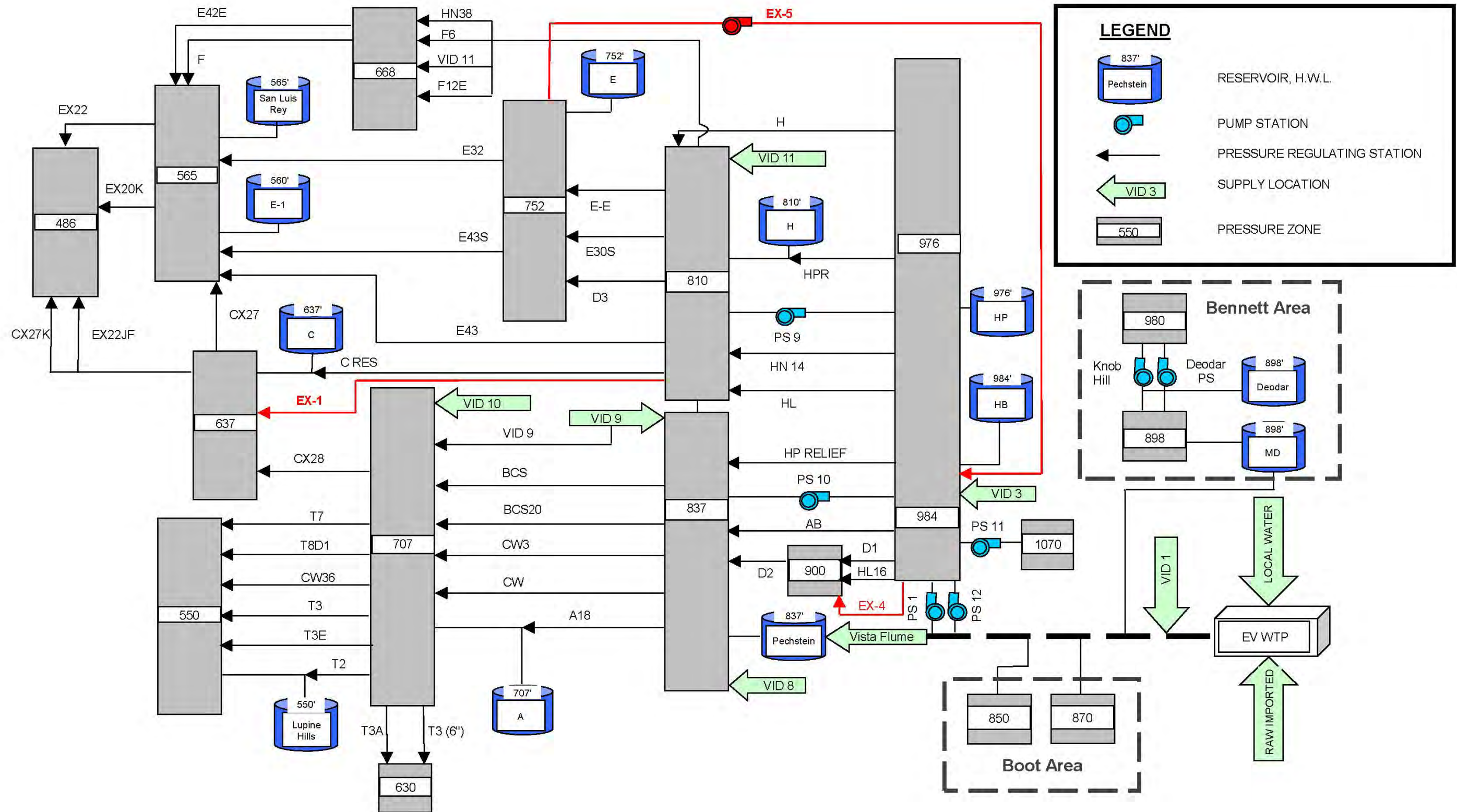

**LEGEND**

- 837' Pechstein RESERVOIR, H.W.L.
- PUMP STATION
- PRESSURE REGULATING STATION
- VID 3 SUPPLY LOCATION
- 550 PRESSURE ZONE

**Bennett Area**

- Knob Hill
- Deodar PS
- Deodar
- MD
- 898
- 980
- 984
- 976
- HP
- HB

**Boot Area**

- 850
- 870

*This page is intentionally blank.*

## 7.4 Existing System Storage Assessment

The required reservoir storage based on existing system demands and the storage criteria defined in **Chapter 4** is presented in **Table 7-3**. The storage criteria require the reservoirs to have sufficient capacity to provide 10 percent of MDD plus either the fire flow requirements within that zone, or 2 days of AAD, whichever is larger. The storage assessment is based on existing demands and available storage for each zone. Demands were estimated using the methodology discussed in **Chapter 5** and allocated to pressure zones based on meter location. It was also assumed that higher zones with excess capacity, such as H Reservoir, HB Reservoir, and HP Reservoir, would supplement storage deficiencies in lower zones.

Based on the required storage calculations, the existing system currently has 3.47 MG of excess storage capacity. However, individually, the 707, 637, 752, 565, and 486 zones all have insufficient storage based on current demands. The higher elevation zones have excess capacity, notably the 837 zone has excess storage capacity due to Pechstein Reservoir. In the case of fire or emergency, the deficient lower pressure zones could be supplied by the higher zones with excess storage via gravity.

It should be noted that the storage assessment presented in **Table 7-3** does not account for Water Authority aqueduct shutdowns. As discussed in **Chapter 4**, planned aqueduct shutdowns can last for up to 10 days during which the District must rely on its own local water supply and storage reserves to meet demands. Currently, the District relies on local water treated at the EVWTP and conveyed via the Flume during shutdowns. Scenarios and responses to planned or emergency outages are addressed in **Chapter 4**.

**Table 7-3. Existing System Storage**

Major Pressure Zone	Zone Grade (Feet)	AAD		MDD <sup>1</sup> (MGD)	Storage Criteria <sup>2</sup>					Reservoir	Existing Operational Storage (MG)	Surplus (Deficit) (MG)	
		(gpm)	(MGD)		Operational (Gallons) +	Fire (Gallons)	or	Emergency (Gallons)	=				Total (MG)
HB Zone	984, 900	687	0.99	1.98	197,811	300,000		1,978,109		2.18	HB	4.05	1.87
HP Zone	976	148	0.21	0.43	42,582	300,000		425,822		0.47	HP	4.05 <sup>3</sup>	3.58
AB/HL Zone	837	1,631	2.35	4.70	469,612	540,000		4,696,121		5.17	Pechstein	18.50	13.33
810, F Zone	810, 668	779	1.12	2.24	224,387	540,000		2,243,870		2.47	H	5.00	2.53
707 Zone	707	1,506	2.17	4.34	433,674	735,000		4,336,739		4.77	A	0.60	(4.17)
CX Zone	637	1,024	1.48	2.95	295,055	540,000		2,950,553		3.25	C	0.60	(2.65)
E Zone	752	1,508	2.17	4.34	434,278	540,000		4,342,779		4.78	E	1.20	(3.58)
550 Zone	550	684	0.98	1.97	196,905	735,000		1,969,049		2.17	LH	3.00	0.83
E-1, E-2 Zone	565, 486	3,629	5.23	10.45	1,045,227	735,000		10,452,266		11.50	SLR, E1	3.20	(8.30)
Totals		11,596	16.70	33.40	3,339,531	4,965,000		33,395,307		36.73		40.20	3.47

<sup>1</sup> MDD= 2.0 x AAD

<sup>2</sup> Operational = 0.1 x MDD

Fire = Max fire flow demand and duration within the zone per the fire flow requirements in **Table 4-3**, including 2,500 gpm for 2 hours (300,000 gallons) in wild fire interface areas.

Emergency = 2.0 x AAD

Total = Operational + the larger of fire or emergency storage criteria

<sup>3</sup> HP storage volume, prior to rehabilitation in 2017

AAD – average annual demand; gpm - gallons per minute; MG – million gallons; MDD – maximum day demand; MGD – million gallons per day

## 8 Ultimate System Analysis and Recommendations

This chapter addresses potential deficiencies in the District's potable water distribution system under ultimate demand conditions. As discussed in **Chapter 3**, ultimate system demands are based on a combination of land use demand values and planned land uses representing the service area at ultimate buildout.

This chapter also discusses projects recommended to improve system performance under ultimate demand conditions. Water distribution system facility improvements are proposed to improve basic operations, bring the water system in compliance with hydraulic evaluation criteria, and increase system reliability.

### 8.1 Ultimate System Analysis

Ultimate system analyses were based on the existing system hydraulic model, updated to include the recommended improvements discussed in **Chapter 7**, and loaded with the projected ultimate demands discussed in **Chapter 3**. Model simulations of PHD and MDD+FF were run to identify high pipe headloss, pipe high velocity, and low system pressures.

#### 8.1.1 Maximum Day and Peak Hour Demand

MDD EPS model runs were performed to identify peak hour deficiencies, similar to the model analysis runs performed on the existing system and discussed in **Chapter 7**.

Similar to the existing system analysis, Water Authority flows were introduced at all turnouts except for VID 8, and flows were adjusted to provide the average supply to meet demand and maintain system operations. Flow from the Vista Flume was also included in the model. Modeled supply flows for the MDD EPS scenario are listed in **Table 8-1**.

Model results for the ultimate system PHD scenario indicate pressures below the 40 psi preferred low pressure criteria, primarily in the western central area of the 565 zone. Model results also indicate that a few relatively high elevation locations on the periphery of the 984 zone may experience pressures below the minimum required pressure criteria of 20 psi. These are the same locations identified in the existing system analysis and discussed in **Section 7.3**. Model results also indicate some pipes exceeding the high headloss criteria throughout the distribution system, including large stretches of pipe in the 668 zone and pipes near the A Reservoir. Additionally, two reaches of pipe indicate velocity higher than the 8 fps criteria located in the 486 and 565 zones. Model results for the existing PHD scenario are shown in **Figure 8-1**.

**Table 8-1. Maximum Day Demand Supply Summary**

Supply Location	Pressure Zone	Flow (under MDD conditions)	
		(gpm)	(cfs)
Vista Flume	837	11,600	25.8
VID 3	984	4,075	9.1
VID 8	837	-	-
VID 9	837/707	5,177	11.5
VID 10	707	1,747	3.9
VID 11	810/668	6,651	14.8
Total		29,251	65.2

cfs - cubic feet per second; gpm - gallons per minute; MDD – maximum day demand; VID – Vista Irrigation District

### 8.1.2 Maximum Day Demand plus Fire Flow

Fire flow simulations were run using the InfoWater Fireflow simulation module. Required fire flows were loaded to the model based on the planning criteria presented in **Chapter 5** and the existing land use presented in **Chapter 2**. Fire flow criteria include minimum residual pressure and maximum velocity limits of 20 psi and 16 fps respectively during MDD+FF conditions. The majority of existing system fire flow deficiencies consist of hydrants located on dead-end pipes. Likewise, fire flow deficiencies within the ultimate system are primarily located at hydrants on small diameter, dead-end pipes. Under the District’s rehabilitation program, these pipelines will be considered for upsizing when condition assessment indicates a need for replacement.

### 8.1.3 Minimum Day Demand

Maximum system pressures and water age were analyzed using MinDD EPS. These model simulations were run with flow supplied by the Vista Flume and the Water Authority connections. Because there is more demand under ultimate conditions, water age improves throughout the system. Based on the evaluation criteria of 150 psi for maximum allowable pressure, the model results indicate potentially high system pressures primarily in the 837, 752, and 707 zones. These results are similar to the existing system model results, with some additional nodes within the vicinity of the areas currently identified as having high pressures. Additionally, results show high pressures in the northern area of the system in the 668 and 810 zones. The model results suggest local elevations primarily contribute to the pressure issues as defined by the evaluation criteria. Most of the high pressure model nodes are located in the 837 zone.

**Figure 8-2** displays the MinDD high pressure locations under ultimate conditions.

Figure 8-1. Ultimate System Peak Hour Demand Model Results

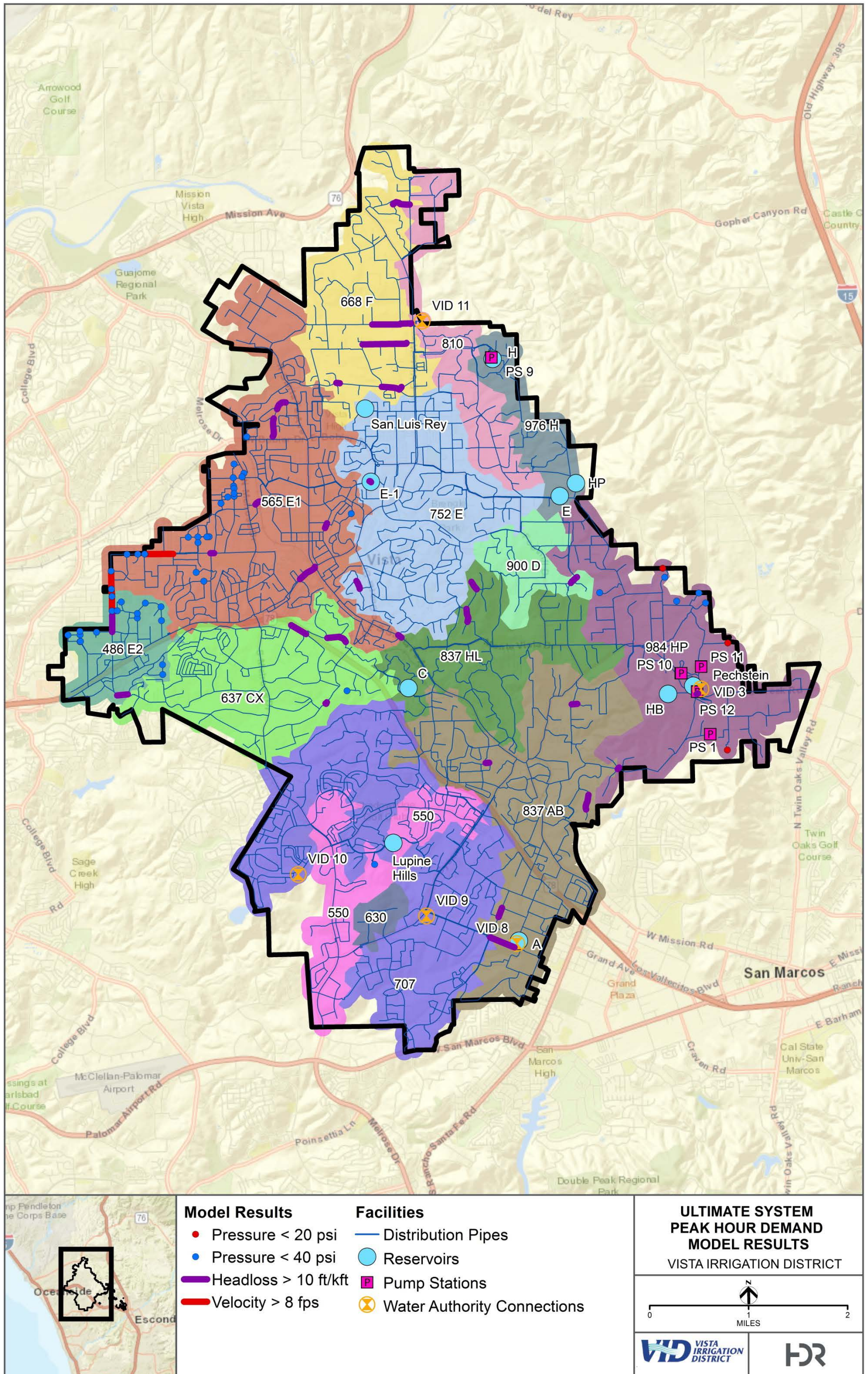

PATH: C:\USERS\JENGLESO\DOCUMENTS\PROJECTS\VISTA\_IRRIGATION\_DISTRICT\2016\_WATER\_MASTER\_PLAN\_UPDATE\_10043046\INFOWATER\VID\_ULTIMATE\_PHD\_DEFICIENCIES.MXD - USER: JENGLESO - DATE: 1/16/2018



*This page is intentionally blank.*

Figure 8-2. Ultimate System Minimum Day Demand Pressures

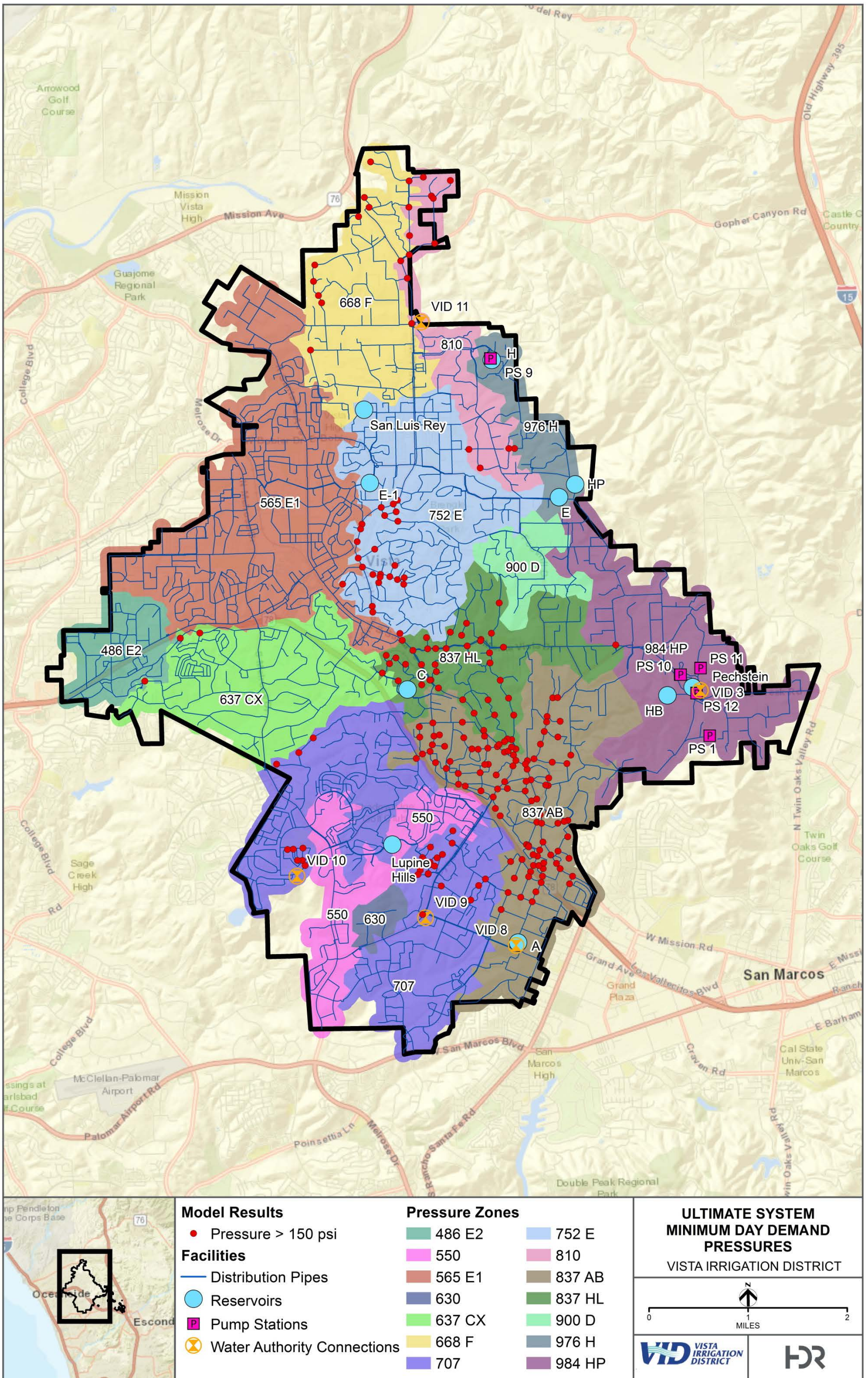

PATH: C:\USERS\JENGLESO\DOCUMENTS\DOCUMENTS\PROJECTS\VISTA\_IRRIGATION\_DISTRICT\2016\_WATER\_MASTER\_PLAN\_UPDATE\_10043046\INFOWATER\VID\_ULTIMATE\_MINDD\_DEFICIENCIES.MXD - USER: JENGLESO - DATE: 1/16/2018



*This page is intentionally blank.*

## 8.2 Recommended Ultimate System Improvements

The recommended ultimate system improvements are summarized in **Table 8-2**. **Figure 8-3** shows the locations of the improvements in the distribution system. Improvements were identified based on analysis with the InfoWater hydraulic model and the evaluation criteria discussed in **Chapter 5**.

Ultimate system model runs were developed using the existing system infrastructure, plus the recommended existing system improvement projects discussed in **Chapter 7**, run with ultimate demands. Recommended ultimate system improvement projects are limited to one project addressing high velocities in pipes in the 565 zone. This project is described in more detail in the paragraph below. Further discussion on alternative strategies to increase the District’s ability to move water from VID 9 and VID 11 to Pechstein Reservoir in the event of outages of the Vista Flume and/or VID 3 is also provided.

**Table 8-2. Recommended Ultimate System Improvements**

Project Number	Description	Diameter (Inches)	Length (Feet)	Reason
ULT-1	Installation of 10-inch diameter interconnection between 8-inch and 12-inch parallel pipes in Olive Avenue at the intersection of Grapevine Road	10	30	High velocities in pipes in Olive Avenue

### 8.2.1 High Velocity Pipes in Olive Ave (ULT-1)

The 565 zone has the largest total demand in the existing and ultimate systems. As a result, this zone can experience high local flows and associated high velocities. Model results indicate that one reach of 8-inch pipe in Olive Avenue, from Grapevine Road to Burke Road, may experience velocities exceeding the evaluation criteria under PHD conditions. This reach of 8-inch pipe is paralleled by a reach of pipe varying in diameter from 10 to 12 inches.

Project ULT-1 is recommended to alleviate the high velocities in the 8-inch pipe. ULT-1 consists of installing a 10-inch interconnection between existing parallel pipes in Olive Avenue at the intersection of Grapevine Road. Additionally, it is recommended that existing interconnections between parallel pipes in Olive Avenue at the intersection of Brookings Lane be open to allow flow in all directions. Model results indicate that these changes would allow parallel flow within the existing parallel pipes in Olive Avenue reducing the velocity in the 8-inch pipe to an acceptable level. Project ULT-1 is displayed in **Figure 8-3**.

*This page is intentionally blank.*

Figure 8-3. Recommended Ultimate System Improvements

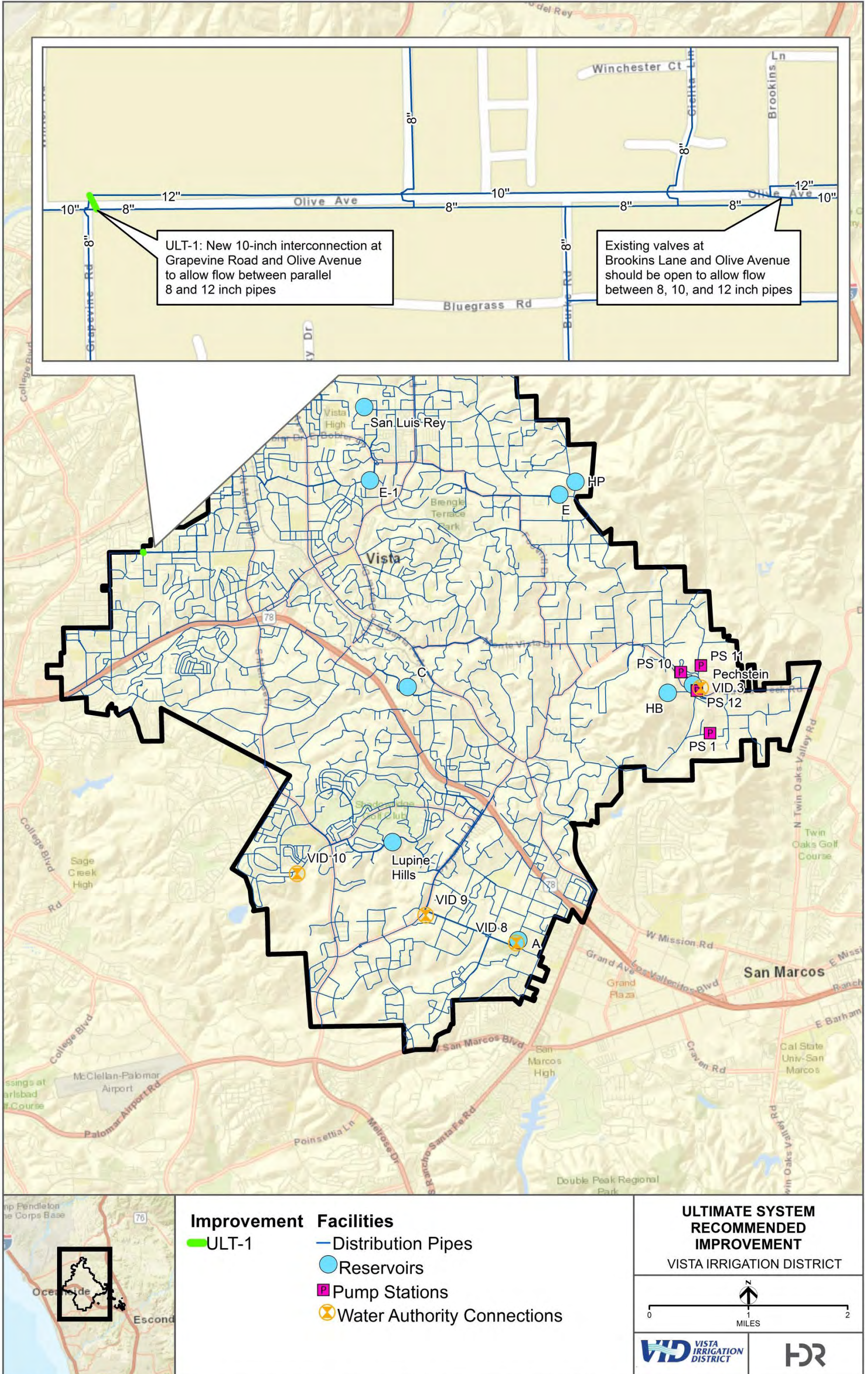

PATH: C:\USERS\JENGLES\DOCUMENTS\DOCUMENTS\PROJECTS\VISTA\_IRRIGATION\_DISTRICT\2016\_WATER\_MASTER\_PLAN\_UPDATE\_10043046\INFOWATER\VID\_ULTIMATE\_CIP\_PARALLEL.MXD - USER: JENGLES - DATE: 1/16/2018



*This page is intentionally blank.*

### 8.2.3 Redundant Water Supply Strategies

Water reliability improvement concepts were discussed in **Section 4.5**, including providing redundancy to VID 3 connection in conjunction with a long-term outage of the Vista Flume. A hydraulic model analysis was conducted for this scenario. The goal of this exercise was to find a way to convey water from both VID 9 and VID 11 to Pechstein, relying as much as possible on existing infrastructure, and satisfying evaluation criteria. The benefit of the District's ability to convey water from VID 9 and/or VID 11 to Pechstein is increased operational flexibility and the ability to operate the system using existing Water Authority connections in the event the Vista Flume and VID 3 are both offline.

The base scenario in this redundant alternatives analysis included existing infrastructure, plus existing and ultimate recommended improvement projects, and ultimate demands. MDDs were used to represent the system operating at full capacity. This represents a worst case condition, and the District may wish to evaluate facility requirements further under average or winter demand conditions. Both the VID 9 and VID 11 redundant supply concepts were included in a single scenario. **Figure 8-4** illustrates the location of facilities relevant to the redundant supply concepts.

#### Vista Irrigation District 9 Supply Strategy

The VID 9 redundant supply concept consists of extending an existing large diameter pipe from the VID 9 connection north along Sycamore Avenue and along Buena Creek Road. Currently, an existing 20-inch pipe extends from VID 9 northeast to the BCS PRS near the intersection of Sycamore Avenue and Highway 78. Approximately 6,600 feet of new 20-inch pipe would need to be added to extend the pipeline to its terminus at the intersection of Buena Creek Road and Canyon Drive. Additionally, with the exception of two existing turnoffs to PRS feeding the 707 zone (VID 9 PRS and BCS PRS), the large diameter pipeline would not connect to the distribution system until it reaches its new terminus at the intersection of Buena Creek Road and Canyon Drive. Currently, at least two connections from the existing 20-inch pipe to the existing 837 distribution system would need to be closed to isolate the flows. Isolating the pipeline would allow flow from VID 9 to enter the 837 zone nearer the Pechstein Reservoir.

The strategy for the VID 9 redundant supply concept is to avoid high distribution system pressures by introducing the flow at a relatively high elevation near the Pechstein Reservoir. This approach (1) decreases the pressure head at the point the flow is introduced to the distribution system, and (2) takes advantage of headloss across the 837 zone to decrease pressures in lower elevation areas of the zone. The VID 9 connection can be supplied by a total head value near 1,000 feet. By conveying the VID 9 flows to the elevation of 510 feet at the intersection of Buena Creek Road and Canyon Drive, the change in elevation head, minus headloss in the transmission main, bring the effective pressure below 170 psi at this location under ultimate MDD conditions.

On the other hand, the 837 zone is designed for water to feed the zone from Pechstein Reservoir. As the system is currently operated, headlosses across the distribution system decrease total head as water flows downhill from Pechstein. The result is a balance between headloss gradient and elevation head gradient that results in pressure head that is acceptable, although relatively high, at the lower elevations of the pressure

zone. Introducing VID 9 flows nearer Pechstein Reservoir takes advantage of this system design, and allows the increased head due to larger VID 9 inflow to be decreased by the headloss gradient across the distribution system to the lower elevation areas of the zone.

### Vista Irrigation District 11 Supply Strategy

The overall VID 11 supply strategy is to convey water from VID 11 to the higher elevation zones of the District's distribution system, specifically to Pechstein, in order to facilitate typical system operation in the case that the Vista Flume and VID 3 are offline. For the purposes of this Master Plan study, both the VID 9 and VID 11 supply strategies are assumed to be operational concurrently.

An E Reservoir PS was included in the existing improvements project list in **Chapter 7**. E Reservoir is located at the intersection of four major pressure zones: the 752, 810, 837, and 976/984. An E Reservoir PS (752 zone) could conceivably provide flow to any of the four higher zones in the immediate area. Because the distribution system was not designed to pump flows from E Reservoir to these adjacent zones, existing hydraulic capacity in the respective zones may not be sufficient to handle significant flows in a reversed direction from an E Reservoir PS.

The VID 11 redundant supply concept consists of pumping flows from the E Reservoir to the 976/984 zone in order to fill the Pechstein Reservoir. The VID 11 Water Authority connection currently has a capacity of 50 cfs. In the current distribution system, VID 11 flows are split between the 668, 752, and 810 zones. Flows to the 810 zone are primarily fed into the H Reservoir. Flows to the 668 zone are reduced at PRSs and conveyed to lower zones. Flows to the 752 zone are reduced at the E30S PRS and conveyed to the E Reservoir via recently installed large diameter pipe ranging from 30 to 24 inches in diameter.

For the purposes of the VID 11 redundant supply strategy, this large diameter feed from E30S to the E Reservoir would be converted to an isolated, dedicated pipeline conveying flows to the E Reservoir at a pressure higher than the surrounding 752 distribution system. The pipeline would connect to the existing distribution system at Bobier Drive and Vista Way in order to convey flows to the E32 PRS. Additionally, the pipeline would connect to the distribution system at Foothill Drive and Edgehill Road in order to convey flows to the 752 zone. The existing E30S PRS would be adjusted from a setting of 102-103 psi to 132-133 psi to increase the head in the dedicated pipeline and provide increased flow to the E Reservoir.

The new E Reservoir PS would convey flow from the E Reservoir directly to the 976/984 zone. The 976/984 zone would be isolated from the adjacent zones near the E Reservoir, so that flows from the E Reservoir PS are conveyed to the HB Reservoir. The 976/984 zone would be supplied by the HP Reservoir and existing PS 9 from the H Reservoir, which is fed by VID 11. Flows from the E Reservoir PS to the HB Reservoir would be used to fill the Pechstein Reservoir via either an updated HP relief valve or a new PRS designed to regulate flows to the Pechstein Reservoir from the 976/984 zone.

The strategy for conveying flows from the E Reservoir to the 976/984 zone is to avoid the high pressure issues resulting from pumping flow directly into the 837 zone at the E Reservoir location. By conveying flow to the 976/984 zone, pressures in the 837 zone are not affected and Pechstein can be filled from the higher zone.

Figure 8-4. Redundant Water Authority Supply to 837 and 976/984 Zones

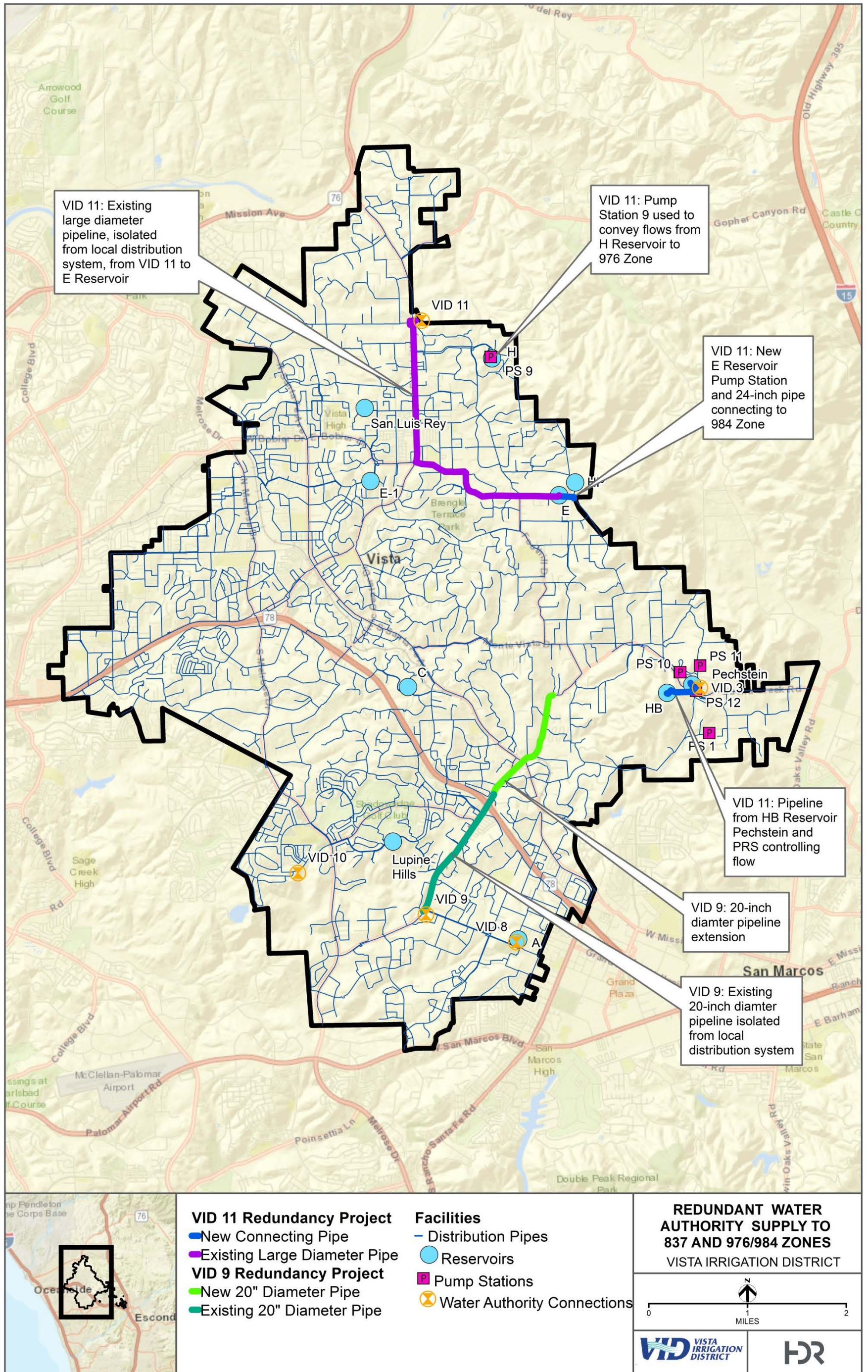

PATH: C:\USERS\JENGLES\DOCUMENTS\DOCUMENTS\PROJECTS\VISTA\_IRRIGATION\_DISTRICT\2016\_WATER\_MASTER\_PLAN\_UPDATE\_10043046\INFOWATER\VID\_ULTIMATE\_REDUNDANT\_CIP.MXD - USER: JENGLESO - DATE: 1/16/2018



*This page is intentionally blank.*

## Resulting System Deficiencies

Implementing the VID 9 and VID 11 redundant water supply alternatives results in acceptable operating pressures but also creates pipe velocities above the evaluation criteria of 8 fps under ultimate PHD conditions. Further study is required to assess specific demand conditions and mitigation measures that could alleviate these high velocities. Pipes experiencing high velocities include the following.

- 18-inch diameter pipe in Edgehill Road
- 20-inch diameter pipe Mango Glen to Catalina Heights Way
- Various pipes in Buena Creek Road
- 14-inch feed into HB Reservoir

## 8.3 Storage Assessment

The required reservoir storage based on ultimate system demands and the storage criteria defined in **Chapter 4** is presented in **Table 8-3**. The storage assessment is based on ultimate demands and storage for each zone. Projected ultimate demands were estimated using the methodology discussed in **Chapter 3** and allocated to pressure zones based on land use type. It was also assumed that zones with excess capacity would supplement storage deficiencies in other zones. As with the existing storage assessment discussed in **Chapter 7**, the ultimate system storage assessment presented in **Table 8-3** does not account for storage required during Water Authority aqueduct shutdowns.

Based on the required storage calculations, the ultimate system is projected to have a storage deficit of 3.88 MG. As with the existing system storage assessment, the 707, 637, 752, and 565 zones are projected to have insufficient storage based on projected demands. The remaining zones have excess capacity, notably the 837 zone has significant excess storage capacity in Pechstein Reservoir.

The 2000 Master Plan recommended the construction of a 20 MG Pechstein II Reservoir to address the projected ultimate system deficiency and additional emergency storage. The proposed Pechstein II location, adjacent to the existing Pechstein Reservoir location, is advantageous based on the availability of District owned land to accommodate such a large reservoir, and its elevation. This would also allow the District to take the existing Pechstein Reservoir off line for rehabilitation. Additional storage serving the 837/810 zone would provide flows to all the lower zones projected to have storage deficiencies in the ultimate system. Any additional storage would need to have an operational capacity of at least 3.88 MG in order to offset the projected ultimate system storage deficiency.

Reservoir E is being considered for near term replacement. In 1995, the proposed replacement project consisted of a 146-diameter, 38-foot-high, 4.4 MG prestressed concrete reservoir, as discussed in **Chapter 4**. This reservoir would enhance emergency supply within the E zone, which requires 4.98 MG in the ultimate system. However, this site is significantly constrained by neighboring residences and sensitive habitat. Alternatively, the District's total storage deficit would be offset with the addition of a Pechstein II Reservoir project.

**Table 8-3. Ultimate System Storage**

Major Pressure Zone	Zone Grade (Feet)	AAD <sup>1</sup>		MDD <sup>2</sup> (MGD)	Storage Criteria <sup>3</sup>						Reservoir	Existing Operational Storage (MG)	Surplus (Deficit) (MG)
		(gpm)	(MGD)		Operational (Gallons) +	Fire (Gallons)	or	Emergency (Gallons)	=	Total (MG)			
HB Zone	984, 900	1,233	1.78	3.55	355,029	300,000		3,550,286		3.91	HB	4.05	0.14
HP Zone	976	212	0.31	0.61	61,098	300,000		610,980		0.67	HP	4.30 <sup>4</sup>	3.63
AB/HL Zone	837	2,770	3.99	7.98	797,722	540,000		7,977,218		8.77	Pechstein	18.50	9.73
810, F Zone	810, 668	1,136	1.64	3.27	327,179	540,000		3,271,790		3.60	H	5.00	1.40
707 Zone	707, 630	1,890	2.72	5.44	544,197	735,000		5,441,972		5.99	A	0.60	(5.39)
CX Zone	637	1,237	1.78	3.56	356,209	540,000		3,562,086		3.92	C	0.60	(3.32)
E Zone	752	1,571	2.26	4.52	452,444	540,000		4,524,438		4.98	E	1.20	(3.78)
550 Zone	550	711	1.02	2.05	204,855	735,000		2,048,550		2.25	LH	3.00	0.75
E-1, E-2 Zone	565, 486	3,154	4.54	9.08	908,438	735,000		9,084,379		9.99	SLR, E1	3.20	(6.79)
Totals		13,914	20.04	40.07	4,007,170	4,965,000		40,071,700		44.08		40.45	(3.63)

<sup>1</sup> Buildout demands based on SANDAG Series 13 Planned Land Use and Unit Demand Factors rounded up to the nearest 50. Projected demands represent increased demand density compared with existing demands.

<sup>2</sup> MDD = 2 x ADD

<sup>3</sup> Total = Operational + larger of Fire or Emergency Storage Criteria'

Operational = 0.1 x MDD

Fire = Fire flow and duration per requirements in **Table 4-3**, including 2,500 gpm for 2 hours (300,000 gallons) in wild fire interface areas.

Emergency = 2 x AAD

<sup>4</sup> HP Reservoir volume, as rehabilitated in 2017.

AAD – average annual demand; MDD – maximum day demand; gpm - gallons per minute; MG – million gallons; MGD – million gallons per day



**Agenda Item: 7**

**STAFF REPORT**

**Board Meeting Date: January 30, 2018**  
**Prepared By: Lisa Soto**

SUBJECT: COMMENTS BY DIRECTORS

SUMMARY: This item is placed on the agenda to enable individual Board members to convey information to the Board and the public not requiring discussion or action.



**Agenda Item: 8**

**STAFF REPORT**

**Board Meeting Date: January 30, 2018**  
**Prepared By: Eldon Boone**

SUBJECT: COMMENTS BY GENERAL MANAGER

SUMMARY: Informational report by the General Manager on items not requiring discussion or action.