



STANDARD DRAWINGS

**Vista Irrigation District
1391 Engineer Street, Vista, CA 92081-8840
(760) 597-3100**

Engineering Department - (760) 597-3116 / Fax: (760) 597-2632
Construction Inspector – (760) 597-3126

SECTION 09000 - STANDARD DRAWINGS

DWG SECTION 1 - WATER METERS  , BACKFLOW DEVICES

- 1-1 1" WATER SERVICE (03/16/16)
- 1-1A EXISTING WATER SERVICE ABANDONMENT (04/02/13)
- 1-2 2" WATER SERVICE (03/16/16)
- 1-3 COMBINATION DOMESTIC IRRIGATION SERVICE FOR COMMERCIAL/INDUSTRIAL LOTS (03/25/11)
- 1-4 METER BOX LOCATIONS (03/25/11)
- 1-5 "NOT USED"
- 1-6 CONCRETE METER BOX IN PAVED ROADWAY (12/02/99)
- 1-7 RP INSTALLATION 2" & SMALLER (03/25/11)
- 1-8 RP INSTALLATION 3" AND LARGER (01/25/17)
- 1-9 3" & LARGER AGRICULTURAL METER (01/24/17)
- 1-10 TURBINE METER & VAULT (2" X 4") & 6" ASSEMBLIES (09/26/03)
- 1-10A PEDESTRIAN LOADING HATCH COVER FOR METER VAULTS (09/26/03)
- 1-11 SUBDIVISION CONSTRUCTION METER ASSEMBLY (03/16/16)
- 1-12 WATER QUALITY SAMPLING STATION (12/02/99)

DWG SECTION 2 - AIR RELEASES 

- 2-1 1" & 2" MANUAL AIR RELEASES (TYPE A) (12/02/99)
- 2-2 1" & 2" MANUAL AIR RELEASES (TYPE B) (03/16/16)
- 2-2A 2" MANUAL AIR RELEASE/BLOW OFF (03/16/16)
- 2-3 2" AUTOMATIC COMBINATION AIR RELEASE & AIR/VACUUM VALVE INSTALLATIONS (03/16/16)
- 2-4 4" & 6" AUTOMATIC COMBINATION AIR RELEASE & AIR/VACUUM VALVES INSTALLATIONS (03/16/16)
- 2-5 AIR & VACUUM VALVE ENCLOSURES (04/12/12)
- 2-6 AIR & VACUUM VALVE ENCLOSURE LOCATIONS (04/12/12)

DWG SECTION 3 - BLOW-OFFS 

- 3-1 2" BLOW-OFF ASSEMBLY TYPE 1 & 2 (03/16/16)
- 3-2 2" BLOW-OFF ASSEMBLIES TYPES B & C (03/25/11)
- 3-3 4" & 6" BLOW-OFF ASSEMBLY TYPE A (06/06/14)
- 3-4 4" & 6" BLOW-OFF ASSEMBLIES TYPE B (12/02/99)

DWG SECTION 4 - FIRE HYDRANTS 

- 4-1 6" FIRE HYDRANT ASSEMBLY (03/16/16)
- 4-2 FIRE HYDRANT LOCATIONS (12/10/12)
- 4-3 PROTECTION POST (12/02/99)
- 4-4 FIRE SERVICE CONNECTIONS (12/02/99)
- 4-5 REDUCED PRESSURE DETECTOR ASSEMBLY 3" OR LARGER (03/25/11)

DWG SECTION 5 - PIPELINES & THRUST BLOCKS

- 5-1 STANDARD EASEMENT WIDTHS (12/02/99)
- 5-2 PIPE BEDDING & TRENCH BACKFILL FOR WATER MAINS (03/25/11)
- 5-3 VALVE WELL INSTALLATION (03/25/11)
- 5-4 VALVE STEM EXTENSION (12/02/99)
- 5-5 CONCRETE VALVE BLOCKING (04/11/13)
- 5-6 ANCHOR BLOCK (VERTICAL BEND ONLY) (12/02/99)
- 5-7 CONCRETE THRUST BLOCKS (12/02/99)
- 5-8 THRUST BLOCK BEARING AREAS (12/02/99)
- 5-9 VALVE SIZING FOR STEEL MAINS (12/02/99)

DWG SECTION 6 - STEEL PIPES

- 6-1 STEEL WATER PIPE ELBOW DESIGNS (12/02/99)
- 6-2 STANDARD CROSSING (UNDER PROPOSED OBJECT) (12/02/99)
- 6-3 STANDARD CROSSING (ABOVE PROPOSED OBJECT) (12/02/99)
- 6-4 PRESSURE REDUCTION STATION (12/02/99)

DWG SECTION 7 - SEWER/WATER SEPARATIONS

- 7-1 WATERLINE & SEWER LINE SEPARATIONS (12/02/99)
- 7-2 WATERLINE & SEWER LINE SEPARATIONS (12/02/99)
- 7-3 WATERLINE & SEWER LINE SEPARATIONS (12/02/99)
- 7-4 WATERLINE & SEWER LINE SEPARATIONS (12/02/99)
- 7-5 WATERLINE & SEWER LINE SEPARATIONS (12/02/99)
- 7-6 WATERLINE & SEWER LINE SEPARATIONS (12/02/99)
- 7-7 VISTA FLUME & SEWER SEPARATIONS (12/02/99)

DWG SECTION 8 - CATHODIC PROTECTION

- 8-1 PREPACKED MAGNESIUM ANODE (12/02/99)
- 8-2 PREPACKED ZINC ANODE (12/02/99)
- 8-3 PREPACKED COPPER SULFATE REFERENCED ELECTRODE (12/02/99)
- 8-4 POST MOUNTED ANODE TEST BOX (12/02/99)
- 8-5 WIRING DIAGRAMS INSULATOR TEST BOXES (12/02/99)
- 8-6 TWO-WIRE TEST BOXES (12/02/99)
- 8-7 WIRING DIAGRAM TWO-WIRE TEST BOXES (12/02/99)
- 8-8 CASING TEST BOXES INSTALLATION (12/02/99)
- 8-9 WIRING DIAGRAMS CASING TEST BOXES (12/02/99)
- 8-10 INSULATING FLANGE ASSEMBLY (12/02/99)
- 8-11 INSULATING FLANGE COATING (12/02/99)
- 8-12 INSULATING BLANKET (12/02/99)
- 8-13 ANODE & TEST BOX INSTALLATION (12/02/99)
- 8-14 ZINC ANODE INSTALLATION FOR COPPER LATERALS (12/02/99)
- 8-15 ALUMINO-THERMIC WELD (12/02/99)

8-16	JOINT BONDING (12/02/99)
8-17	BONDING CONFIGURATION FOR SPECIALS (12/02/99)
8-18	JOINT BOND REPAIR (12/02/99)
8-19	AT-GRADE TEST BOX (12/02/99)
8-20	AT-GRADE YARD BOX (12/02/99)
8-21	AT-GRADE ANODE TEST BOXES (12/02/99)
8-22	MAGNESIUM ANODE TABLES FOR STEEL MAINS (12/02/99)

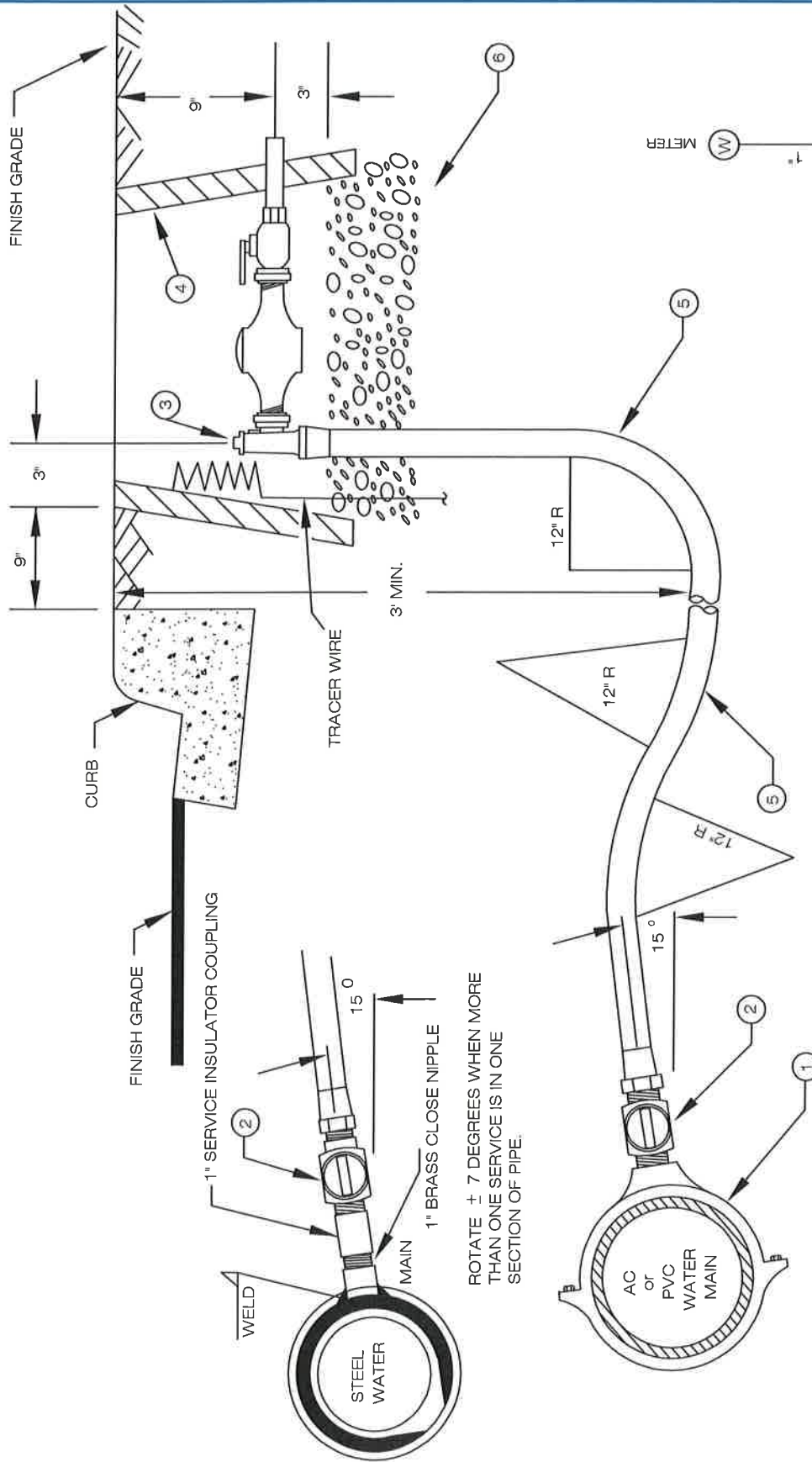

NOTES

LEGEND ON PLANS

- A) INSTALL CATHODIC PROTECTION PER STD. DWG. 8-14
- B) ALL WATER METER OUTLETS SHALL BE LOCATED WITHIN LANDSCAPED AREAS. PLACEMENT OF OUTLETS IN PAVED AREAS REQUIRE PRIOR APPROVAL & SHALL BE IDENTIFIED ON THE IMPROVEMENT PLANS WITH THE SYMBOL *
- C) INSTALL WARNING IDENTIFICATION TAPE

- ① SIZE X 1" SERVICE SADDLE
- ② 1" BRONZE CORPORATION STOP
- ③ 1" BRONZE ANGLE METER STOP WITH LOCKWORK
- ④ METER BOX (SEE STD. DWG. 1-4 FOR LOCATION) METER BOX LOCATED IN TRAVELED WAYS, PAVED AREAS, AND SIDEWALKS SHALL BE SELECTED FROM THE APPROVED MATERIAL LIST.
- ⑤ USE TYPE "K" COPPER TUBING FOR 1" SERVICE. (NO INTERMEDIATE JOINTS PERMITTED)
- ⑥ 3/8" ROCK (4" TO 6") DEEP

ROTATE ± 7 DEGREES WHEN MORE THAN ONE SERVICE IS IN ONE SECTION OF PIPE.

REVISIONS	APPROVED	DATE
UPDATED	B. SMITH	03/25/11
UPDATED	B. SMITH	04/11/13

VISTA IRRIGATION DISTRICT

1" WATER SERVICE

Brian Smith 3/16/16
 BRIAN SMITH DATE
 R.C.E. 39926

STD. DWG. 1-1

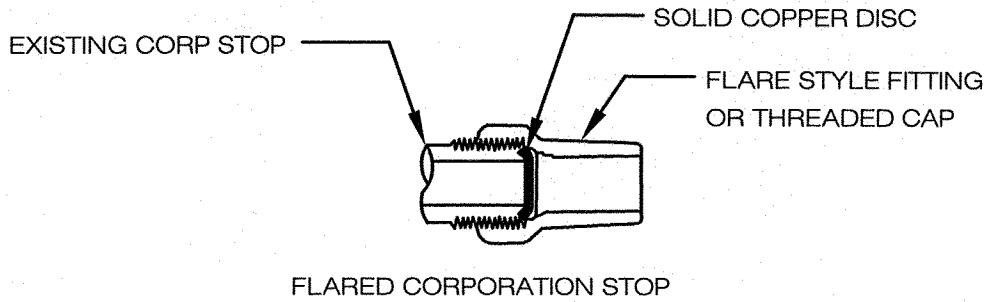

PLUG AND CAP DETAIL

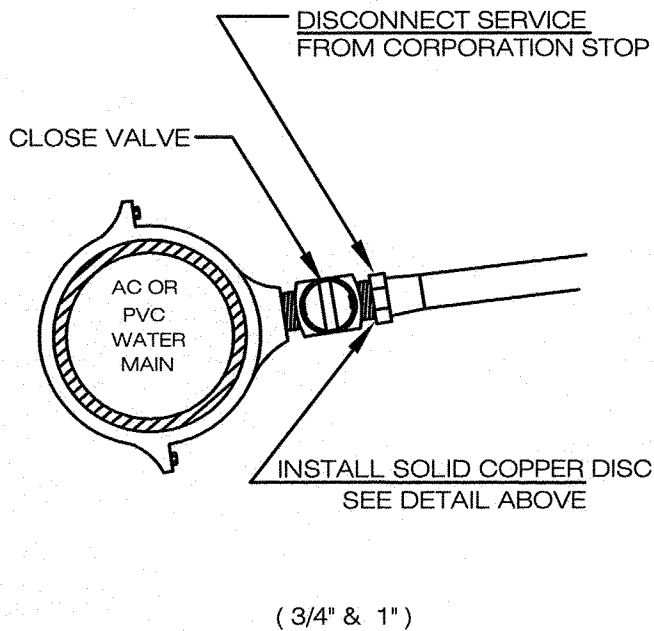

SERVICE CONNECTION

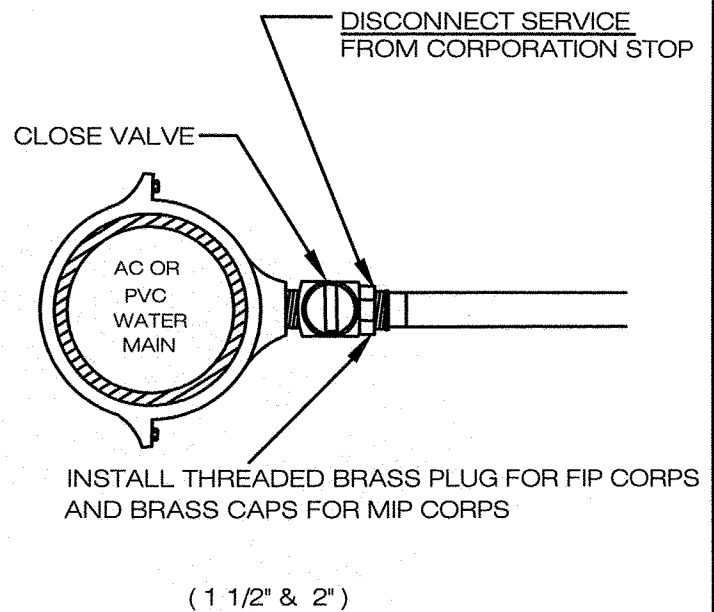

SERVICE CONNECTION

NOTES:

- ① IF WATERLINE IS SHUTDOWN, REMOVE CORP AND INSTALL BRASS PLUG
- ② REMOVE A 2' SECTION FROM THE CORP TO THE ABANDONED PIECE AND CRIMP THE END OF THE ABANDONED COPPER
- ③ IF THE CORP IS A DIRECT TAP, CORP WILL NEED TO BE REMOVED AND AN APPROVED SADDLE AND PLUG WILL NEED TO BE INSTALLED

/ / / / /

LEGEND ON PLANS

REVISIONS	APPROVED	DATE	VISTA IRRIGATION DISTRICT	
			EXISTING WATER SERVICE ABANDONMENT	<i>Brian Smith</i> 4/2/13
				BRIAN SMITH DATE
				R.C.E. 39926
				STD. DWG. 1-1A

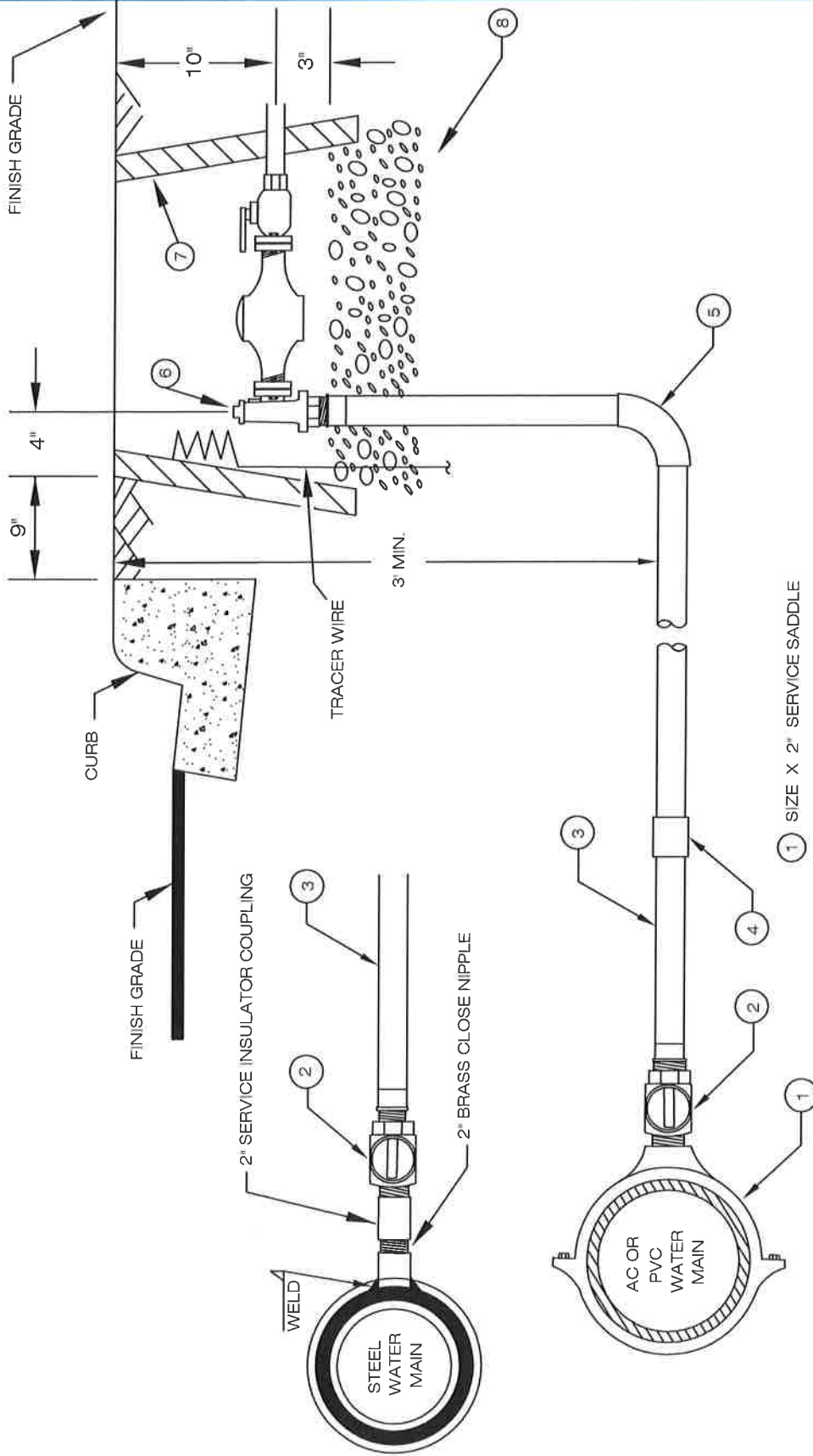

NOTES

- A) INSTALL CATHODIC PROTECTION PER STD. DWG. 8-14
 - B) ALL WATER METER OUTLETS SHALL BE LOCATED WITHIN LANDSCAPED AREAS. PLACEMENT OF OUTLETS IN PAVED AREAS REQUIRE PRIOR APPROVAL AND SHALL BE IDENTIFIED ON THE IMPROVEMENT PLANS WITH THE SYMBOL ★
 - C) INSTALL WARNING IDENTIFICATION TAPE
 - D) SILVER SOLDER JOINTS REQUIRED
- 1 SIZE X 2" SERVICE SADDLE
 - 2 2" BRONZE CORPORATION STOP
 - 3 2" COPPER TUBING-TYPE "K"
 - 4 2" COUPLING AS REQUIRED WHEN SERVICE IS 20' OR LONGER
 - 5 2" COPPER 90 DEGREE ELL
 - 6 2" BRONZE ANGLE METER STOP WITH LOCKING
 - 7 METER BOX (SEE STD. DWG. 1-4 FOR LOCATION)
METER BOX LOCATED IN TRAVELED WAYS, PAVED AREAS AND SIDEWALKS SHALL BE SELECTED FROM THE APPROVED MATERIAL LIST.
 - 8 3/8" ROCK (4" TO 6") DEEP

REVISIONS	APPROVED	DATE
UPDATED	B. SMITH	03/25/11
UPDATED	B. SMITH	04/11/13

VISTA IRRIGATION DISTRICT

2" WATER SERVICE

Brian Smith 3/16/16
BRIAN SMITH **DATE**
 R.C.E. 39926

STD. DWG. 1-2

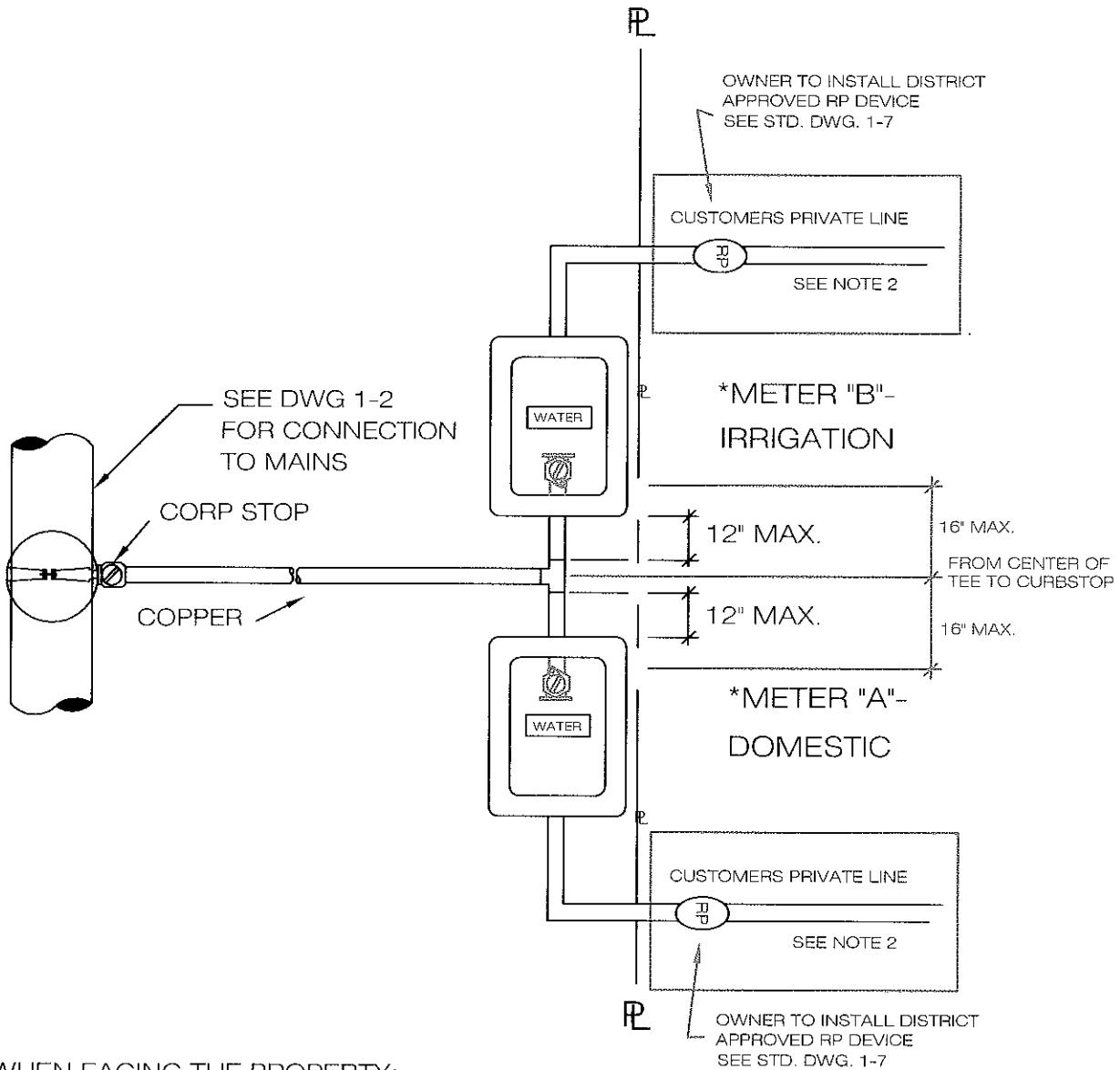

* WHEN FACING THE PROPERTY:

METER "A" (DOMESTIC METER) SHALL BE PLACED ON THE RIGHT
 METER "B" (IRRIGATION METER) SHALL BE PLACED ON THE LEFT

NOTES:

1. TO BE USED FOR INDUSTRIAL AND COMMERCIAL LOTS ONLY
2. SIZE TO BE DETERMINED BY SIZE OF WATER METERS
3. FOR METER BOX LOCATIONS AND INSTALLATION SEE DRAWINGS 1-2 AND 1-4.
4. INSTALL CATHODIC PROTECTION PER STD. DWG. 8-14
5. REQUIRED LOCATION OF RP DEVICE. ALTERNATE LOCATION REQUIRES APPROVAL OF V.I.D. WATER QUALITY INSPECTOR.

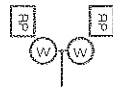

LEGEND ON PLANS

REVISIONS	APPROVED	DATE	VISTA IRRIGATION DISTRICT	
UPDATED	B. SMITH	03/25/11	COMBINATION DOMESTIC-IRRIGATION SERVICE FOR COMMERCIAL / INDUSTRIAL LOTS	 3/25/11 BRIAN SMITH DATE R.C.E. 39926

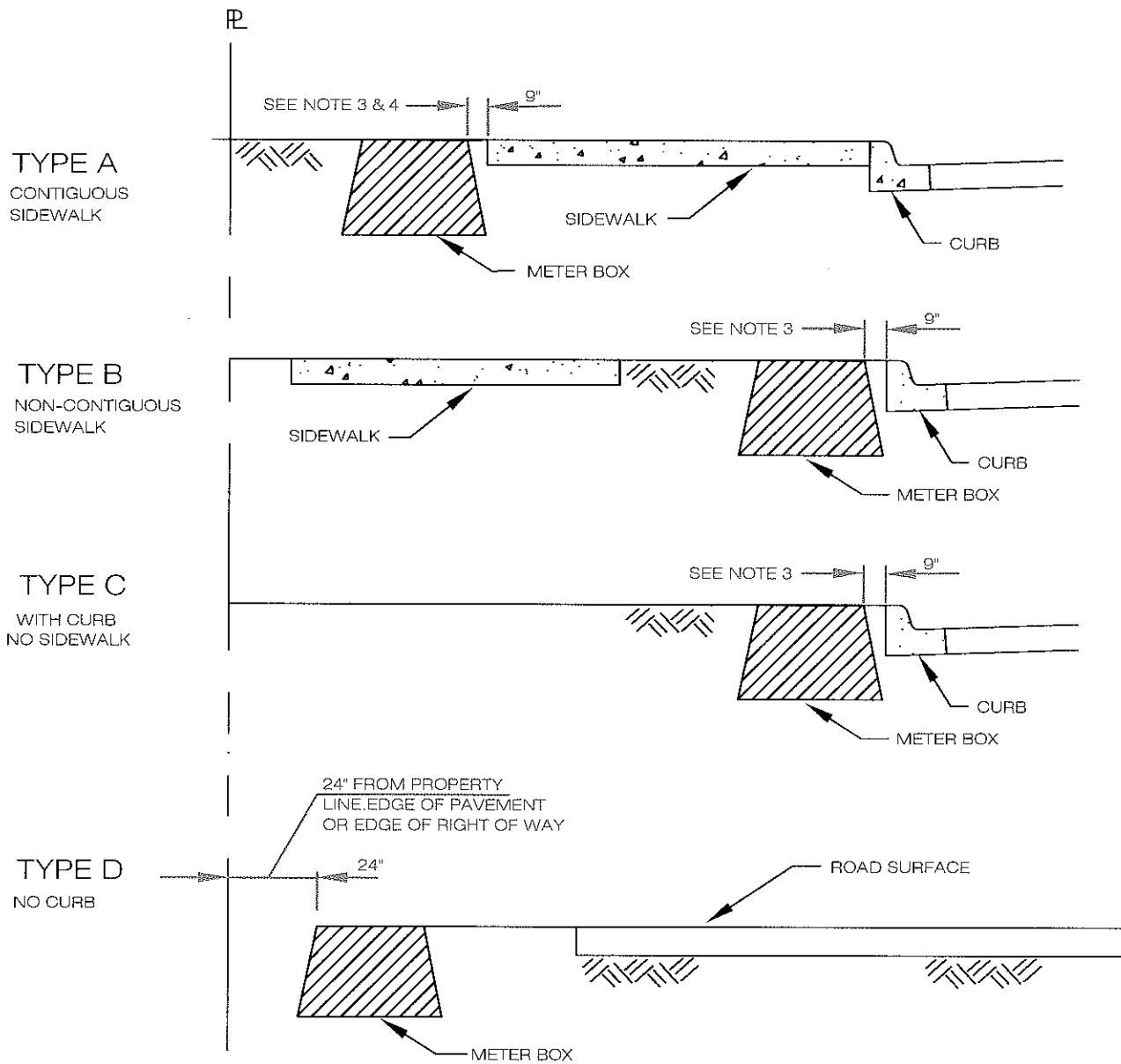

NOTE:

1. METER BOXES SHALL NOT BE LOCATED IN DRIVEWAYS.
2. WHERE SERVICE LATERAL CROSSES A NEW CURB, THE LOCATION SHALL BE MARKED BY STAMPING A "W" IN THE FACE OF THE CURB AT THE CROSSING POINT.
3. METER BOX SHALL BE INSTALLED 9" FROM BACK OF BERM, CURB, OR SIDEWALK.
4. AN EASEMENT MAY BE NEEDED DEPENDING ON LOCATION OF METER BOX.

REVISIONS	APPROVED	DATE	VISTA IRRIGATION DISTRICT
UPDATED	B. SMITH	03/25/11	METER BOX LOCATIONS
			<i>Brian Smith</i> 3/25/11 BRIAN SMITH DATE R.C.E. 39926
			STD. DWG. 1-4

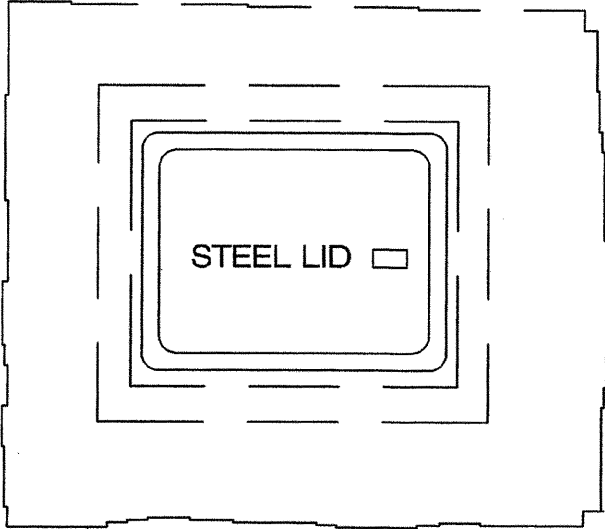

METER SIZE	A	B	C
3/4" x 1" & 1"	12"	25"	20"
1 1/2"	12"	30"	24"
2"	12"	42"	29"

NOTE: THIS INSTALLATION ALLOWED ONLY UPON WRITTEN PERMISSION BY DISTRICT. REF. STD. DWGS. 1-1 & 1-2

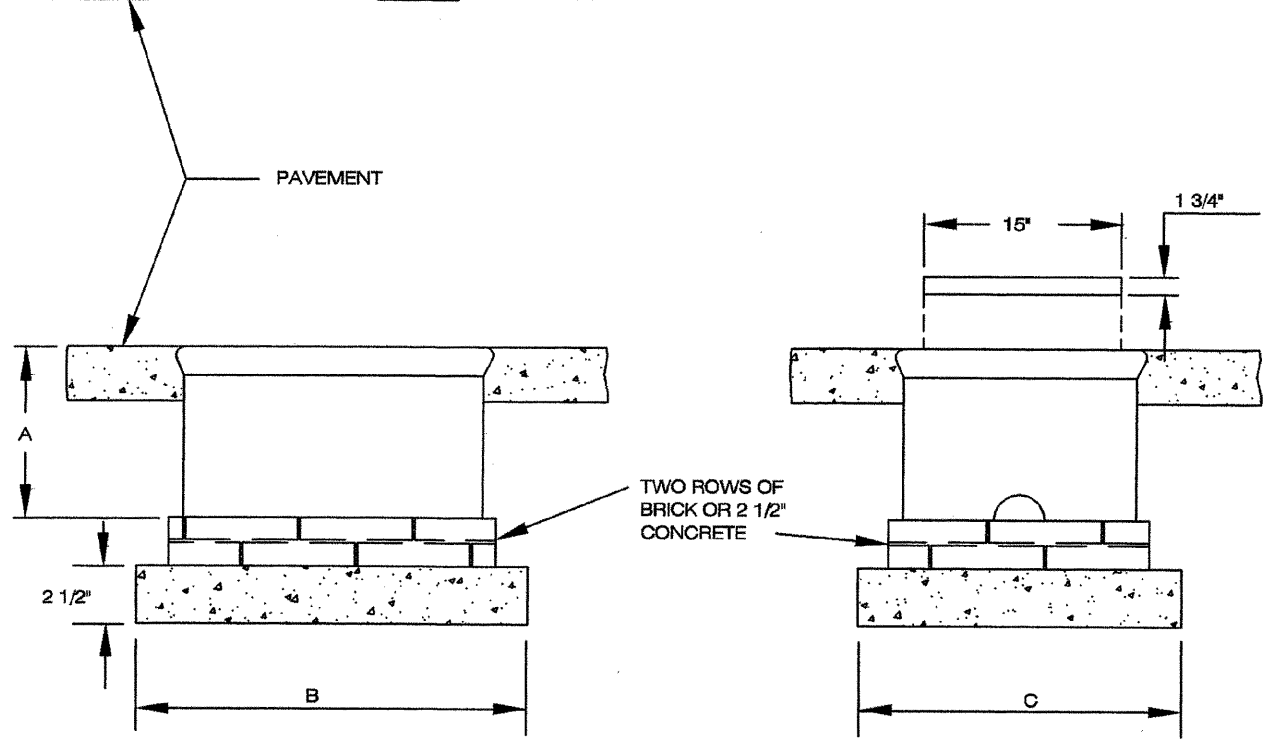

USED ONLY UPON WRITTEN APPROVAL OF DISTRICT

REVISIONS	APPROVED	DATE	VISTA IRRIGATION DISTRICT	PATH: (TOM) H:\STDDWGS\1-6.DWG
			CONCRETE METER BOX IN PAVED ROADWAY	 JOHN AMODEO R. C. E. 31161
				DATE
				STANDARD DRAWING 1-6
ACAD		6/96		

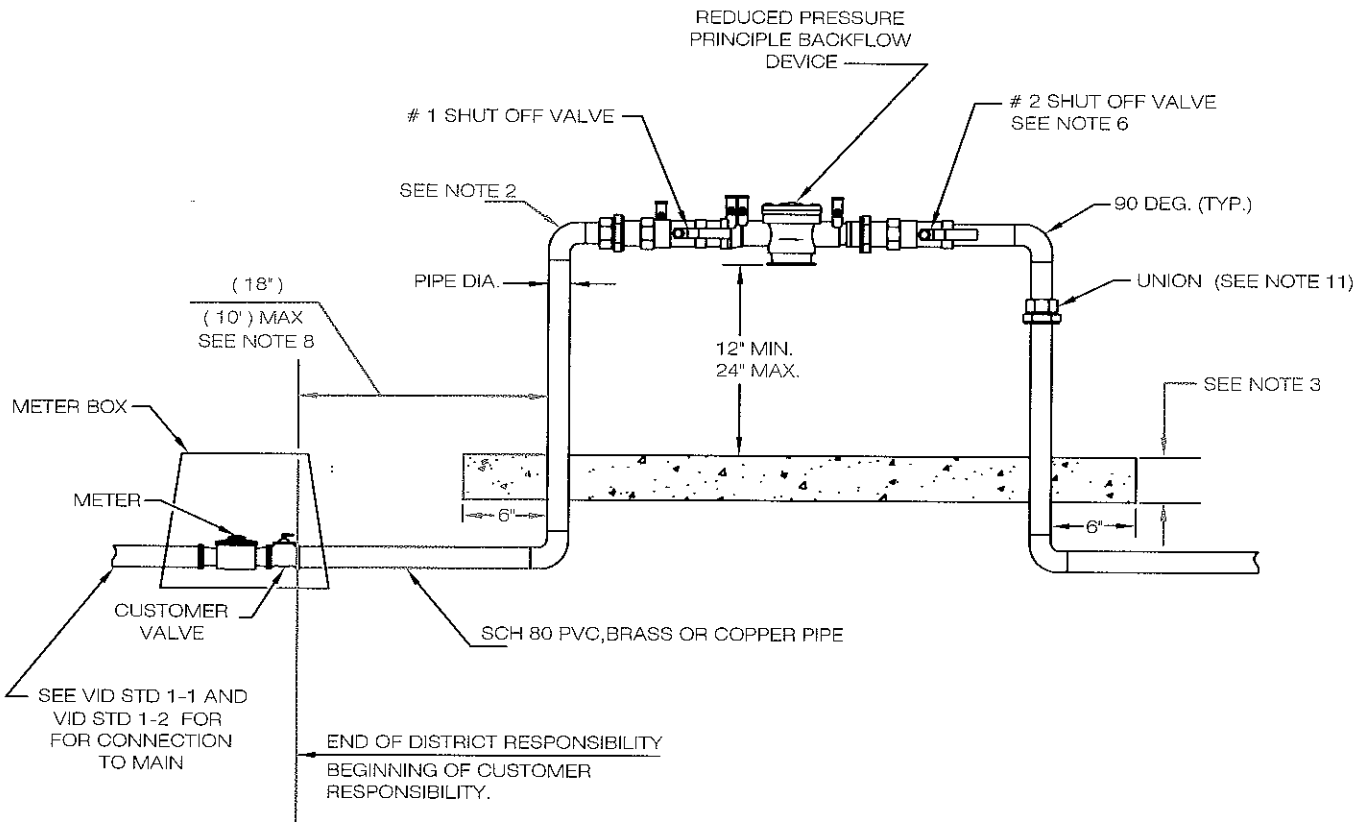

NOTES

1. BACKFLOW PREVENTER ASSEMBLY SHALL BE TESTED AND INSPECTED BY THE DISTRICT BEFORE WATER SERVICE IS ESTABLISHED.
2. ALL ABOVE GROUND PIPING, UNIONS, ELBOWS, & NIPPLES SHALL BE TYPE "K" OR "L" SOLDERED COPPER OR THREADED BRASS.
3. CONCRETE PAD SHALL BE 4" THICK BY 18" WIDE. MAINTAIN 2" SEPARATION BETWEEN CONCRETE PAD AND METER BOX.
4. REDUCED PRESSURE PRINCIPLE ASSEMBLY (RP) SHALL BE SELECTED FROM THE USC LIST OF APPROVED BACKFLOW DEVICES.
5. A PRESSURE REGULATOR MAY BE INSTALLED UPSTREAM OF THE BACKFLOW PREVENTER ASSEMBLY PROVIDING PRESSURE REGULATOR IS ABOVE GROUND. A PRESSURE REGULATOR IS REQUIRED FOR LINE PRESSURES ABOVE 175 PSI.
6. WYE STRAINER AND DOWNSTREAM PRESSURE REGULATOR, WHEN REQUIRED, SHALL BE LOCATED DOWNSTREAM OF THE #2 SHUT OFF VALVE.
7. PROTECTIVE ENCLOSURE FOR BACKFLOW PREVENTER ASSEMBLY MAY BE USED AT THE DISCRETION OF THE PROPERTY OWNER.
8. NO CONNECTIONS OF ANY KIND WILL BE ALLOWED IN THIS AREA. INSPECTION BY THE DISTRICT SHALL TAKE PLACE PRIOR TO BACKFILL. INSTALL A CASING ENCASED IN CONCRETE WHEN THE DISTANCE BETWEEN THE METER BOX AND RISOR TO THE RP EXCEEDS (18").
9. OWNER TO HAVE DEVICE TESTED ANNUALLY BY A CERTIFIED TESTER. COPY OF THE RESULTS MUST BE SENT TO DISTRICT.
10. NO CONNECTIONS MUST BE BETWEEN THE METER AND THE BACKFLOW PREVENTER UNLESS ADEQUATE PROTECTION IS INSTALLED AND TESTED.
11. UNION REQUIRED.

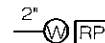

LEGEND ON PLANS

REVISIONS	APPROVED	DATE	VISTA IRRIGATION DISTRICT	
UPDATED	B. SMITH	03/25/11	RP INSTALLATION 2" & SMALLER	<i>Brian Smith</i> 3/25/11 BRIAN SMITH DATE R.C.E. 39926
				STD. DWG. 1-7

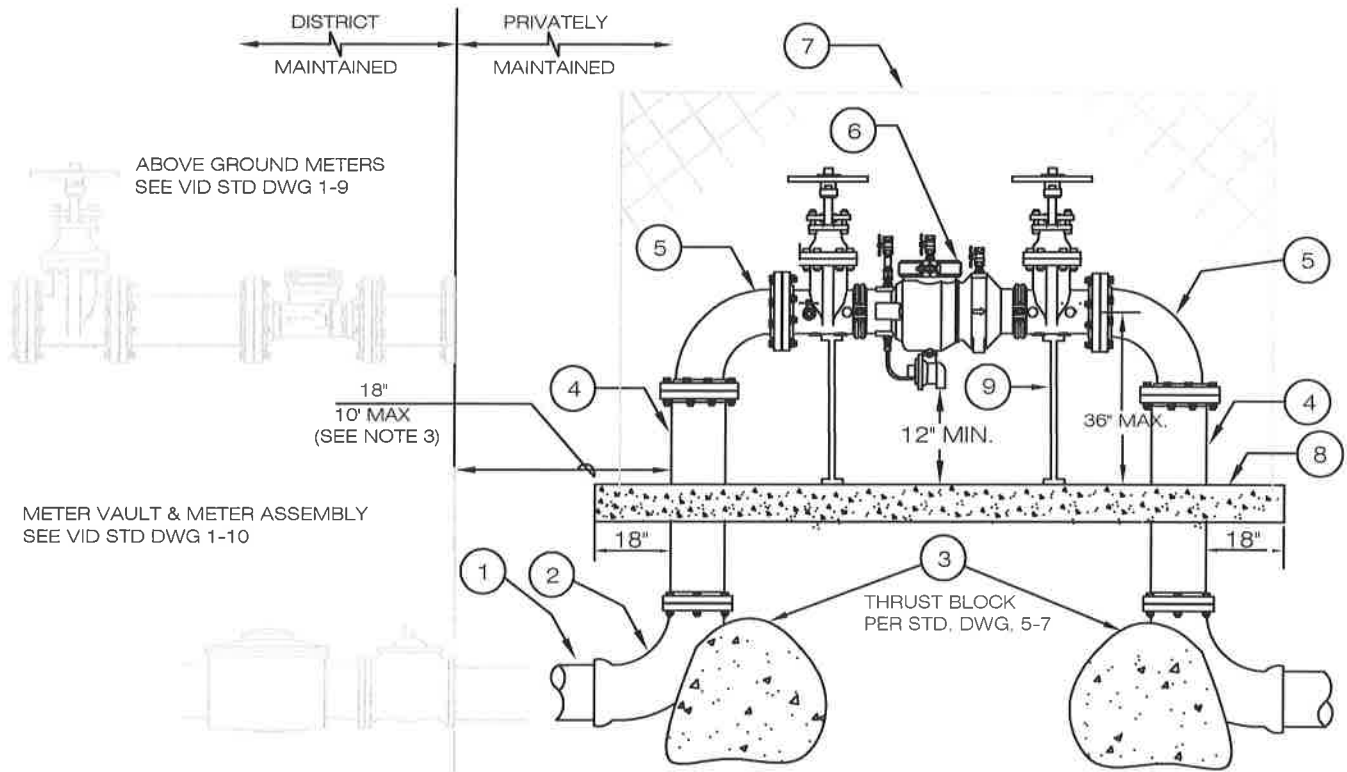

ABOVE GROUND METERS
SEE VID STD DWG 1-9

METER VAULT & METER ASSEMBLY
SEE VID STD DWG 1-10

NOTES

LEGEND ON PLANS
3" — (W) (RP)

ITEM NO.	SIZE AND DESCRIPTION
1	PVC OR DUCTILE IRON PIPE
2	FLG x FLG OR MJ/PO 90° BEND
3	CONCRETE THRUST BLOCK SEE STD DWG 5-7
4	FLANGED DUCTILE IRON PIPE
5	FLG 90° BEND
6	REDUCED PRESSURE BACKFLOW DEVICE
7	ENCLOSURE (OPTIONAL)
8	CONCRETE SLAB 4" THICK x 36" WIDE
9	ADJUSTABLE VALVE SUPPORT

- A. BACKFLOW ASSEMBLY SHALL INITIALLY BE TESTED AND CERTIFIED BY THE DISTRICT.
- B. PROTECTIVE ENCLOSURE FOR BACKFLOW PREVENTER ASSEMBLY SHALL BE USED AT THE DISCRETION OF THE PROPERTY OWNER.
- C. LOCATE BACKFLOW PREVENTION DEVICE IN SUCH A MANNER THAT WILL ALLOW THE DEVICE TO BE READILY ACCESSIBLE FOR INSPECTION REPAIR.
- D. INSTALL A CASING ENCASED IN CONCRETE WHEN THE DISTANCE BETWEEN THE METER VAULT AND THE RISER EXCEEDS 18". NO CONNECTIONS OF ANY KIND WILL BE PERMITTED IN THIS AREA. INSPECTION REQUIRED PRIOR TO BACKFILL.
- E. PROPERTY OWNER IS REQUIRED TO HAVE THE DEVICE TESTED ANNUALLY BY A CERTIFIED TESTER, WITH A COPY OF THE RESULTS SENT TO THE DISTRICT.
- F. REDUCED PRESSURE PRINCIPLE ASSEMBLY (RP) SHALL BE SELECTED FROM THE USC LIST OF APPROVED BACKFLOW DEVICES.

REVISIONS	APPROVED	DATE	VISTA IRRIGATION DISTRICT	
	JOHN AMODEO	12/02/99	RP INSTALLATION 3" & LARGER	<i>Brian Smith</i> 1/25/17 BRIAN SMITH DATE R. C. E. 39926
				STANDARD DRAWING 1-8

END OF DISTRICT RESPONSIBILITY
 BEGINNING OF CUSTOMER
 RESPONSIBILITY.
 SEE STANDARD DWG. 1-8

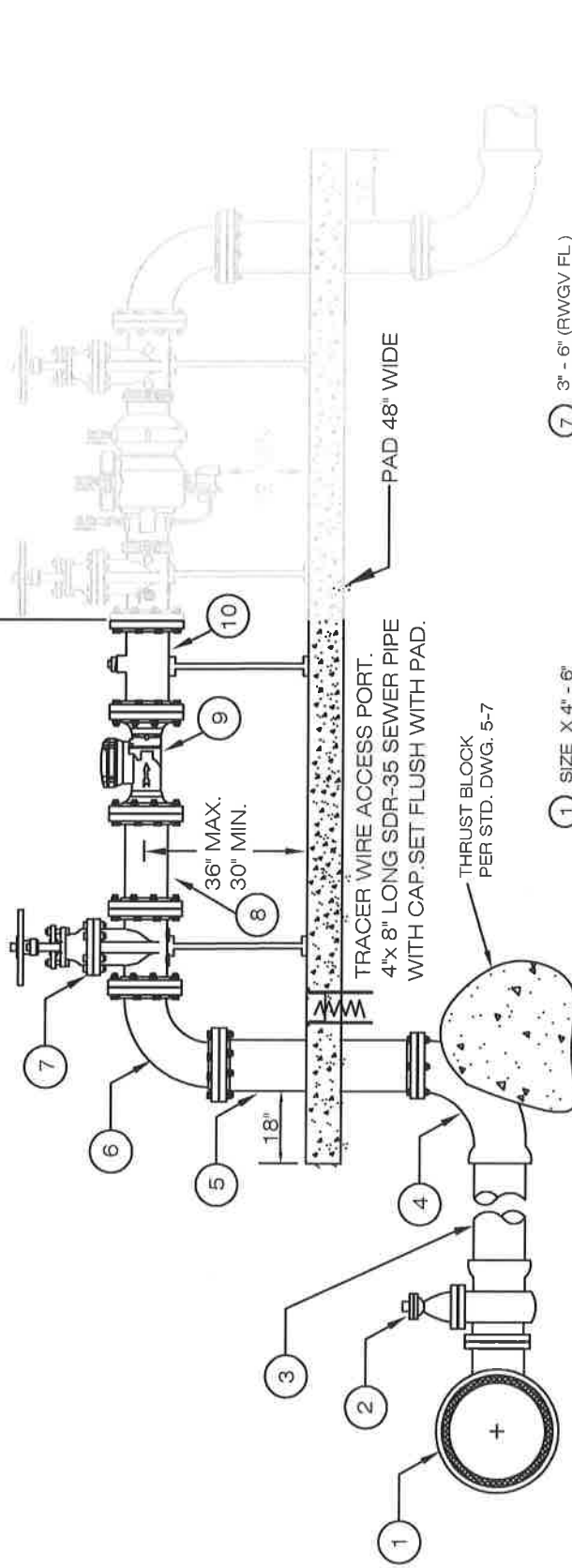

- ① SIZE X 4" - 6"
- ② 4" - 6" (RWGV FL X PO)
- ③ 4" - 6" DR14 (305)
- ④ 4" - 6" FL x PO 90 DEGREE ANGLE
- ⑤ 4" - 6" DUCTILE IRON SPOOL
- ⑥ 3" - 6" FL 90 DEGREE ANGLE
- ⑦ 3" - 6" (RWGV FL)
- ⑧ 3" - 6" X 12" EPOXY COATED SPOOL (BLUE)
- ⑨ METER
- ⑩ 3" - 6" X 12" EPOXY COATED SPOOL (BLUE) WITH 2" FIP TEST PORT WITH BRASS 2" PLUG

NOTES

- A) WHEN 3" METER IS REQUIRED A 4" LATERAL MUST BE INSTALLED. AND REDUCED ON 4" RISER. (SEE DETAIL "A")
- B) AN APPROVED FENCE MUST BE INSTALLED AROUND METER. FENCE SUBMITTAL AND DRAWING MUST BE SUBMITTED & APPROVED PRIOR TO INSTALLATION. FENCE SHALL BE OWNED AND MAINTAINED BY CUSTOMER.
- C) ALL WELDED JOINTS TO BE CEMENT COATED INSIDE AND OUTSIDE OF PIPE.
- D) FOR INSTALLATION OF RP DEVICE SEE STANDARD DWG. 1-8
- E) (W) LEGEND ON PLANS

INSTALLATION TO A.C.
 OR PVC WATER LINE

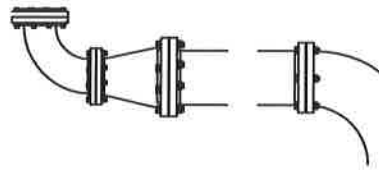

DETAIL "A"

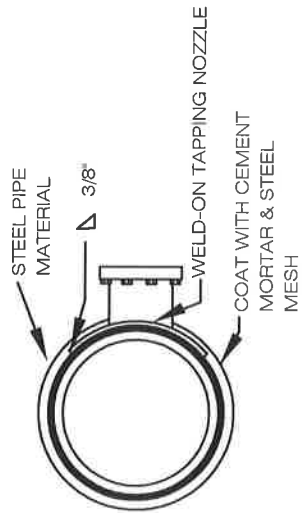

INSTALLATION TO
 CML&C WATER LINE

REVISIONS	APPROVED	DATE
	J. AMODEO	12/02/99

VISTA IRRIGATION DISTRICT
 3" THROUGH 6"
 ABOVE GROUND
 METER INSTALLATIONS

Brian Smith 1/24/17
 BRIAN SMITH DATE
 R. C. E. 39926

2" X 4" METER ASSEMBLY

8" BLOCK CONSTRUCTION SHOWN

NOTE SPECIAL CONST REQUIRED WHEN 2 METER USED

PLAN VIEW

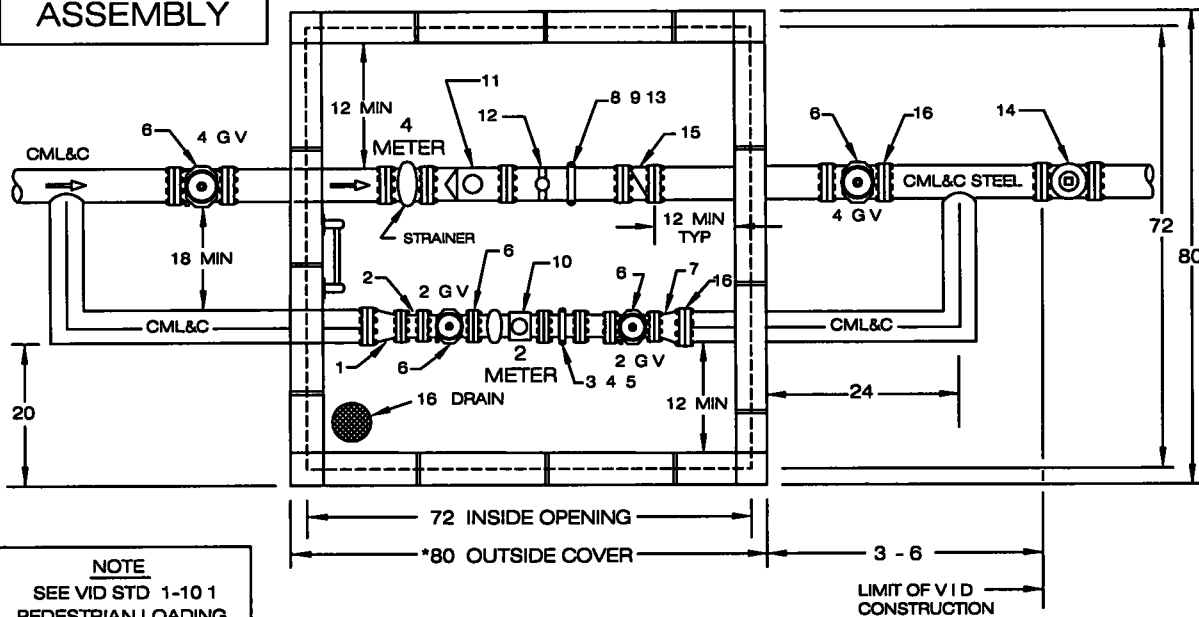

- 1 6"x 2 1/2" FORGED STEEL REDUCER (EPOXY LINED INSIDE)
- 2 1 1/2" x 2" NYLON BUSHING
- 3 VICTAULIC NIPPLE 5 x 2 MALE THREAD x GROOVE
- 4 VICTAULIC NIPPLE 5 x 2 GROOVE x FLG 2"
- 5 VICTAULIC COUPLING 2"
- 6 FLG x FLG GATE VALVE
- 7 6" x 2" C I REDUCER
- 8 6" x 4" VICTAULIC NIPPLE GROOVE x PLAIN END
- 9 6" VICTAULIC COUPLING
- 10 ROCKWELL TURBINE METER/STRAINER
- 11 ROCKWELL W 1000 DR TURBO METER & STRAINER W/REMOTE READING DIAL
- 12 2" SERVICE SADDLE REF 1-8
- 13 VICTAULIC COUPLER
- 14 OPTIONAL CUSTOMERS GATE VALVE
- 15 CLA VAL NO 501 WAFER SWING CHECK VALVE
- 16 INSULATING FLANGE

NOTE
SEE VID STD 1-10 1
PEDESTRIAN LOADING
HATCH COVER FOR
METER VAULTS
U S F (TPD 300 P S F)

*PRECAST VAULTS REQUIRE
SUBMITTAL OF SHOP DRAWINGS

***6' - 8" HATCH COVER**

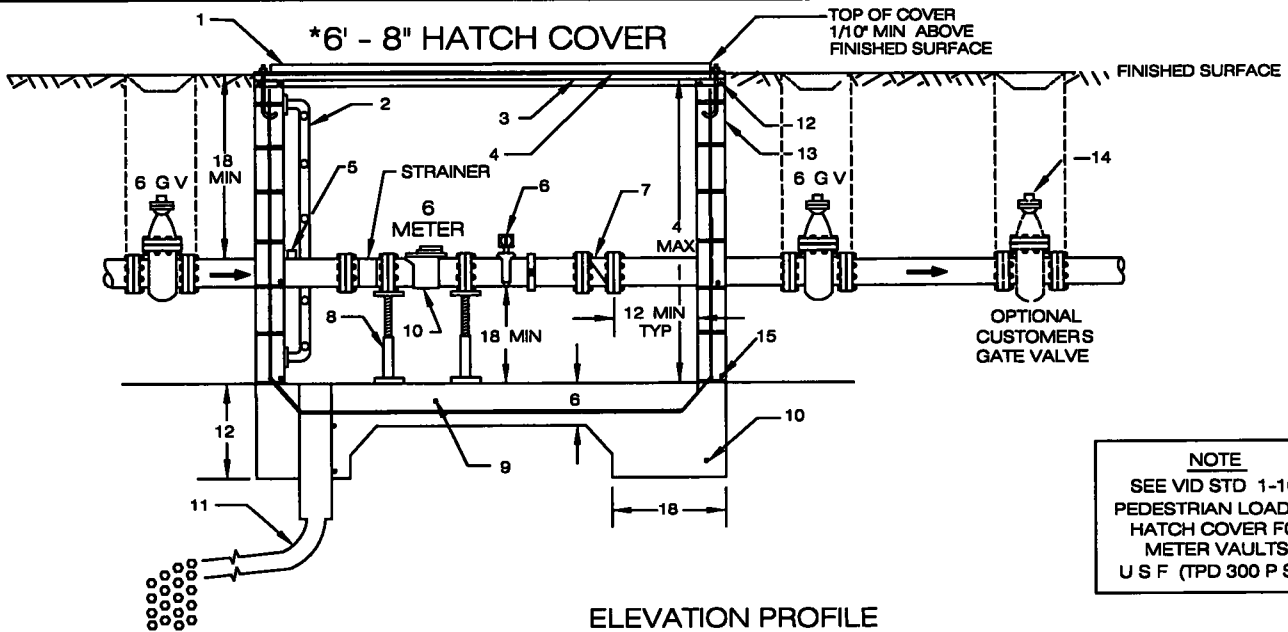

NOTE
SEE VID STD 1-10 1
PEDESTRIAN LOADING
HATCH COVER FOR
METER VAULTS
U S F (TPD 300 P S F)

6" METER ASSEMBLY

- 1 U S F (TPD 300 P S F) OR EQUIVALENT
- 2 18" WIDE STEEL LADDER WITH RUNGS ON
- 3 5" x 3" x 3/8" ANGLES IF NEEDED
- 4 PRE-CAST VAULT REQUIRES SHOP DWG SUBMITTALS
- 5 2" COUPLING W/CORP STOP
- 6 2" SERVICE SADDLE REF 1-8
- 7 CLA-VAL NO 501 WAFER SWING CHECK VALVE
- 8 VALVE SUPPORTS (SCREW JACKS)
- 9 NO 4 BARS AT 12" O C - BOTH WAYS
- 10 4-NO 4 BARS CONTINUOUS AT FOOTINGS
- 11 REFER TO DWG 6-6 FOR DRAINAGE AND SUMP SPEC
- 12 2 NO 4 BARS AT BOND
- 13 8" x 8" x 16" CONC BLOCK GROUT SOLID
- 14 OPTIONAL CUSTOMERS GATE VALVE
- 15 NO 4 BARS HORIZ AT 24" O C

LAST DRAWING APPROVAL DATE	
12 / 02 / 99	

VISTA IRRIGATION DISTRICT

(2" X 4") AND 6" ASSEMBLIES
TURBINE METER & VAULT

PATH Z ENGINEERING\TOM\STDDWGS\1-10A DWG1 DWG

REVISED JULY 17 2003

JOHN AMODEO DATE
R C E 31161 *John Amodeo 9/26/03*

STANDARD DRAWING 1-10

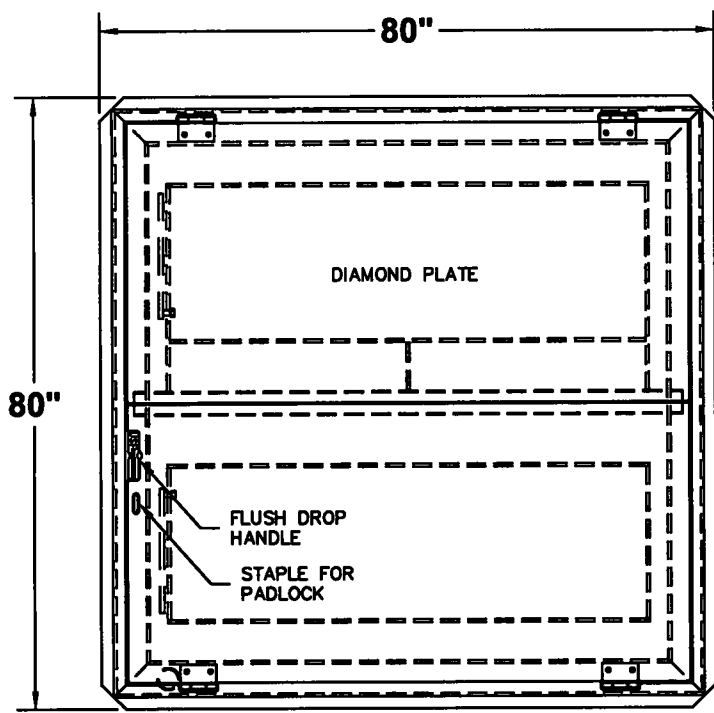

PLAN VIEW

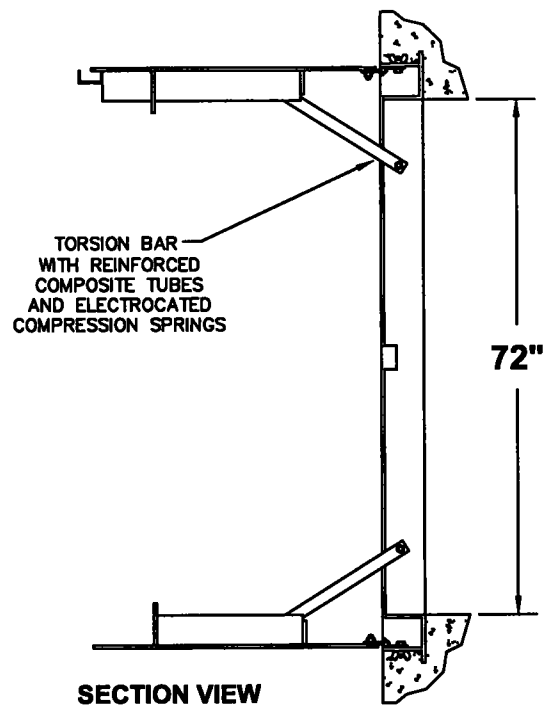

SECTION VIEW SIDE

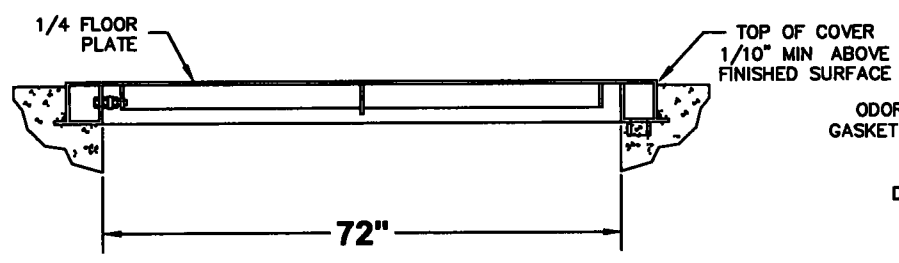

SECTION VIEW FRONT

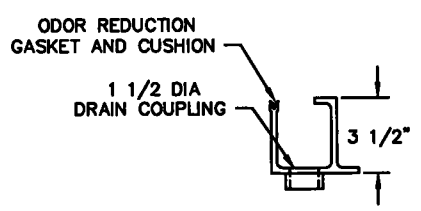

1/4 EXTRUDED TROUGH SECTION W/INTEGRAL CONT ANCHOR FLANGE AND GROOVES FOR GASKET/CUSHION
 FRAME MAT'L ALUMINUM 6063-T5

FRAME DETAIL

NOTES

- 1- MATERIAL ALUMINUM
- 2- LOADING 300 LBS PER SQ FT
- 3- 316 STAINLESS STEEL BOLTS HINGES AND HOLD OPEN ARM
- 4- TORSION BAR WITH COMPRESSION SPRINGS

Weight 303 lbs (approx hatch base weight w/o options)

U S F FABRICATION
 TPD 300 P S F

LAST DRAWING APPROVAL DATE	VISTA IRRIGATION DISTRICT	PATH Z ENGINEERING\TOMSTDDWGS\1-10A HATCH DWG
	PEDESTRIAN LOADING HATCH COVER FOR METER VAULTS	JOHN AMODEO DATE 9/25/02 R C E 31161
		STANDARD DRAWING 1-10 A

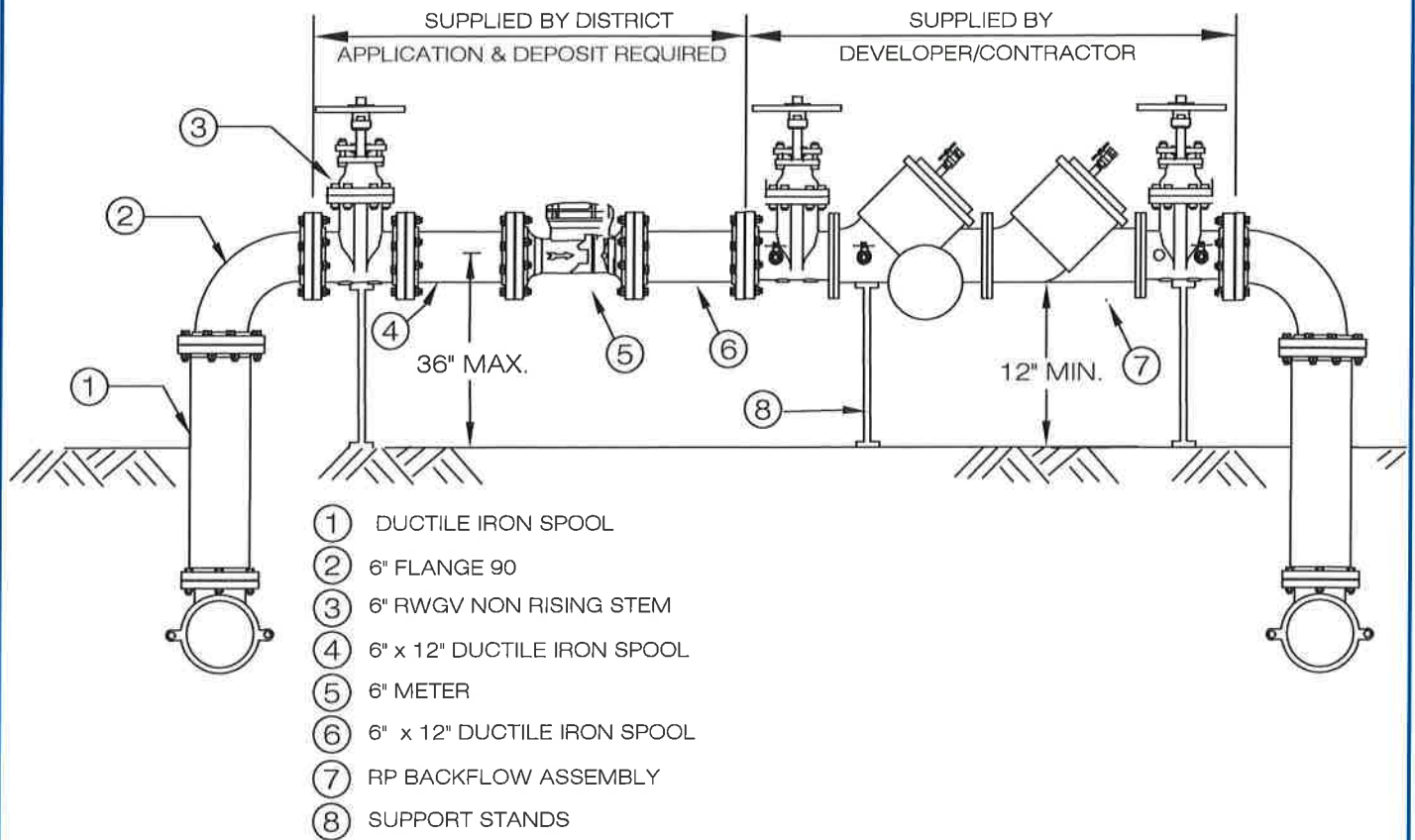

NOTES:

- 1 THE DISTRICT, UPON APPLICATION BY DEVELOPER WILL FURNISH, THE METER, TWO SPOOLS & ONE GATE VALVE.
- 2 INSTALLATION SHALL BE BY THE DEVELOPER'S CONTRACTOR, INCLUDING DISTRICT FURNISHED MATERIALS IN NOTE 1. THE DEVELOPER / CONTRACTOR SHALL SUPPLY THE RP BACKFLOW ASSEMBLY (FROM THE USC LIST OF APPROVED BACKFLOW DEVICES). AND HAVE IT TESTED BY THE DISTRICT PRIOR TO PUTTING INTO SERVICE.
- 3 LOCATION OF SCM(S) SHALL BE INDICATED ON THE IMPROVEMENT PLANS.
- 4 DISTRICT WILL NOTIFY DEVELOPER WHEN HIS CONTRACTOR CAN REMOVE THE SCM & RETURN IT TO THE DISTRICT. ALL TEMPORARY PIPING FOR SCM MUST BE REMOVED, INCLUDING ALL UNDERGROUND PIPE.
- 5 THE SCM MAY BE LOCATED WITHIN THE ROADWAY UPON APPROVAL OF THE PUBLIC WORKS DEPT. OF THE AGENCY HAVING JURISDICTION OF THE SUBDIVISION AND VISTA IRRIGATION DISTRICT.
- 6 PROTECTION POSTS MAYBE REQUIRED PER STD. DWG. 4-3 IF SCM IS LOCATED IN ROADWAY.

SYMBOL ON PLANS: SCM ———

REVISIONS	APPROVED	DATE	VISTA IRRIGATION DISTRICT	
	J. AMODEO	12/02/99	SUBDIVISION CONSTRUCTION METER ASSEMBLY	<div style="font-family: cursive; font-size: 1.2em; margin-bottom: 5px;">Brian Smith</div> BRIAN SMITH DATE R.C.E. 39926
				STANDARD DRAWING 1-11

- ① ALUMINUM LID / FACE MOUNTED LOCK
- ② 3/8" COPPER GOOSE NECK
- ③ 1/2" x 3/8" BRASS VALVE
- ④ ALUMINUM HOUSING
(KORALEEN WATER QUALITY SAMPLING STATION "STATION GUARD" OR APPROVED EQUAL)
- ⑤ PEA GRAVEL 6" BELOW LIP
- ⑥ 2' x 2' CONCRETE PAD
- ⑦ 1/2" COPPER TUBING POSITION IN CENTER OF TEST STAND
- ⑧ STANDARD SIZE METER BOX
- ⑨ STANDARD 1" METER SERVICE
- ⑩ 1 1/4" x 1/2" BRASS BUSHING
- ⑪ 1" LOCKING CURB STOP

NOTE: WATER SAMPLING SITE APPROVED BY DISTRICTS OPERATIONS WATER QUALITY SECTION.

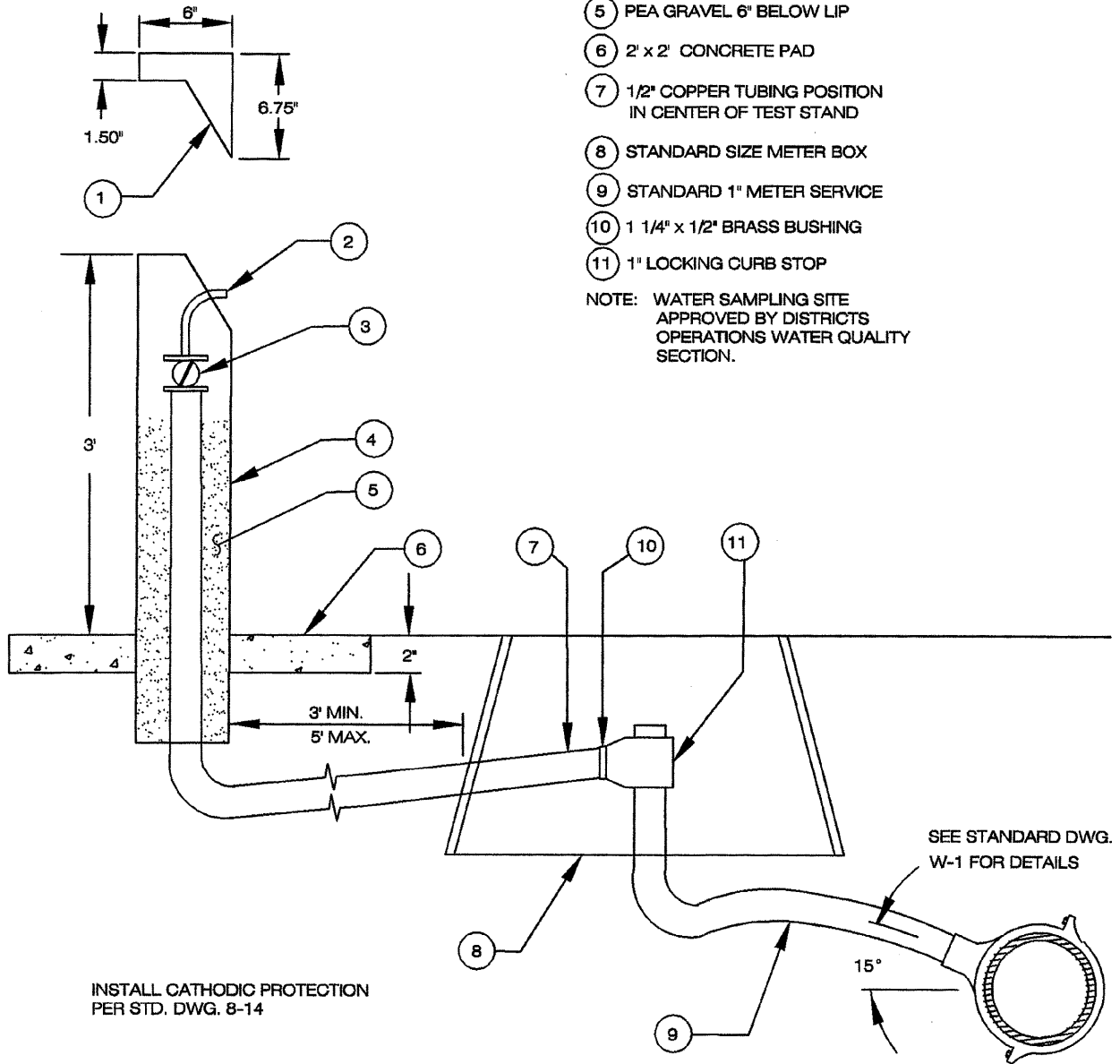

INSTALL CATHODIC PROTECTION PER STD. DWG. 8-14

SEE STANDARD DWG. W-1 FOR DETAILS

REVISIONS	APPROVED	DATE	VISTA IRRIGATION DISTRICT	PATH: (TOM) H:\STDDWGS\1-12.DWG
			WATER QUALITY SAMPLING STATION	JOHN AMODEO R. C. E. 31161
				DATE
				STANDARD DRAWING
				1-12
ACAD		6/96		

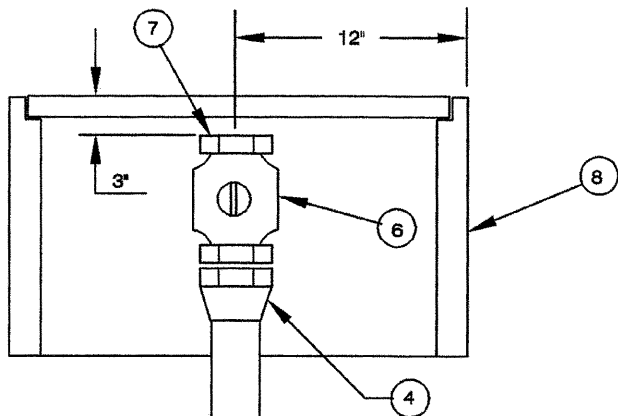

NOTE: SILVER SOLDER JOINTS REQUIRED

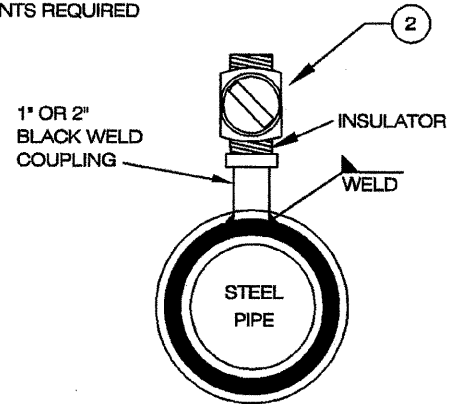

1' MIN. RADIUS (1" PIPE)
90° ELL. (2" PIPE)

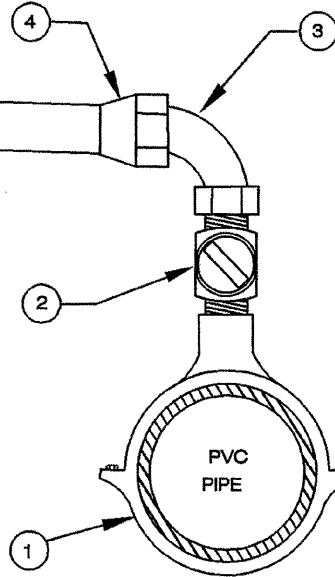
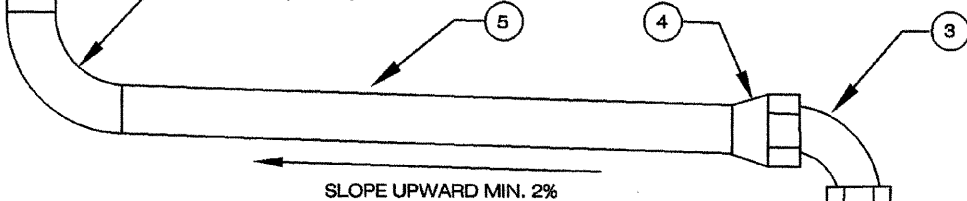

- 1 FULL CIRCLE BODY CLAMP FOR PVC
- 2 BRONZE CORPORATION STOP
- 3 90° BRASS STREET ELL.
- 4 PIPE TO TUBING ADAPTOR
- 5 COPPER TUBING
- 6 BALL VALVE
- 7 BRASS PLUG
- 8 METER BOX (SEE STD. DWG. 1-3 FOR LOCATION). METER BOX LOCATED IN TRAVELED WAYS, PAVED AREAS, AND SIDEWALKS SHALL BE CONCRETE. ALL OTHERS SHALL BE PLASTIC.

NOTE: 1. CATHODIC PROTECTION REQUIRED PER STD. DWG. 8-14
2. FITTINGS SHALL BE FLARED, END CONNECTIONS FOR 1" COPPER AND SWEAT BY THREADED FOR 2" COPPER.

LEGEND ON PLANS

REVISIONS	APPROVED	DATE	VISTA IRRIGATION DISTRICT	PATH: (TOM) H:\STDDWGS2-1.DWG
			1" AND 2" MANUAL AIR RELEASES (TYPE A)	<i>John A. Amodeo</i> 12/2/97 JOHN AMODEO R. C. E. 31161
				DATE
ACAD		6/96		STANDARD DRAWING 2-1

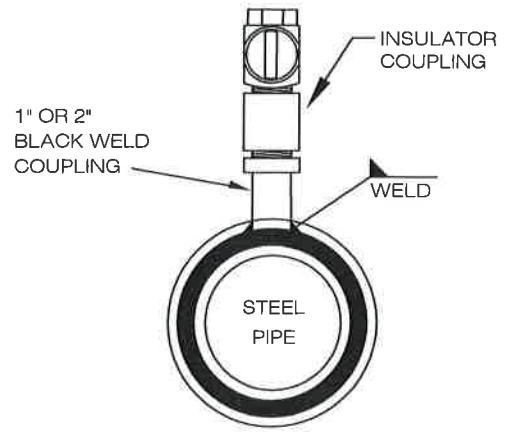
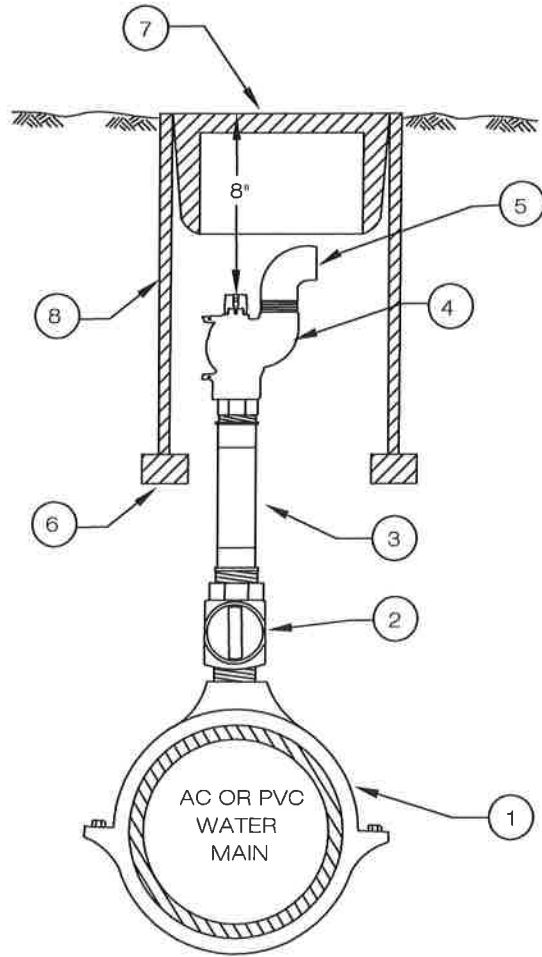

NOTE: FITTINGS SHALL BE FLARED END CONNECTIONS FOR 1" COPPER AND SWEAT BY THREADED FOR 2" COPPER. (MIP X FIP 2" CORP)

- ① SIZE X 1" or 2" SERVICE SADDLE
- ② BRONZE CORPORATION STOP
- ③ TYPE K COPPER (ONE CONTINUOUS PIECE WITHOUT INTERMEDIATE SPLICES FOR 1" SERVICES)
- ④ BRONZE ANGLE SERVICE STOP 360 DEGREE TEE ROTATION ANGLE BALL VALVE FOR (2")
- ⑤ 2" SCHEDULE 40 PVC FEMALE 90
- ⑥ REDWOOD OR CONCRETE BLOCK AT TOP OF PIPE ZONE
- ⑦ VALVE WELL CAP
- ⑧ VALVE WELL / 1" M.A.R. - 8" PVC / 2" M.A.R. - 10" PVC / 1" M.A.R. - 8" LID / 2" M.A.R. - 10" LID

↑
LEGEND ON PLANS

REVISIONS	APPROVED	DATE	VISTA IRRIGATION DISTRICT
UPDATED	B. SMITH	03/25/11	1" & 2" MANUAL AIR RELEASES (TYPE B)
			<i>Brian Smith</i> 3/16/16 BRIAN SMITH DATE R.C.E. 39926 STD. DWG. 2-2

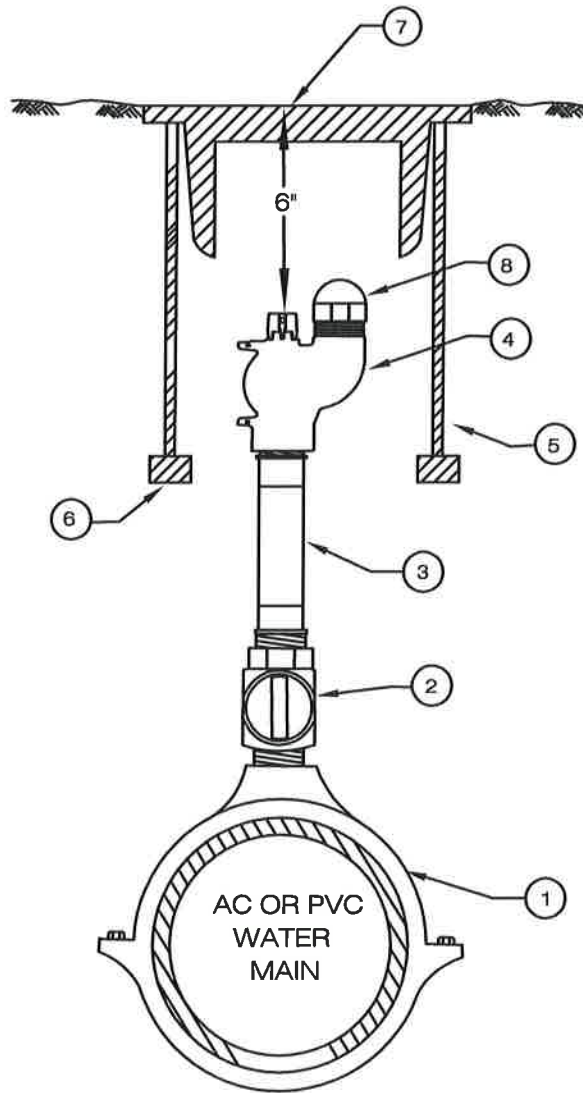

NOTE: FITTINGS SHALL BE SWEAT BY THREADED FOR 2" COPPER. (MIP X FIP 2" CORP)

NOTE 2 : FOR STEEL MAINS USE 2" STEEL COUPLING, 2" BRASS CLOSE NIPPLE & 2" INSULATED COUPLING

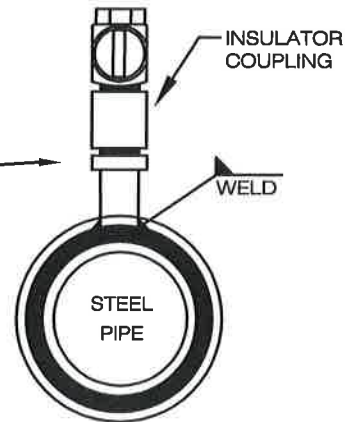

- ① SIZE X 2" SERVICE SADDLE
- ② 2" BRONZE CORPORATION STOP
- ③ TYPE K COPPER (ONE CONTINUOUS PIECE WITHOUT INTERMEDIATE SPLICES)
- ④ 360 DEGREE TEE ROTATION ANGLE BALL VALVE (2")
- ⑤ VALVE WELL 12" PVC & 12" GALVANIZED SLEEVE
- ⑥ REDWOOD OR CONCRETE BLOCK AT TOP OF PIPE ZONE
- ⑦ GATE WELL LID - 12" SLOTTED LID
- ⑧ 2" PVC FEMALE THREADED CAP

LEGEND ON PLANS

REVISIONS	APPROVED	DATE	VISTA IRRIGATION DISTRICT	
NEW	B. SMITH	04/02/13	2" MANUAL AIR RELEASE / BLOW OFF	BRIAN SMITH DATE R.C.E. 39926
UPDATED	B. SMITH	06/06/14		
				STD. DWG. 2-2A

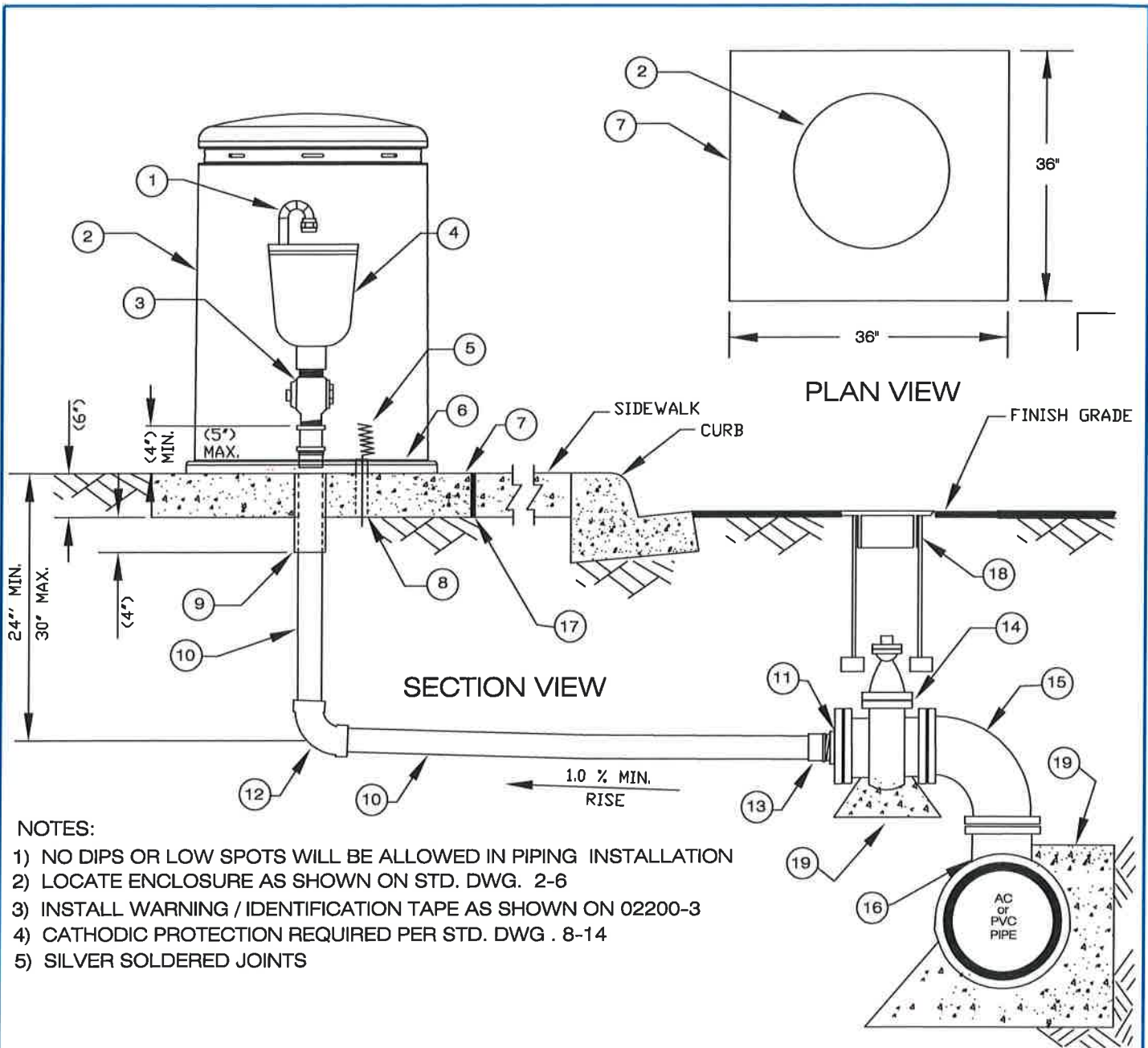

NOTES:

- 1) NO DIPS OR LOW SPOTS WILL BE ALLOWED IN PIPING INSTALLATION
- 2) LOCATE ENCLOSURE AS SHOWN ON STD. DWG. 2-6
- 3) INSTALL WARNING / IDENTIFICATION TAPE AS SHOWN ON 02200-3
- 4) CATHODIC PROTECTION REQUIRED PER STD. DWG. 8-14
- 5) SILVER SOLDERED JOINTS

ITEM NO.	SIZE AND DESCRIPTION	ITEM NO.	SIZE AND DESCRIPTION	ITEM NO.	SIZE AND DESCRIPTION
1	2" PVG SCH 80 CLOSE NIPPLE & 2-SCH 80 ST ELLS & SUCTION SCREENS	8	1" PVC CONDUIT FOR TRACER WIRE INSTALLED 2" ABOVE SLAB	14	4" FLG RWGV (SEE APPROVED MATERIAL LIST)
2	VALVE ENCLOSURE (SEE STD. DWG 2-5)	9	2" x 1/2" BLACK FOAM SLEEVE	15	4" FLANGE 90
3	2" BRONZE MIPT x MIPT CORPORATION STOP	10	2" x REQUIRED LENGTH COPPER PIPE TYPE "K", SOFT	16	SIZE x 4" FL TAPPING SADDLE OR TEE
4	AUTOMATIC COMBINATION AIR RELEASE & AIR/VACUUM VALVE			17	COLD JOINT STRIP
5	TRACER WIRE	11	4" x 2" FIP COMPANION FLANGE	18	VALVE WELLS (SEE STD. DWG. 5-3)
6	3- 1/2" CONCRETE ANCHORS W/STAINLESS FENDER WASHERS (SEE STD.DWG. 2-5)	12	2" COPPER 90°	19	CONCRETE THRUST/ANCHOR BLOCK (SEE STD DWG 5-7)
7	36" x 36" x 4" THICK CONCRETE SLAB	13	2" COPPER MALE ADAPTER		

REVISIONS	APPROVED	DATE	VISTA IRRIGATION DISTRICT		 BRIAN SMITH R.C.E. 39926
	J. AMODEO	12/02/99	2" AUTOMATIC COMBINATION AIR RELEASE & AIR / VACUUM VALVE INSTALLATIONS		
UPDATED	B. SMITH	04/12/12			
					STD. DWG. 2-3

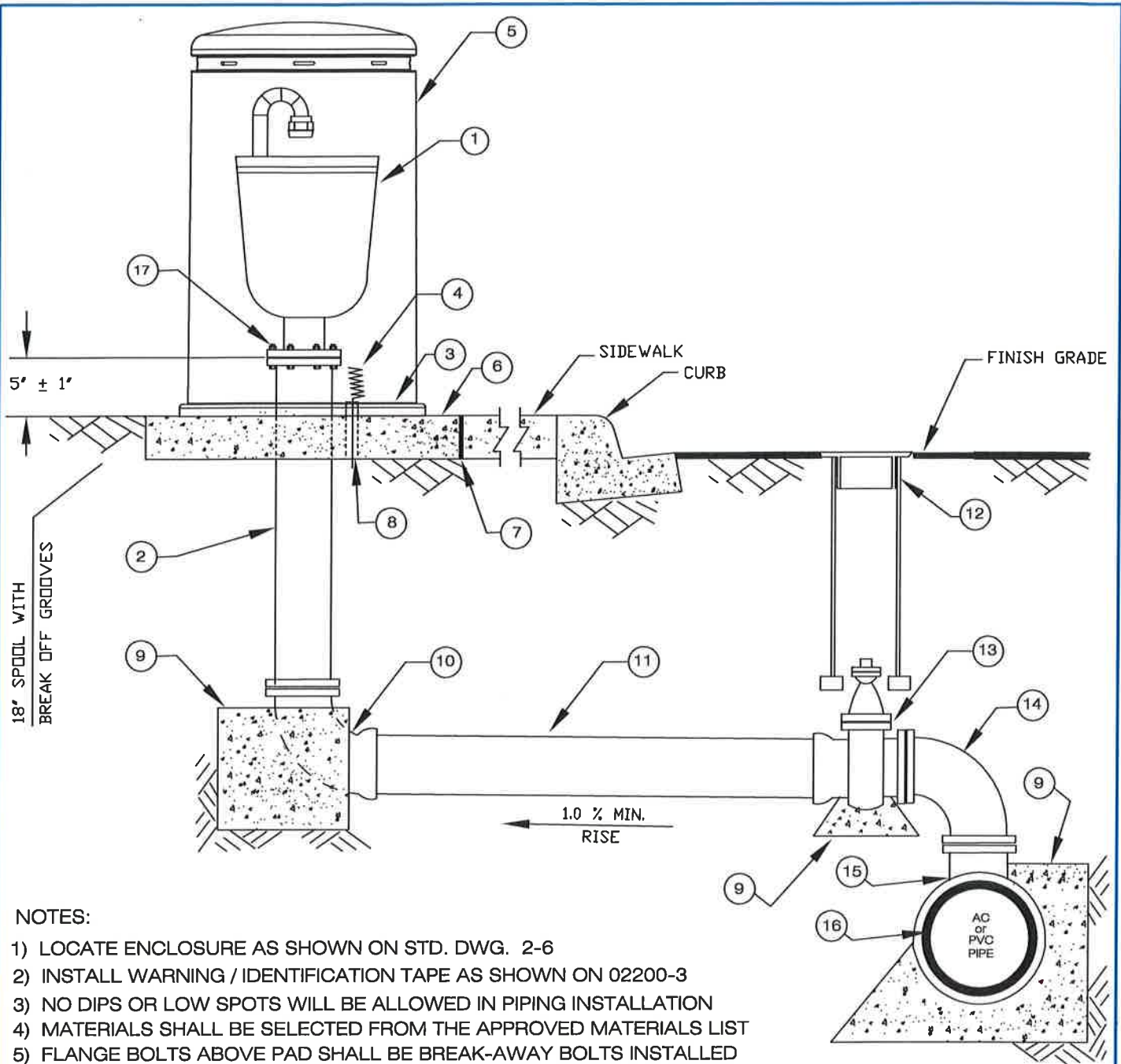

NOTES:

- 1) LOCATE ENCLOSURE AS SHOWN ON STD. DWG. 2-6
- 2) INSTALL WARNING / IDENTIFICATION TAPE AS SHOWN ON 02200-3
- 3) NO DIPS OR LOW SPOTS WILL BE ALLOWED IN PIPING INSTALLATION
- 4) MATERIALS SHALL BE SELECTED FROM THE APPROVED MATERIALS LIST
- 5) FLANGE BOLTS ABOVE PAD SHALL BE BREAK-AWAY BOLTS INSTALLED WITH NUTS ON TOP OF THE FLANGE. BOLT SHAFT SHALL BE FILLED WITH SILICONE SEALANT

ITEM NO.	SIZE AND DESCRIPTION	ITEM NO.	SIZE AND DESCRIPTION	ITEM NO.	SIZE AND DESCRIPTION
1	AUTOMATIC COMBINATION AIR RELEASE & AIR/VACUUM VALVE ASSEMBLY WITH INSECT SCREEN	6	50" X 50" X 6" THICK - CONCRETE SLAB	12	GATE WELL WITH LID SEE (STD. DWG 5-3)
		7	COLD JOINT STRIP		
2	EXTENSION SPOOL(S) / NO GROOVES, FLANGE DUCTILE IRON (MAXIMUM OF 2 SPOOLS, ONLY WHEN APPROVED BY DISTRICT)	8	1" PVC CONDUIT FOR TRACER WIRE INSTALLED 2" ABOVE SLAB	13	FLG X P.O. RWGV (SEE APPROVED MATERIAL LIST)
3	1/2" X 3" STAINLESS STEEL DROP-IN ANCHORS (3 EA @ 120° APART)	9	CONCRETE THRUST/ANCHOR BLOCK (SEE STD DWG 6-7)	14	FLG 90° BEND
4	TRACER WIRE	10	FLG X P.O. 90° BEND	15	SIZE X REQ'D P.O. FLG TEE
5	VALVE ENCLOSURE (SEE APPROVED MATERIAL LIST)	11	C-900 (305) DR14	16	WATER MAIN
				17	BREAK - AWAY BOLTS. SEE NOTE 5

REVISIONS	APPROVED	DATE	VISTA IRRIGATION DISTRICT	
UPDATED	B. SMITH	12/10/12	4" & 6" AUTOMATIC COMBINATION AIR RELEASE & AIR / VACUUM VALVE INSTALLATIONS	
			 BRIAN SMITH DATE R.C.E. 39926	

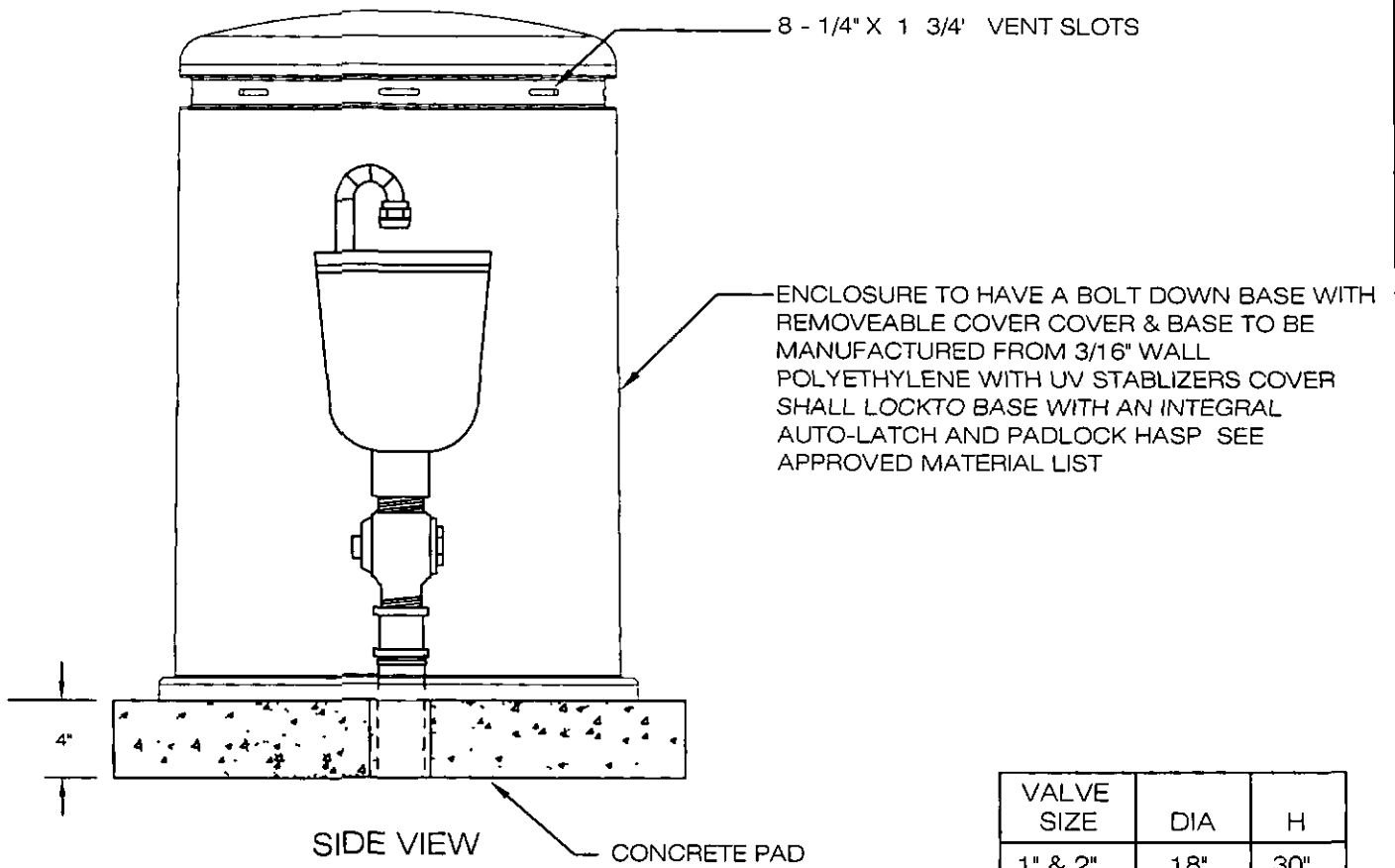

VALVE SIZE	DIA	H
1" & 2"	18"	30"
4" & 6"	24"	36"

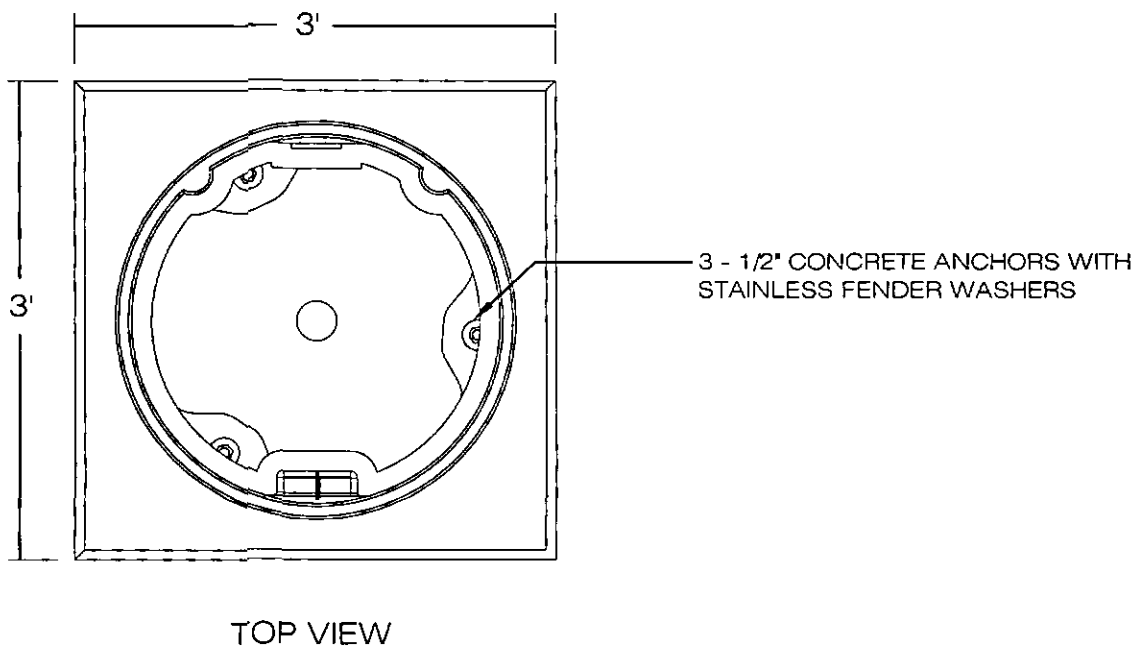

NOTE 1 FOR VALVE ENCLOSURE LOCATIONS, SEE DWG 2-6

REVISIONS	APPROVED	DATE	VISTA IRRIGATION DISTRICT	
	J AMADEO	12/02/99	AIR AND VACUUM VALVE ENCLOSURES	<i>Brian Smith</i> 4/12/12
				BRIAN SMITH DATE
				RCE 39926
				STD. DWG. 2-5

TYPE 1

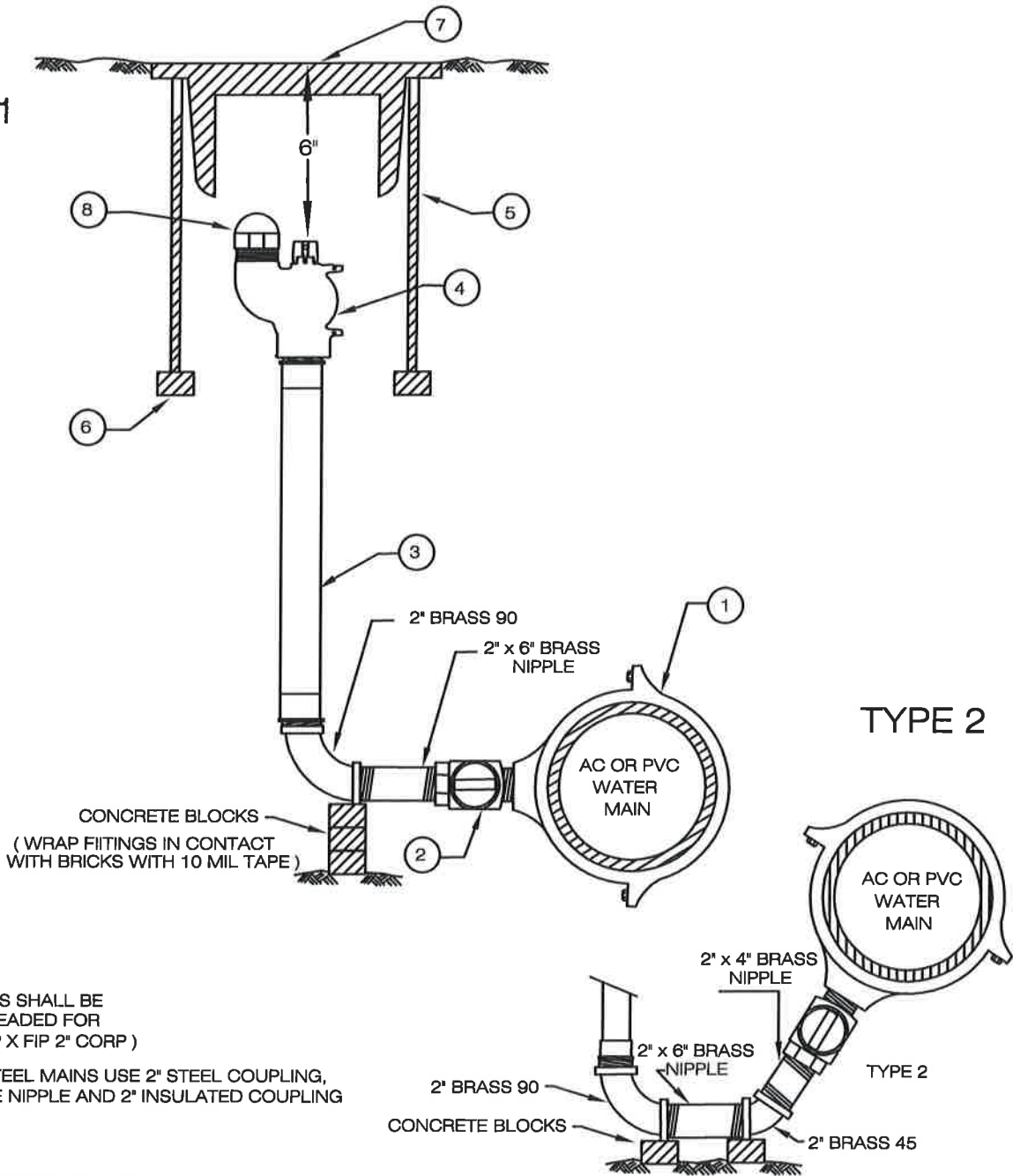

NOTE 1: FITTINGS SHALL BE SWEAT BY THREADED FOR 2" COPPER (MIP X FIP 2" CORP)

NOTE 2 : FOR STEEL MAINS USE 2" STEEL COUPLING, 2" BRASS CLOSE NIPPLE AND 2" INSULATED COUPLING

- ① SIZE X 2" SERVICE SADDLE
- ② 2" BRONZE CORPORATION STOP
- ③ TYPE K COPPER (ONE CONTINUOUS PIECE WITHOUT INTERMEDIATE SPLICES)
- ④ 360 DEGREE TEE ROTATION ANGLE BALL VALVE (2")
- ⑤ VALVE WELL 12" PVC & 12" GALVANIZED SLEEVE
- ⑥ REDWOOD OR CONCRETE BLOCK AT TOP OF PIPE ZONE
- ⑦ GATE WELL LID -12" SLOTTED LID
- ⑧ 2" PVC FEMALE THREADED CAP

⊙
LEGEND ON PLANS

REVISIONS	APPROVED	DATE	VISTA IRRIGATION DISTRICT	
UPDATED	B. SMITH	03/25/11	2" BLOW OFF ASSEMBLY TYPE 1 & 2	<i>Brian Smith</i> 3/16/16 BRIAN SMITH DATE R.C.E. 39926
UPDATED	B. SMITH	04/02/13		
UPDATED	B. SMITH	06/06/14		
				STD. DWG. 3-1

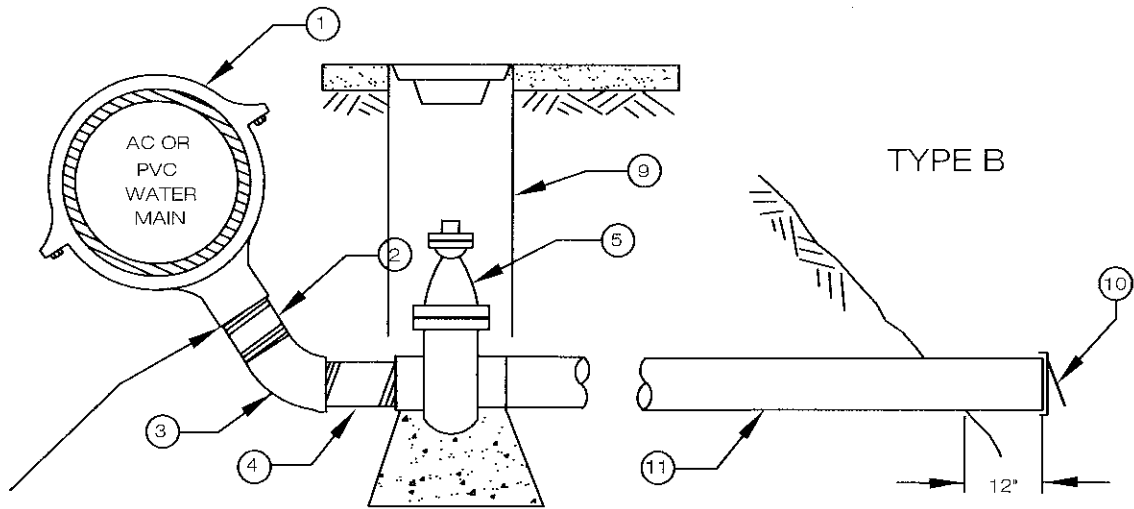

USE 2" BRASS CLOSE NIPPLE
2" INSULATED COUPLING
FOR STEEL MAIN PIPE

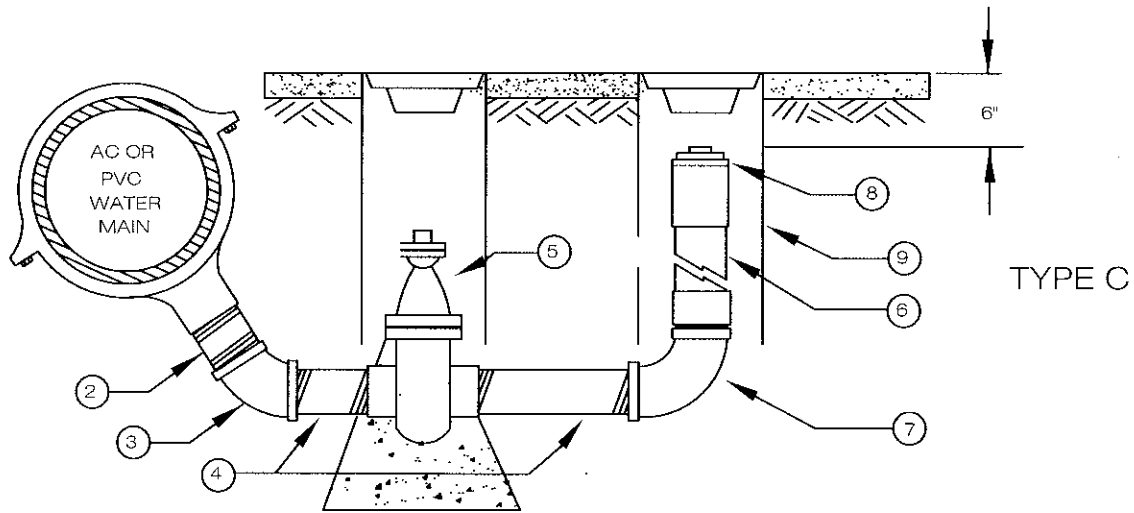

- ① DOUBLE STRAP BRONZE SERVICE SADDLE ON A.C. PIPE
BRONZE OR BRASS SADDLE WITH STAINLESS STEEL FOUR BOLT STRAPS FOR PVC
- ② 2" BRASS NIPPLE [2" x 3"
- ③ 2" BRASS 45°
- ④ 2"x 6" BRASS NIPPLE & 2"x 12" BRASS NIPPLE
- ⑤ 2" NON RISING STEM, FIP x FIP,
CAST IRON EPOXY COATED GATE VALVE, CL200
W/ 2" Op NUT
- ⑥ 2" SCHEDULE 80 PIPE
- ⑦ 2" BRASS 90° ELL
- ⑧ 2" THREADED FEMALE ADAPTER &
2" THREADED CAP / SCHEDULE 80
- ⑨ VALVE WELL INSTALLATION, SEE STD. DWG. 5-3
- ⑩ FLAPPER VALVE
- ⑪ 2" COPPER PIPE

NOTE:

1 FOR STEEL PIPE WELD 2" BLACK COUPLING

8

LEGEND ON PLANS

REVISIONS	APPROVED	DATE	VISTA IRRIGATION DISTRICT	
UPDATED	B. SMITH	03/25/11	2" BLOW OFF ASSEMBLIES TYPES B & C	
			<i>Brian Smith</i> 3/25/11 BRIAN SMITH DATE R.C.E. 39926	
			STD. DWG. 3-2	

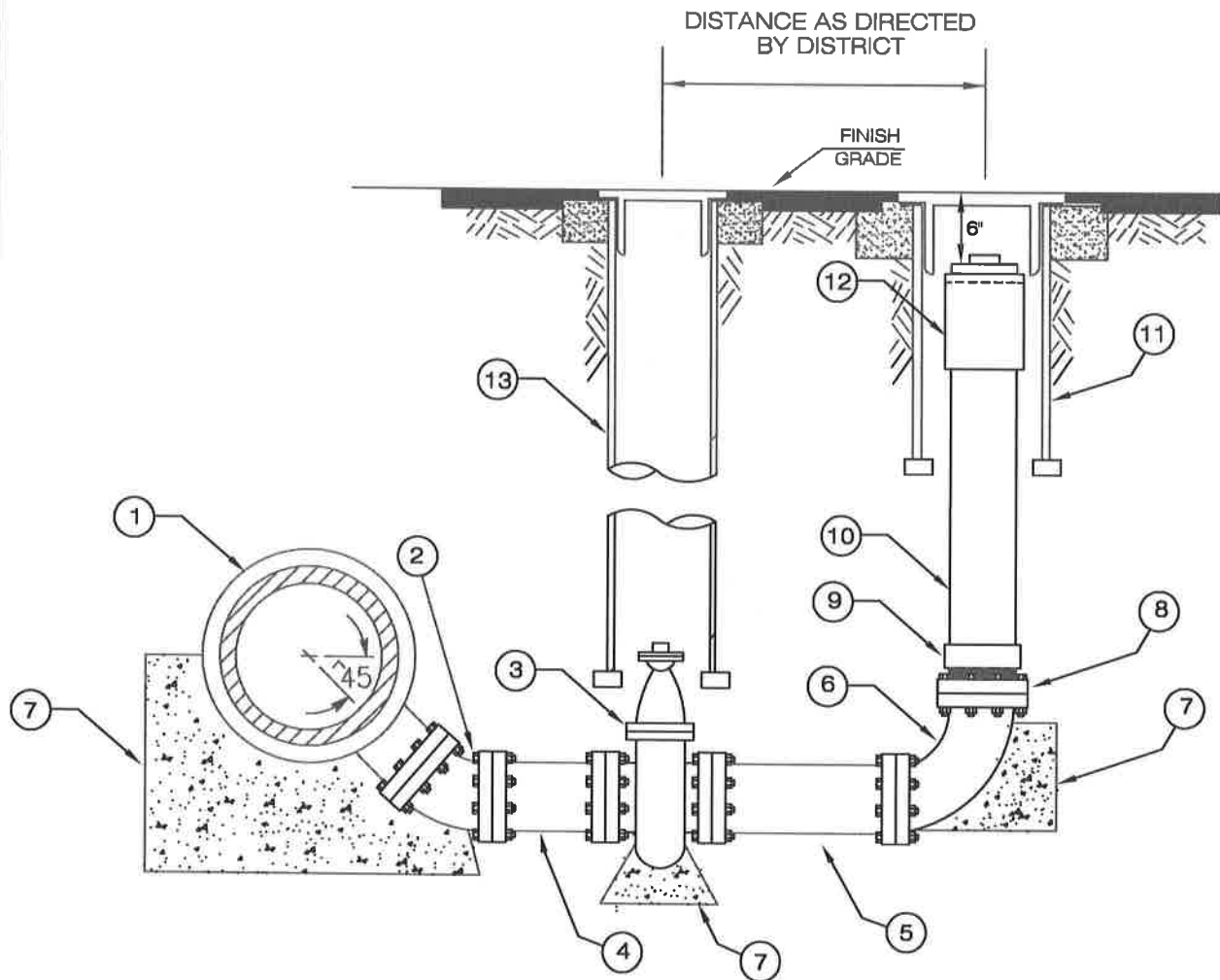

ITEM NO.	SIZE AND DISCRPTION	ITEM NO.	SIZE AND DISCRPTION
1	SIZE X 4" OR 6" MJ / PO / FL X FL TEE	8	4" OR 6" COMPANION FL
2	4" OR 6" FL 45 DEGREE BEND	9	4" OR 6" SCH 80 PVC, MALE ADAPTER (SLIP X MALE THREAD)
3	4" OR 6" FL X FL RWGV	10	4" OR 6" SCH 80 PVC PIPE
4	4" OR 6" X 12" DUCTILE IRON SPOOL	11	10" DR14 WITH 10" SLOTTED LID (SEE STD DWG 5-3)
5	4" OR 6" X 18" MIN. DUCTILE IRON SPOOL	12	4" OR 6" SCH. 80 PVC FEMALE X ADAPT. (SLIP X FIPT) WITH A 4" OR 6" ABS PLUG
6	4" OR 6" FL 90 DEGREE BEND	13	8" DR14 WITH 8" SLOTTED LID (SEE STD DWG 5-3)
7	VALVE & THRUST BLOCKING SEE STD. DWG. 5-5 & 5-7		

4" OR 6" LEGEND ON PLANS

REVISIONS	APPROVED	DATE	VISTA IRRIGATION DISTRICT	6/6/14 BRIAN SMITH DATE R.C.E. 39926
Updated	Brian Smith	06/06/14	4" & 6" BLOW OFF ASSEMBLY TYPE A	

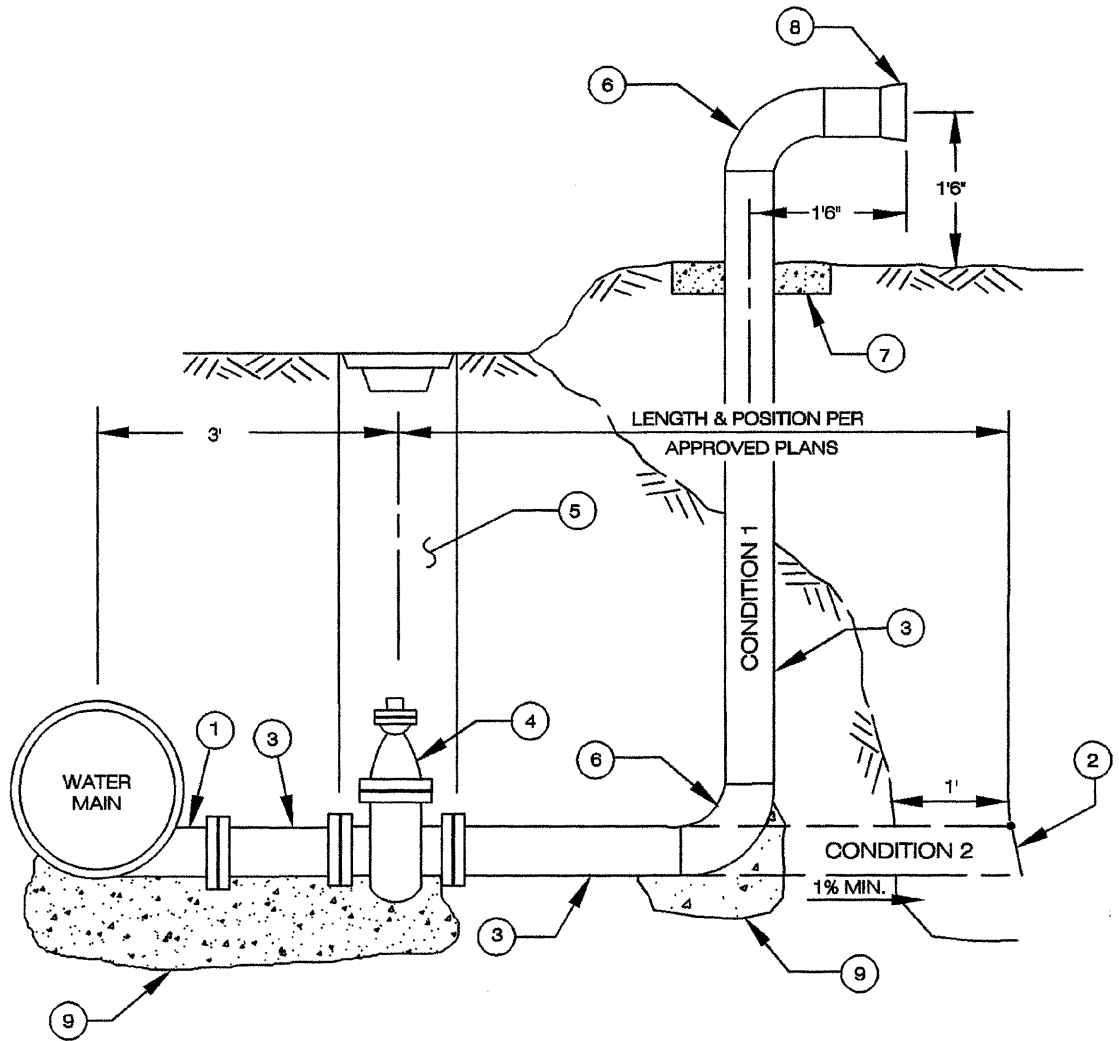

- ① FLANGED TEE OR WELDED SADDLE
- ② FLAPPER LID
- ③ STEEL PIPE, CML&C
- ④ FLANGED VALVE
- ⑤ VALVE WELL (SEE STD. DWG. 5-3)
- ⑥ 90 BEND, STEEL PIPE, CML&C (JOINTS MAY BE WELDED)
- ⑦ 4' x 20" SQUARE, 470-C-2000 CONC.
- ⑧ THREADED REMOVABLE CAP
- ⑨ VALVE & THRUST BLOCKING PER STD. DWG. 5-5 & 5-7

○ ○
LEGEND ON PLANS

REVISIONS	APPROVED	DATE	VISTA IRRIGATION DISTRICT	PATH: (TOM) H:\STDDWGS\3-4.DWG
			4" & 6" BLOW OFF ASSEMBLIES TYPE B	<i>John Amodeo</i> 12/2/99 JOHN AMODEO DATE R. C. E. 31161
				STANDARD DRAWING 3-4
ACAD		6/96		

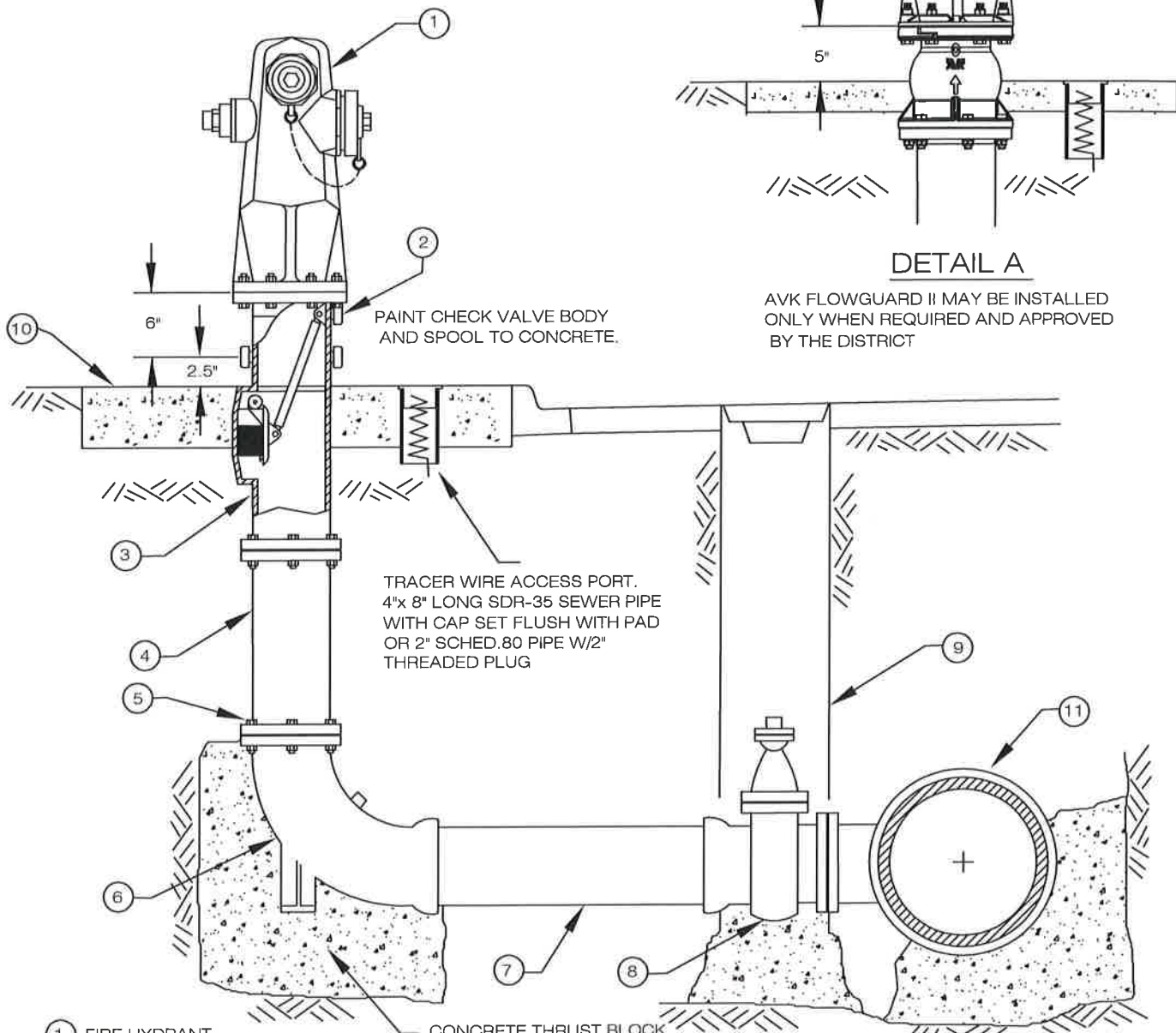

BOTTOM OF F.H.
TO TOP OF PAD

DETAIL A

AVK FLOWGUARD II MAY BE INSTALLED
ONLY WHEN REQUIRED AND APPROVED
BY THE DISTRICT

- ① FIRE HYDRANT
- ② 6" EXTENSION SPOOL (DOUBLE MACHINE GROOVED)
- ③ BREAK-AWAY CHECK VALVE BODY ASSEMBLY REQUIRED.
- ④ EXTENSION SPOOL(S) / NO GROOVES (MAXIMUM OF 2 SPOOLS)
ONLY WHEN APPROVED BY THE DISTRICT
- ⑤ 7.5" x 3" HEX HEAD MACHINE BOLTS AND NUTS (TYPICAL)
- ⑥ 6" x 16" LONG RADIUS FLG x PO BURY ELL
- ⑦ 6" POLYVINYL CHLORIDE (PVC).
- ⑧ VALVE AND CONCRETE SUPPORT, STD. DWG. 5-5 (TYPE A)
- ⑨ VALVE WELL AND COVER, STD. DWG. 5-3
- ⑩ 4' x 4' x 8" THICK CONCRETE SPLASH PAD
- ⑪ SIZE X 6" PO / FLG. X FLG TEE

CONCRETE THRUST BLOCK
SEE STD. DWG 5-7

NOTES:

- 1. SEE STD. DWG. 4-2 FOR FIRE HYDRANT LOCATIONS.
- 2. PLACE STD. VALVE WELL & COVER OVER VALVE. PROTECTION POSTS MAY BE REQUIRED SEE STD. DWG. 4-3
- 3. FIRE HYDRANT FLANGE BOLTS SHALL BE A307 ZINC-PLATED BOLTS INSTALLED WITH NUTS ON TOP OF THE FLANGE. BREAK AWAY BOLTS SHALL NOT BE USED.
- 4. F.H. STAKING REQUIRES 3 HUBS W/5' OFFSETS DENOTING ELEVATION OF CONCRETE APRON

LEGEND ON PLANS



REVISIONS	APPROVED	DATE	VISTA IRRIGATION DISTRICT	
UPDATED	B. SMITH	03/25/11	6" FIRE HYDRANT ASSEMBLY	BRIAN SMITH DATE R.C.E. 39926
UPDATED	B. SMITH	12/10/12		
			STD. DWG. 4-1	

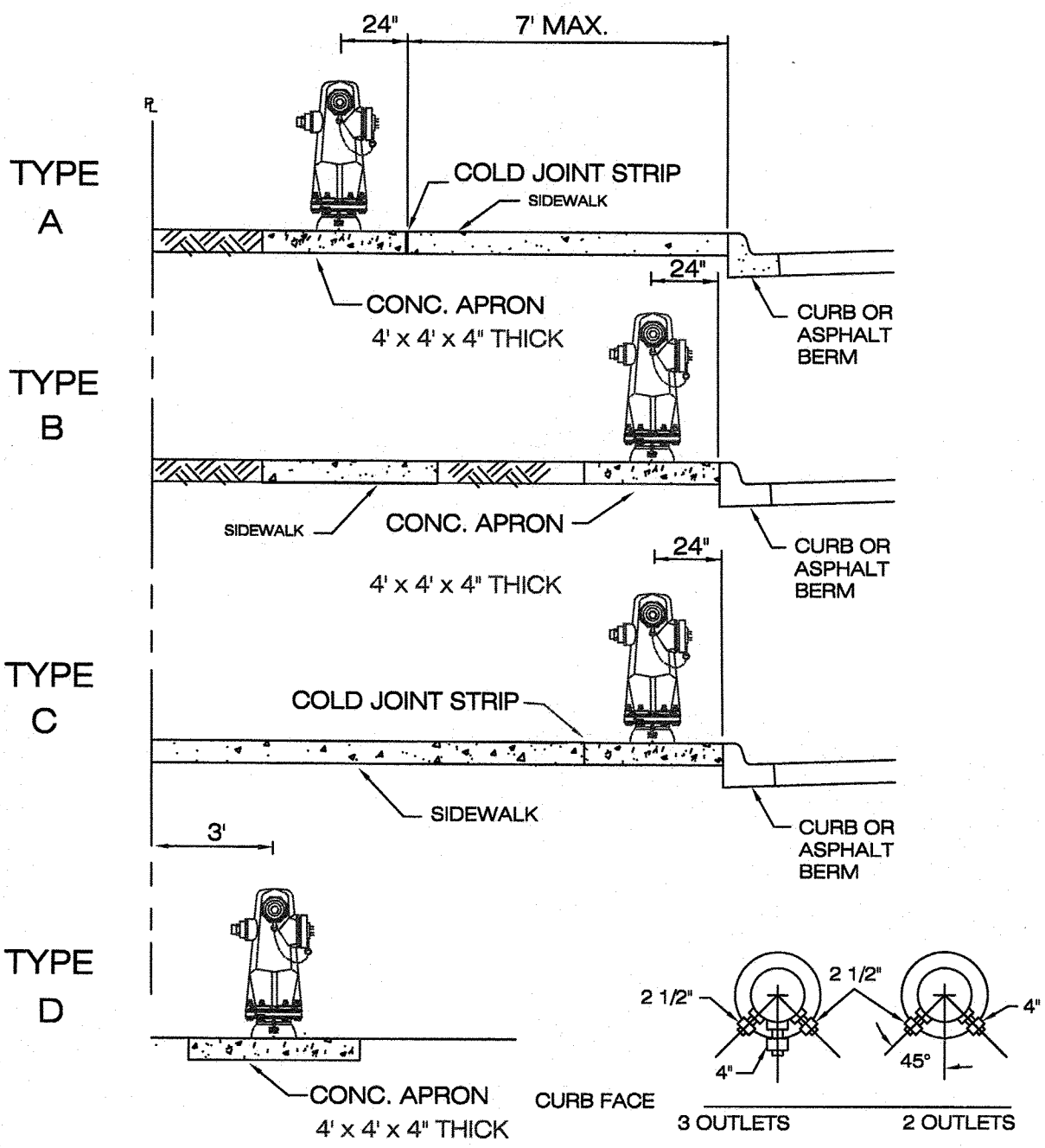

NOTES

- 1 APRON, WHERE REQUIRED
- 2 DISTANCE FROM HYDRANT TO TOP OR TOE OF SLOPE, MINIMUM 3' REQUIRED.
- 3 WHERE HYDRANT IS NOT PROTECTED BY A VERTICAL FACE CURB, PROTECTIVE POSTS MAY BE REQUIRED BY DISTRICT. SEE STD. DWG. 4-3 FOR DETAILS.
- 4 HYDRANT SHALL BE LOCATED 5' FROM CURB RETURN, 5' MIN. FROM DRIVEWAY, ON PROPERTY LINE EXTENSION, OR AS SHOWN ON PLANS.

REVISIONS	APPROVED	DATE	VISTA IRRIGATION DISTRICT
UPDATED	B. SMITH	03/25/11	FIRE HYDRANT LOCATIONS
UPDATED	B. SMITH	12/10/12	
<div style="display: flex; justify-content: space-between;"> <i>Brian Smith</i> 12/10/12 </div>			
<div style="display: flex; justify-content: space-between;"> BRIAN SMITH DATE </div>			
<div style="display: flex; justify-content: space-between;"> R.C.E. 39926 </div>			
STD. DWG. 4-2			

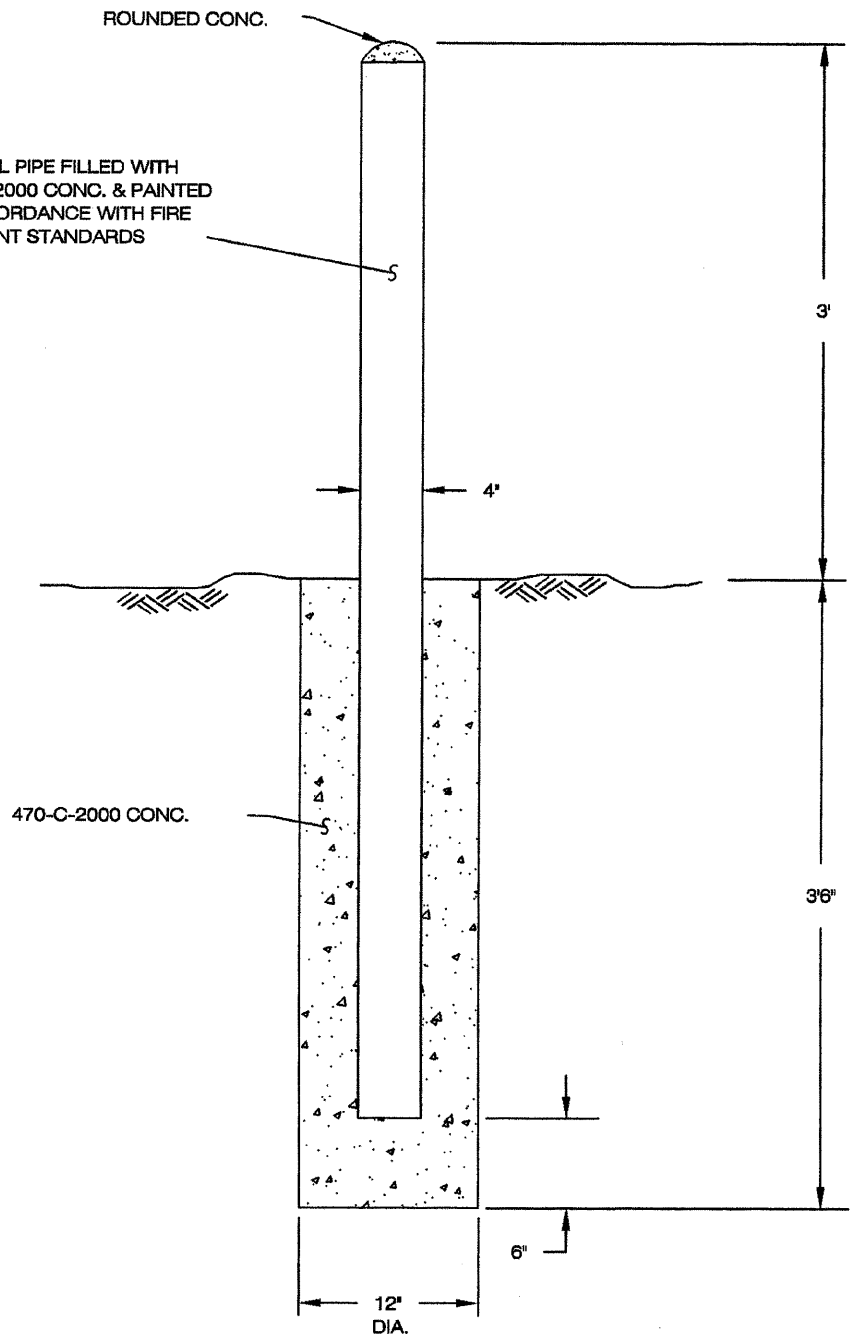

NOTE: REQUIRED BY DISTRICT OR FIRE DEPT. AS NEEDED.

REVISIONS	APPROVED	DATE	VISTA IRRIGATION DISTRICT	PATH: (TOM) H:\STDDWGS\4-3.DWG
			PROTECTION POST	<i>John A. Amodeo</i> 12/2/97
				JOHN AMODEO DATE
				R. C. E. 31161
				STANDARD DRAWING 4-3
ACAD		6/96		

CONDITION A-FIRE CONNECTION WITHIN PUBLIC RIGHT OF WAY

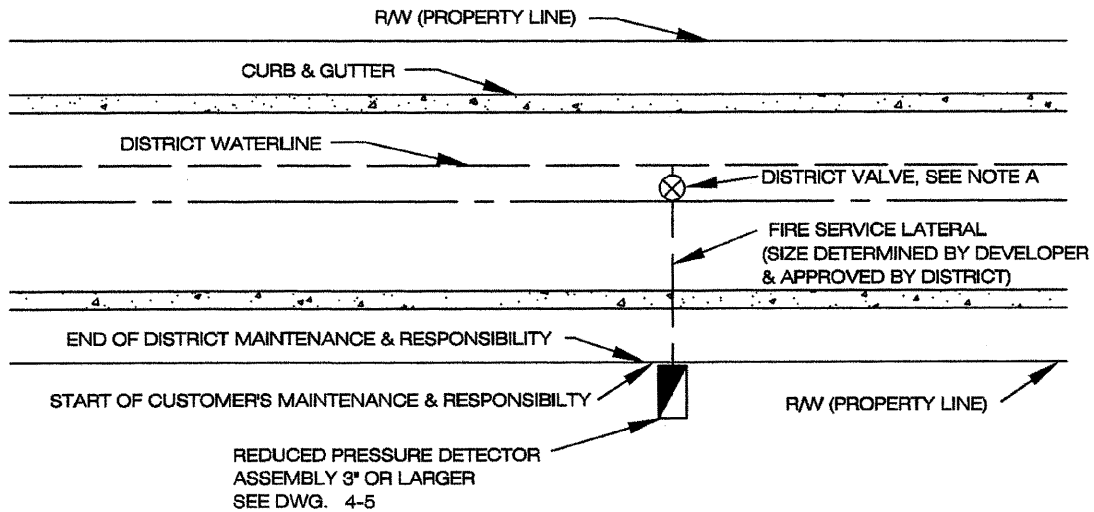

CONDITION B-FIRE CONNECTION WITHIN DISTRICT EASEMENT

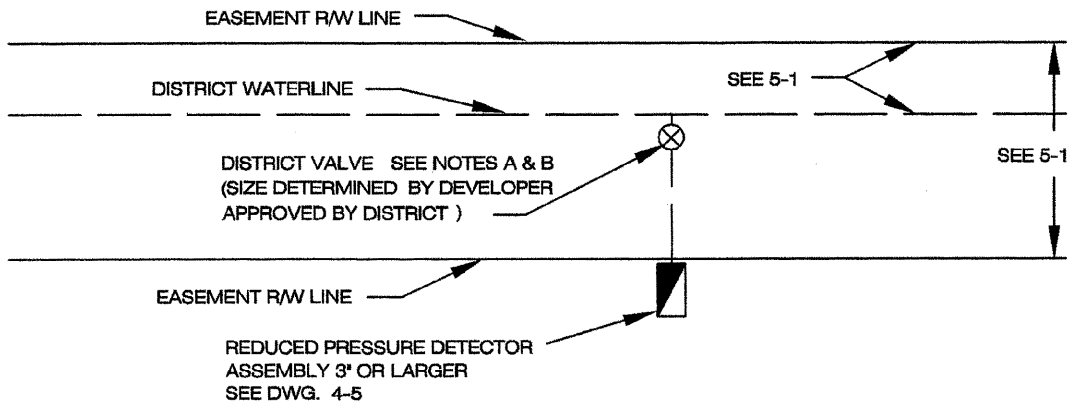

NOTE

- A DISTRICT VALVE TO BE OPERATED SOLELY BY DISTRICT. CUSTOMER TO NOTIFY DISTRICT TO CLOSE VALVE WHEN REQUIRED FOR MAINTENANCE OF CUSTOMER'S SYSTEM.
- B DISTRICT MAINTENANCE AND RESPONSIBILITY TERMINATES AT DOWNSTREAM SIDE OF VALVE AND CUSTOMER'S MAINTENANCE AND RESPONSIBILITY BEGINS.
- C DISTRICT WILL INSPECT UNDERGROUND INSTALLATION OF ALL FIRE CONNECTIONS BETWEEN DISTRICT GATE VALVE AND RPDC ASSEMBLY.
- D MATERIALS USED UP TO AND INCLUDING THE RPDC ASSEMBLY ARE TO MEET DISTRICT SPECIFICATIONS.

REVISIONS	APPROVED	DATE	VISTA IRRIGATION DISTRICT	PATH: (TOM) H:\STDDWGS\4-4.DWG
			FIRE SERVICE CONNECTIONS	<i>John A. Amodeo</i> (2/2/97) JOHN AMODEO R. C. E. 31161
				DATE
				STANDARD DRAWING 4-4
ACAD		6/96		

END OF DISTRICT MAINTENANCE RESPONSIBILITY PER. STD DWG. 4-4

VARIES WITH SIZE & MAKE

END OF DISTRICT INSPECTION

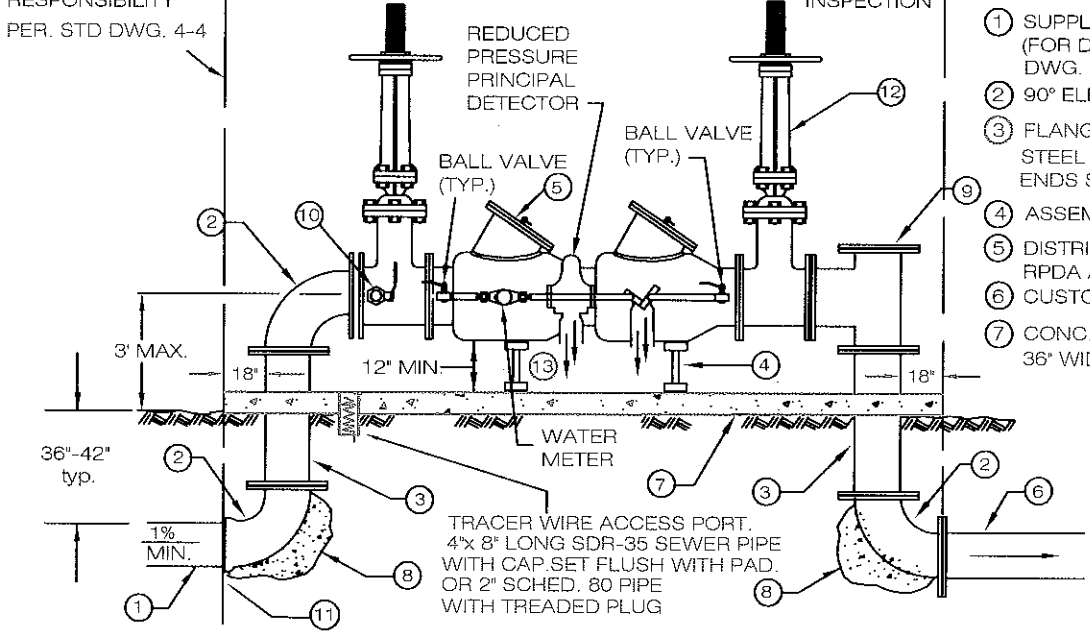

- ① SUPPLY LINE (FOR DETAILS SEE DWG. 4-4)
- ② 90° ELBOW
- ③ FLANGED DUCTILE IRON OR STEEL CML&C SPOOL BOTH ENDS SHALL BE FLANGED
- ④ ASSEMBLY SUPPORT
- ⑤ DISTRICT APPROVED RPDA ASSEMBLY
- ⑥ CUSTOMER LINE
- ⑦ CONC. SPLASH PAD (MIN. 4" THICK 36" WIDE AS REQUIRED)

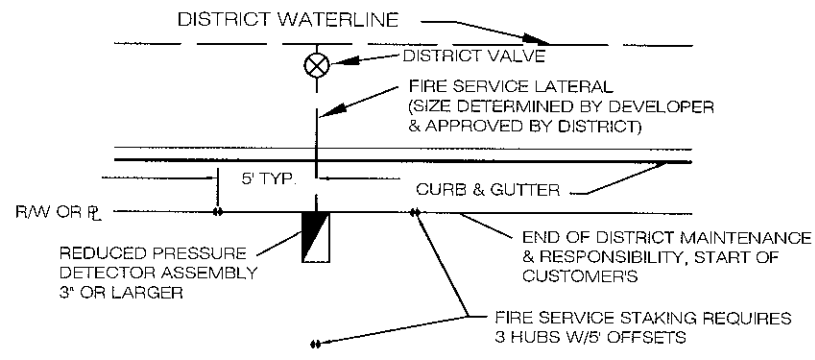

- ⑧ CONC. THRUST BLOCK PER STD DWG. 5-7
- ⑨ FIRE DEPT. CONNECTION, IF REQUIRED
- ⑩ TEST PORT
- ⑪ FLANGE OR FLANGE ADAPTER (FOR STEEL PIPE SERVICE LINE, INSULATION KIT ASSEMBLY REQUIRED PER DWG. 8-10)
- ⑫ OS&Y R/W GATE VALVES

NOTE: ALL JOINTS CAN BE WELDED IN LIEU OF FLANGES

- ⑬ INSTALL FIRE SERVICE SO THAT THE DISTANCE BETWEEN THE BOTTOM OF RELIEF DIAPHRAGM AND THE CONCRETE SLAB OR FINISH GRADE IS 12" MINIMUM AND 24" MAX.

STAKING REQUIREMENTS FOR FIRE SERVICES

NOTES:

- 1 THE REDUCED PRESSURE DETECTOR ASSEMBLY SHALL BE SELECTED FROM THE USC LIST OF APPROVED BACKFLOW DEVICES.
- 2 SPECIFIC INSTALLATION SHALL BE SUBMITTED TO DISTRICT FOR APPROVAL OF LOCATION OF DEVICE
- 3 PROPERTY OWNER IS RESPONSIBLE TO MAINTAIN AND REPAIR THE RPDA, BY-PASS ASSEMBLY AND WATER METER.
- 4 PROPERTY OWNER IS REQUIRED TO HAVE THE DEVICE TESTED ANNUALLY BY A CERTIFIED TESTER, WITH A COPY OF THE RESULTS SENT TO DISTRICT.
- 5 METER REGISTER TO BE IN CUBIC FEET.
- 6 CONTACT FIRE DEPARTMENT FOR OTHER REQUIREMENTS.
- 7 (24") MINIMUM CLEARANCE SHALL BE MAINTAINED ALL AROUND PAD WHEN INSTALLED WITH OR BY A WALL OR ANY OTHER OBSTRUCTIONS.

"ALL INSTALLATIONS SHALL MEET THE MINIMUM REQUIREMENT OF THE UNIFORM PLUMBING CODE"

REVISIONS	APPROVED	DATE	VISTA IRRIGATION DISTRICT	
UPDATED	B. SMITH	03/25/11	FIRE SERVICE CONNECTION REDUCED PRESSURE DETECTOR ASSEMBLY 3" OR LARGER	3/25/11 BRIAN SMITH DATE R.C.E. 39926
				STD. DWG. 4-5

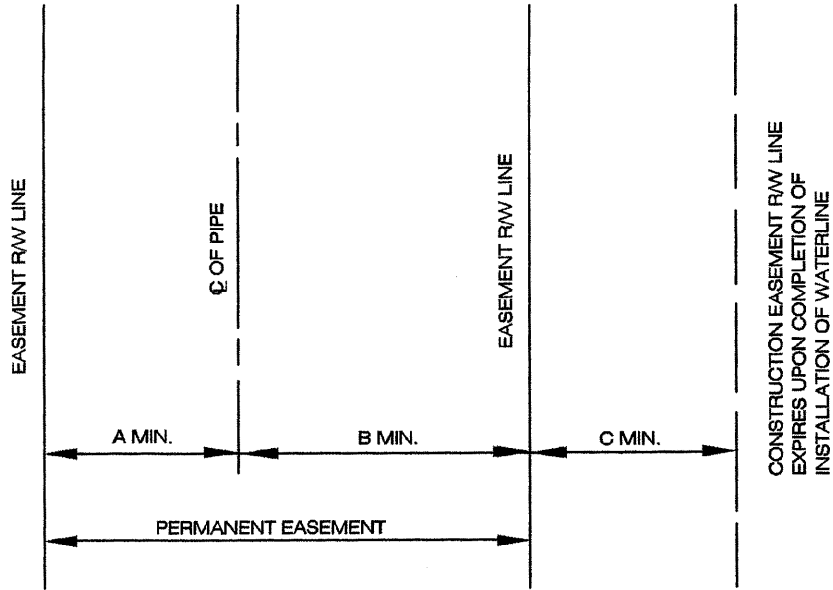

NOTES:

1. DIMENSIONS A, B AND C ARE MINIMUM WIDTHS AND ONLY APPLY TO PIPE INSTALLATIONS WITH A MAXIMUM COVER OF 36" TO TOP OF PIPE.
2. EASEMENT WIDTHS MAY INCREASE AND THE DISTRICT WILL REVIEW FOR PROJECTS REQUIRING MORE THAN 36" OF COVER TO TOP OF PIPE OR IF EASEMENTS ARE WITHIN CROSS SLOPES OF GREATER THAN 6%.
3. MAXIMUM CROSS-SLOPE @ 10%

REQUIRED EASEMENT WIDTHS			
SIZE OF PIPE	A	B	C
THRU 10"	6'	14'	10'
12" THRU 18"	7'	23'	10'
20" THRU 36"	12'	18'	20'
ABOVE 36"	DISTRICT TO REVIEW		

REVISIONS	APPROVED	DATE	VISTA IRRIGATION DISTRICT	PATH: (TOM) H:\STDDWGS\5-1.DWG
			STANDARD EASEMENT WIDTHS	<i>John A. Amodeo</i> 12/2/98
				JOHN AMODEO R. C. E. 31161
ACAD		6/96		STANDARD DRAWING 5-1

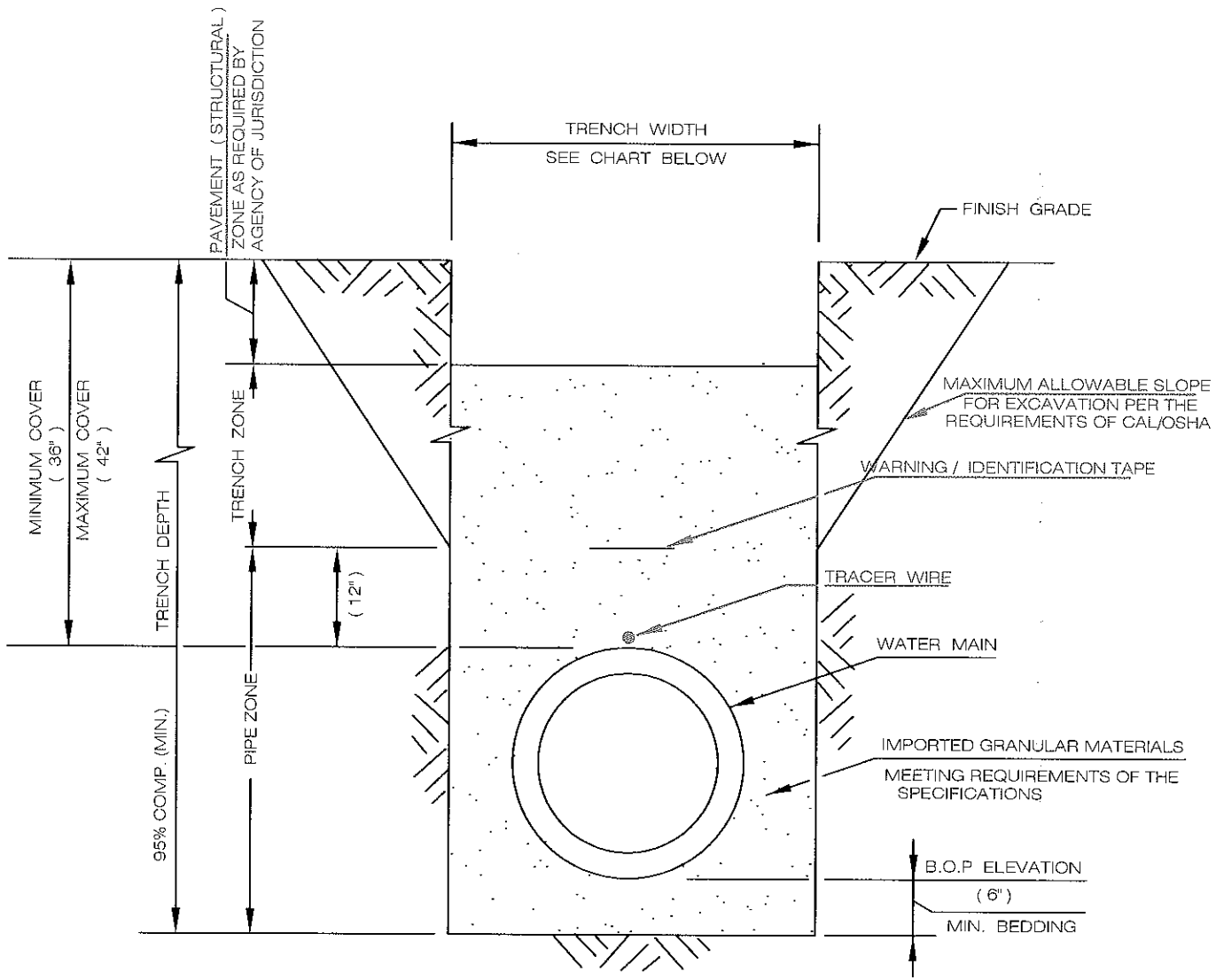

TRENCH SECTION

NOTES

- 1 PAVING OR PAVEMENT REPAIR TO BE DONE IN ACCORDANCE TO CITY OR COUNTY STANDARDS
- 2 EXCAVATE BELL HOLES AT EACH PIPE JOINT TO PERMIT PROPER ASSEMBLY AND INSPECTION OF THE ENTIRE JOINT.
- 3 UNLESS OTHERWISE SHOWN ON PLANS, COVER OVER PIPE SHALL BE 36" TO 42" OR AS DIRECTED BY THE ENGINEER.
- 4 ALL PIPE LINE TRENCHES SHALL BE EXCAVATED SO THAT THE DISTANCE BETWEEN TRENCH WALLS AT THE TOP OF PIPE SHALL BE AS SHOWN BELOW:

TRENCH WIDTH

NOMINAL PIPE INSIDE DIAMETER	MINIMUM DISTANCE	MAXIMUM DISTANCE
(4") & SMALLER	(18")	(28")
(6" & 8")	(24")	(32")
(10" & 12")	(28")	(36")
(16" THRU 36")	OD PLUS (24")	OD PLUS (36")

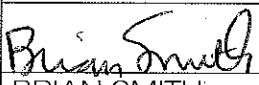
REVISIONS	APPROVED	DATE	VISTA IRRIGATION DISTRICT	 BRIAN SMITH R.C.E. 39926	3/25/11 DATE
UPDATED	B. SMITH	03/25/11			
			PIPE BEDDING AND TRENCH BACKFILL FOR WATER MAINS	STD. DWG. 5-2	

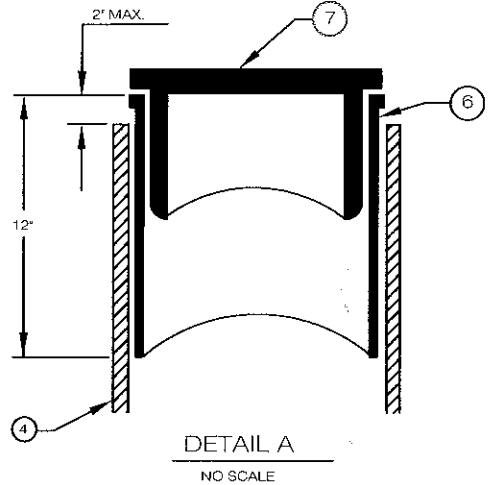
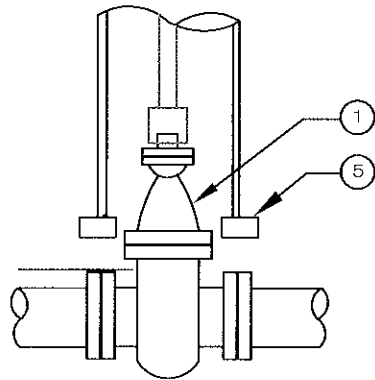
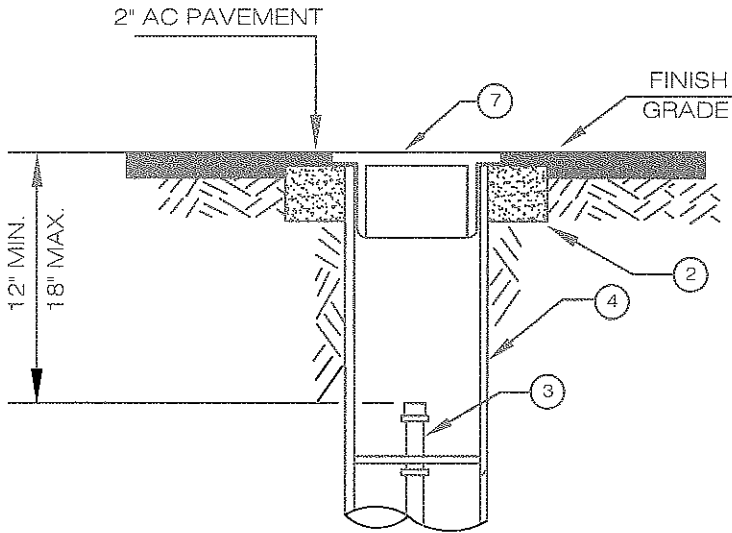

TOP VIEW

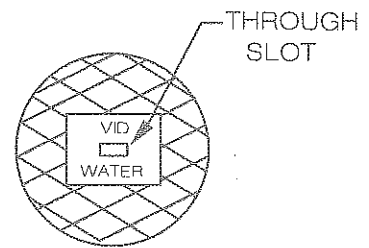

NOTES

- 1 PIPE SHALL BE SAW OR MACHINE CUT ON EACH END, NO BEVELED OR BELL SECTIONS
- 2 FOR INLINE VALVE ANCHOR BLOCK INSTALLATION SEE STD. DWG. 5-5
- 3 VALVES DEEPER THAN 5' REQUIRE A VALVE STEM EXTENSION
- 4 EXTENSION STEMS SHALL NOT BE ATTACHED / BOLTED TO OPERATING NUT
- 5 MATERIALS SHALL BE SELECTED FROM THE VID APPROVED MATERIAL LIST

ITEM NO.	SIZE AND DESCRIPTION	ITEM NO.	SIZE AND DESCRIPTION
1	RESILIENT WEDGE GATE VALVE	4	8" PVC DR-14 PIPE x REQUIRED LENGTH OF GATE WELL
2	6" HIGH x 6" WIDE COMPACTED ASPHALT-CONCRETE RING	5	SUPPORT WITH (2) 2" x 2" x 12" LONG REDWOOD BLOCKS OR THE CONCRETE VALVE BLOCKING
3	VALVE STEM EXTENSION SEE NOTES 3 & 4	6	12" x 8" GALVANIZED SLEEVE, 20 GAUGE
		7	8" x 6" GATE WELL LID SEE APPROVED VID MATERIAL LIST

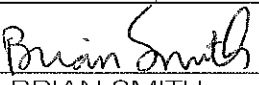
REVISIONS	APPROVED	DATE	VISTA IRRIGATION DISTRICT	
UPDATED	B. SMITH	3/25/11	VALVE WELL INSTALLATION	 3/25/11 BRIAN SMITH DATE R.C.E. 39926
				STD. DWG. 5-3

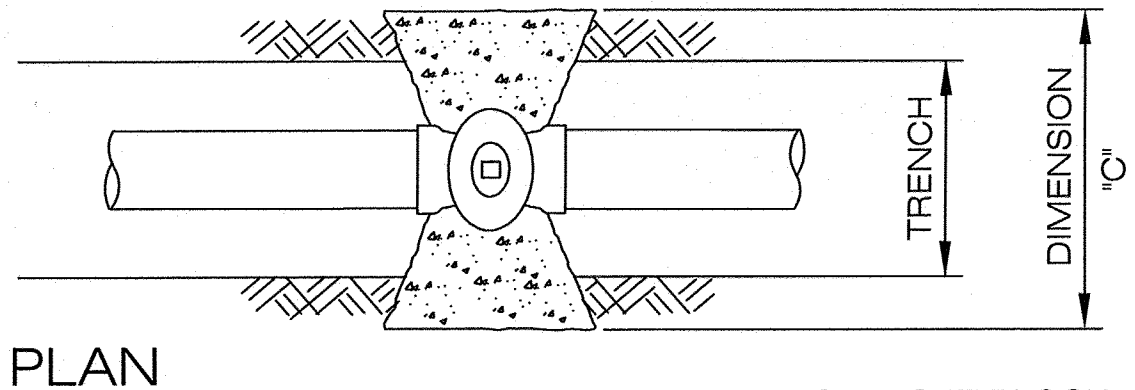
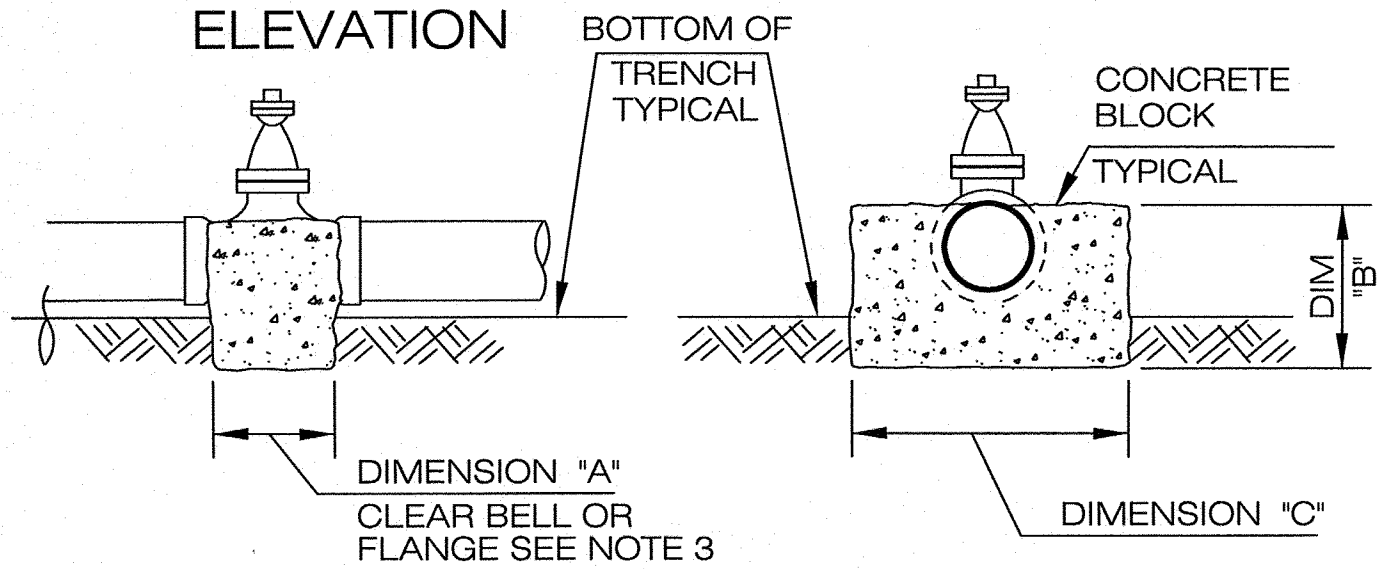

VALVE SUPPORT BLOCK

VALVE SIZE	DIMENSION "A"	DIMENSION "B"
4" & 6"	12"	12"
8"	13"	14"
10"	14"	16"
12"	15"	18"

DIMENSION "C" = TRENCH WIDTH PLUS TWO TIMES THE PIPE DIAMETER

FIGURES SHOWN ARE MINIMUMS ONLY

NOTES

- 1 SUPPORT BLOCKS ARE NOT INTENDED TO PROVIDE THRUST RESTRAINT WHEN VALVES ARE OPERATED. IN LOCATIONS WHERE VALVES ARE NOT LOCATED ADJACENT TO PIPE FITTINGS OR ARE OTHERWISE NOT PROVIDED WITH THRUST RESTRAINT, THRUST BLOCKS ARE REQUIRED INSTEAD OF SUPPORT BLOCKS.
- 2 CONCRETE REFER TO SECTION 3000 OF SPECIFICATION.
- 3 ALL VALVES REQUIRE SUPPORT BLOCKS. CONCRETE SHALL BE POURED AGAINST WETTED UNDISTURBED SOIL AND PLACED SO THAT VALVES WILL BE ACCESSIBLE FOR REPAIRS OR REPLACEMENT.

REVISIONS	APPROVED	DATE	VISTA IRRIGATION DISTRICT		
UPDATED	B. SMITH	04/11/13	CONCRETE VALVE BLOCKING	<i>Brian Smith</i> 4/11/13	
				BRIAN SMITH	DATE
				R.C.E. 39926	
				STD. DWG. 5-5	

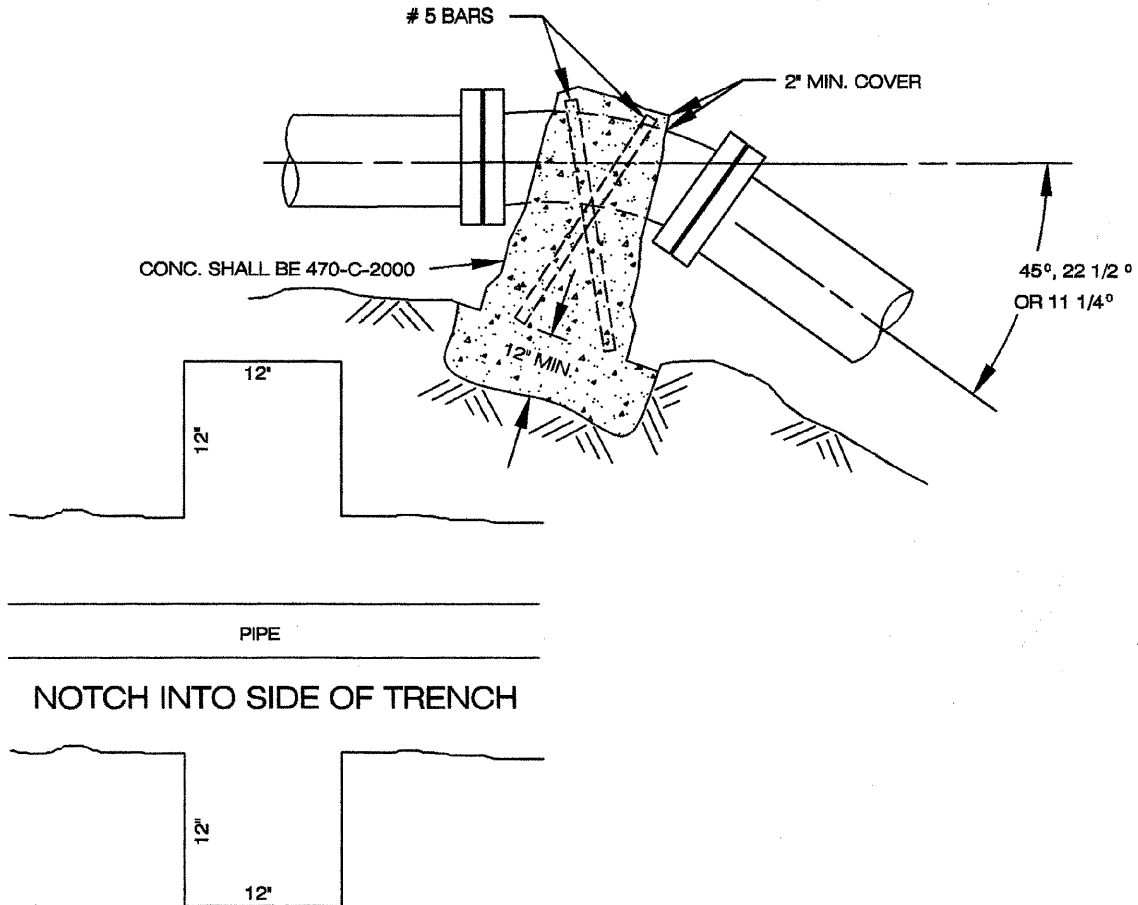

NOMINAL PIPE DIA.	CUBIC FT. OF CONCRETE REQUIRED PER 100 PSI PRESSURE		
	45°	22 1/2°	11 1/4°
4	7	4	2
6	15	8	4
8	27	14	7
10	**	21	11
12	**	**	16

* INCREASE VOLUMES SHOWN IN PROPORTIONS TO PRESSURES
EXISTING WHEN PRESSURE TESTING PIPELINE.

** SPECIAL DESIGN REQUIRED.

REVISIONS	APPROVED	DATE	VISTA IRRIGATION DISTRICT	PATH: (TOM) H:\STDDWGS\5-6.DWG
			ANCHOR BLOCK (VERTICAL BEND ONLY)	<i>John A. Amodeo</i> 12/2/95
				JOHN AMODEO R. C. E. 31161
ACAD		6/96		STANDARD DRAWING 5-6

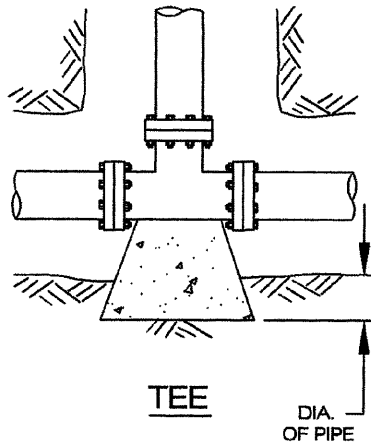

TEE

DIA.
OF PIPE

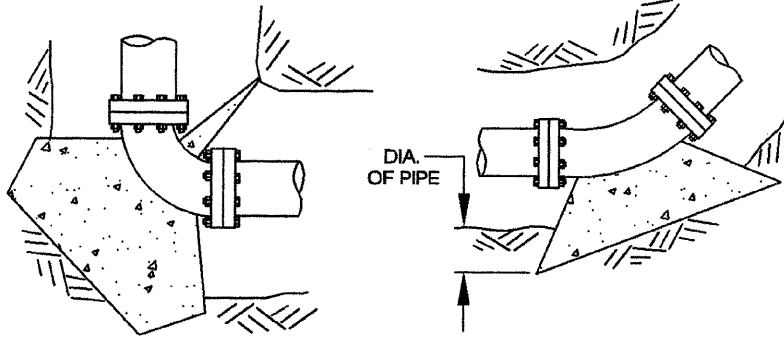

HOR. OR VER.
BENDS

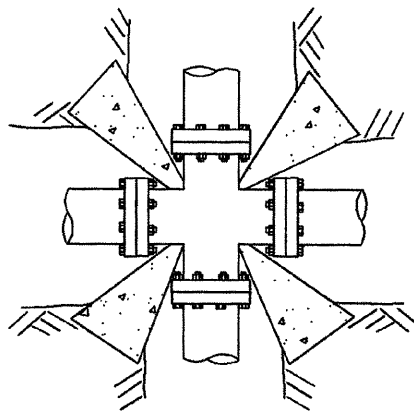

CROSS BLOCKING

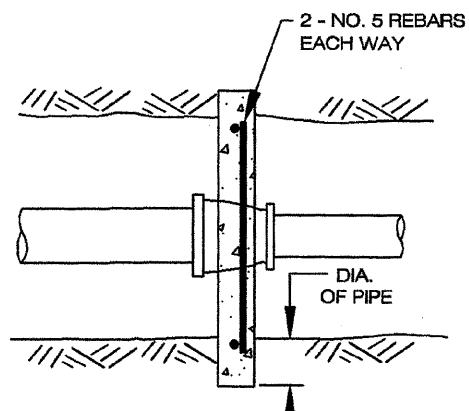

REDUCER

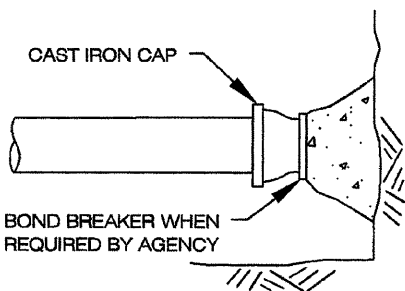

PVC PIPE
ELEVATION

DEAD END BLOCKING

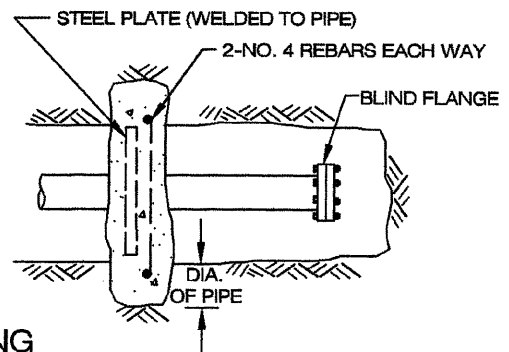

STEEL PIPE PLAN

- NOTES:
1. CONC. SHALL BE 470-C-2000
 2. SEE STD. DWG. 5-8 FOR BEARING AREAS
 3. BEARING AREAS TO BE FLAT AND CORNERS SQUARE.

REVISIONS	APPROVED	DATE	VISTA IRRIGATION DISTRICT	PATH: (TOM) H:\STDDWGS\5-7.DWG
			<p>CONCRETE THRUST BLOCKS</p>	<p><i>John A. Amodeo 12/2/95</i></p> <p>JOHN AMODEO DATE</p> <p>R. C. E. 31161</p>
				<p>STANDARD DRAWING 5-7</p>
ACAD		6/96		

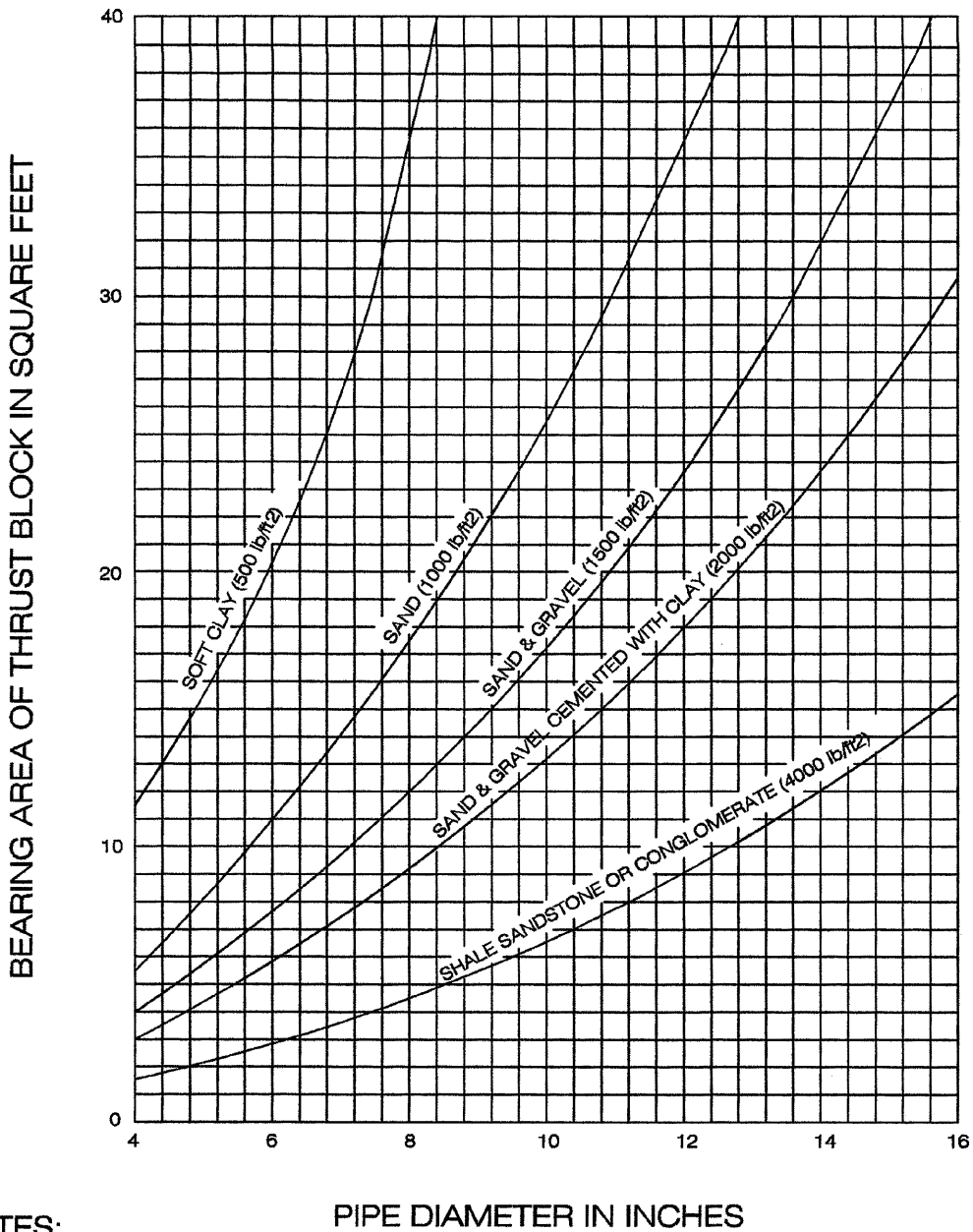

NOTES:

- 1 BASED ON 225 PSI TEST PRESSURE AND BEARING VALUES OF DRY SOIL
- 2 VALUES FROM CURVES ARE FOR TEES AND DEADENDS, I.E.; STRAIGHT LINE THRUST
 FOR 90° BEND 1.4 VALUE FROM CURVE
 FOR 45° BEND 0.8 VALUE FROM CURVE
 FOR 22 1/2° BEND; 0.4 VALUE FROM CURVE
- 3 FOR CONDITIONS NOT COVERED BY CURVES, SPECIAL THRUST BLOCKS MUST BE COMPUTED AND APPROVED

REVISIONS	APPROVED	DATE	VISTA IRRIGATION DISTRICT	PATH: (TOM) H:\STDDWGS\5-8.DWG
			THRUST BLOCK BEARING AREAS	<i>John A. Amodeo</i> 12/2/79
				JOHN AMODEO R. C. E. 31161
ACAD		6/98		STANDARD DRAWING 5-8

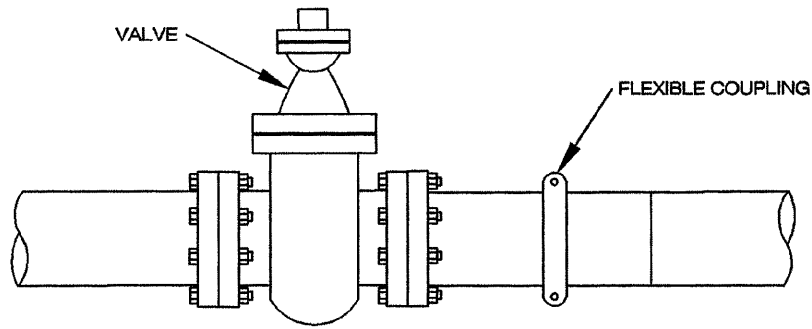

14" & LARGER STEEL MAIN

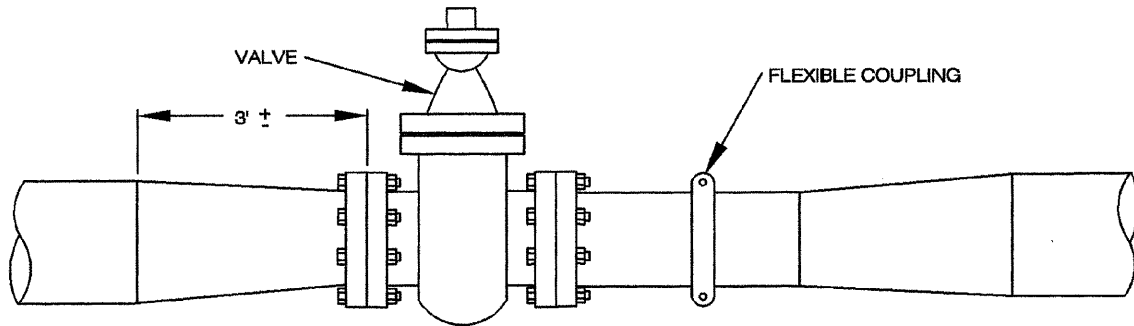

18" & LARGER STEEL MAIN

PIPE DIA.	VALVE SIZE
18"	16"
20"	18"
24"	20"
30"	24"
36"	30"
42"	36"
48"	42"

NOTES:

1. VALVE AND REDUCERS MUST BE PURCHASED TOGETHER,
2. REDUCERS MATERIAL MUST BE THE SAME AS THE PIPELINE MATERIAL

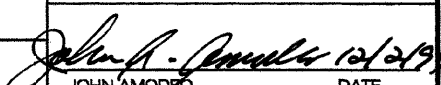
REVISIONS	APPROVED	DATE	VISTA IRRIGATION DISTRICT	PATH: (TOM) H:\STDDWGS\5-9.DWG
			VALVE SIZING FOR STEEL MAINS	 JOHN AMODEO R. C. E. 31161
				DATE
				STANDARD DRAWING 5-9
ACAD		6/96		

NOM. DIA.	ELBOWS						
	2 PIECE 0-22.5 DEG.		3 PIECE 22.5-45 DEG.		4 PIECE 45-67.5 DEG.		5 PIECE 6.75-90 DEG.
	M	R/2	N	R/3	P	R/4	Q OR R/5
4	9	45	12	30	15	23	19
6	9	45	13	32	16	24	21
8	10	50	14	35	18	27	24
10	10	50	15	37	20	30	26
12	11	55	16	40	22	33	29
14	11	55	17	42	24	36	31
16	12	60	18	44	26	40	34
18	12	60	19	47	27	41	36
20	13	65	20	49	28	42	39
22	13	65	21	51	30	45	41
24	14	70	22	54	32	48	44
30	15	75	25	61	37	51	51
36	16	80	27	66	40	60	56
42	17	85	28	69	42	63	59
48	17	85	29	71	44	66	61
54	18	90	30	74	46	69	63
60	18	90	31	76	48	72	65

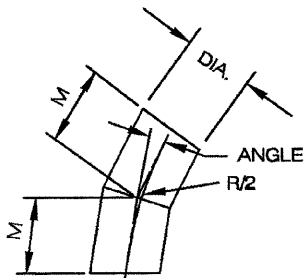

2 PIECE
ELBOW
0-22.5 deg.

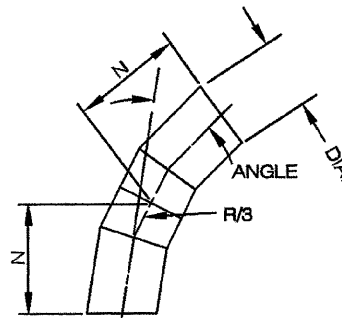

3 PIECE
ELBOW
22.5-45 deg.

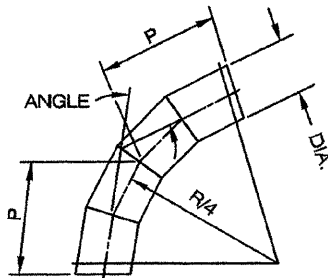

4 PIECE
ELBOW
45-67.5 deg.

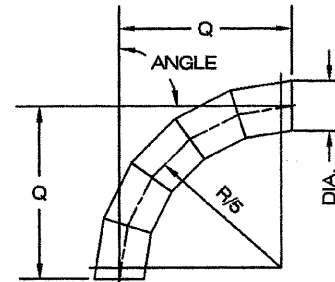

5 PIECE
ELBOW
67.5-90 deg.

REVISIONS	APPROVED	DATE	VISTA IRRIGATION DISTRICT	PATH: (TOM) H:\STDDWGS6-1.DWG
			STEEL WATER PIPE ELBOW DESIGNS	<i>John A. Amodeo</i> 12/2/99
				JOHN AMODEO R. C. E. 31161
ACAD		6/96		STANDARD DRAWING 6-1

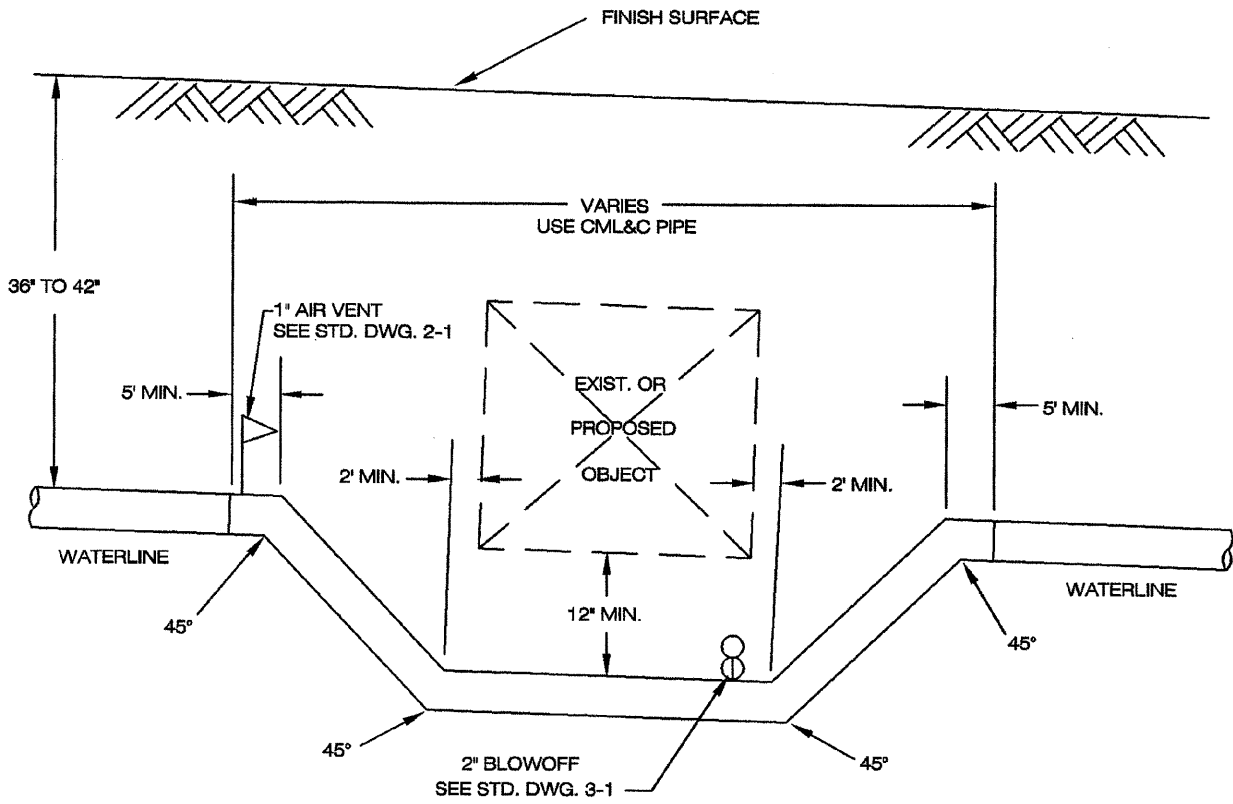

NOTES

- A. TO BE USED ONLY WHEN 6-3 IS NOT APPROVED BY DISTRICT.
- B. CHANGES IN DESIGN TO BE APPROVED BY DISTRICT AND DETAIL TO BE SHOWN ON IMPROVEMENT PLANS.
- C. BLOW-OFF REQUIRED AT LOW POINT, SIZE TO BE DETERMINED BASED UPON SIZE OF LINE.
- D. THRUST BLOCKS MAY BE REQUIRED DUE TO FIELD CONDITIONS.
- E. CATHODIC PROTECTION ANODES AND TEST STATIONS REQUIRED AT EACH END OF CROSSING. SEE STD. DWG. 8-13
- F. WHEN BIDDING, PRICE NOT TO INCLUDE BLOW-OFF OR AIR-VENT ASSEMBLY.

REVISIONS	APPROVED	DATE	VISTA IRRIGATION DISTRICT	PATH: (TOM) H:\STDDWGS\6-2.DWG
			STANDARD CROSSING (UNDER PROPOSED OBJECT)	<i>John A. Amodeo</i> 12/2/95 JOHN AMODEO DATE
				R. C. E. 31161
ACAD		6/96		STANDARD DRAWING 6-2

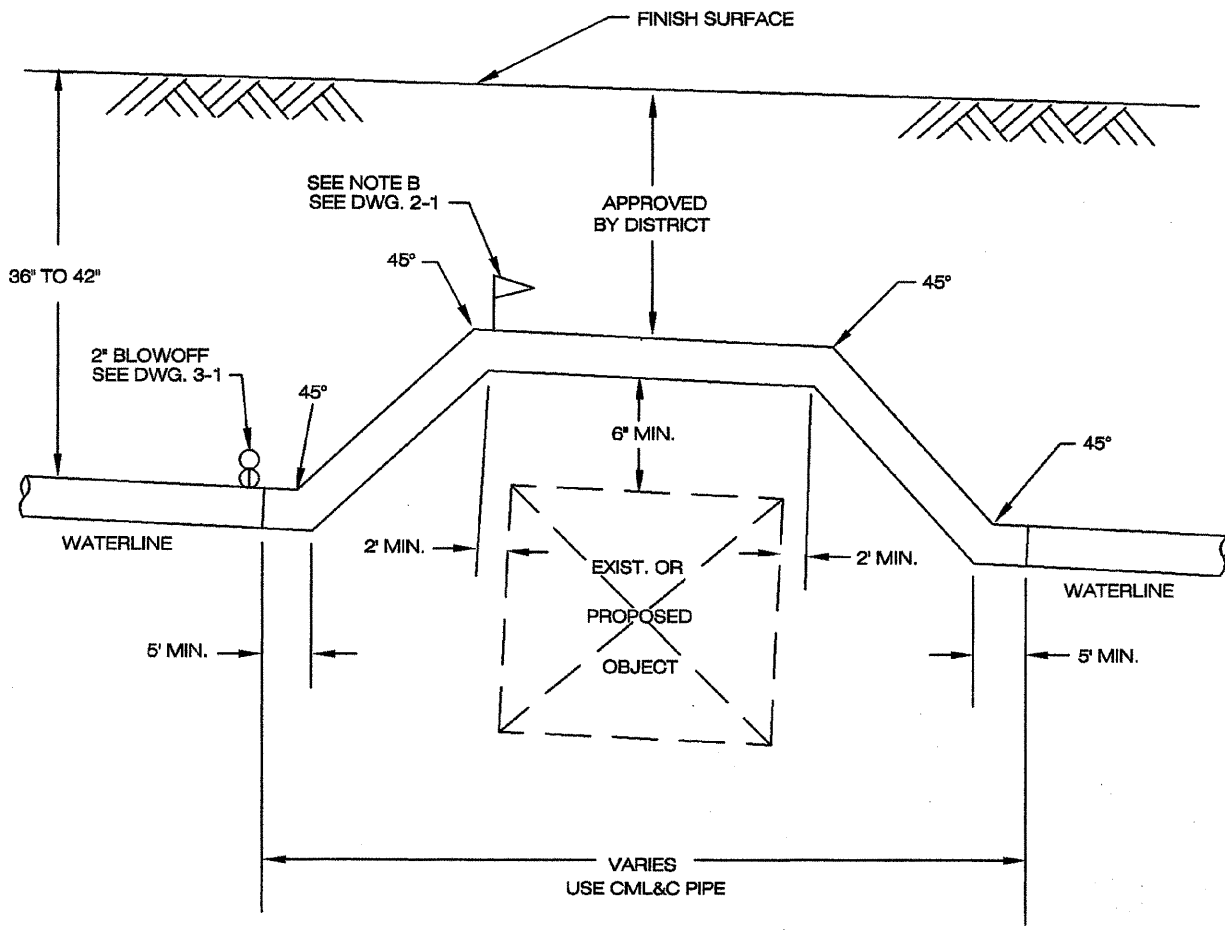

NOTES

- A. WHEN BIDDING, PRICE NOT TO INCLUDE AIR VENT & BLOW-OFF
- B. AIR VENT REQUIRED BY HIGH POINT, SIZE TO BE DETERMINED BY SIZE OF LINE.
- C. THRUST BLOCKS MAY BE REQUIRED DUE TO FIELD CONDITIONS.
- D. CATHODIC PROTECTION ANODES AND TEST STATIONS REQUIRED AT EACH END OF CROSSING. SEE STD. DWG. 8-13
- E. 18" COVER REQUIRES MIN. 1/4" WALL THICKNESS
- F. 24" COVER REQUIRES MIN. 3/16" WALL THICKNESS
- G. GREATER THAN 24" COVER REQUIRES MIN. 1/8" WALL THICKNESS.

REVISIONS	APPROVED	DATE	VISTA IRRIGATION DISTRICT	PATH: (TOM) H:\STDDWGS\6-3.DWG
			STANDARD CROSSING (ABOVE PROPOSED OBJECT)	<i>John A. Amodeo</i> 12/2/95 JOHN AMODEO DATE
				R. C. E. 31161
ACAD		6/96		STANDARD DRAWING 6-3

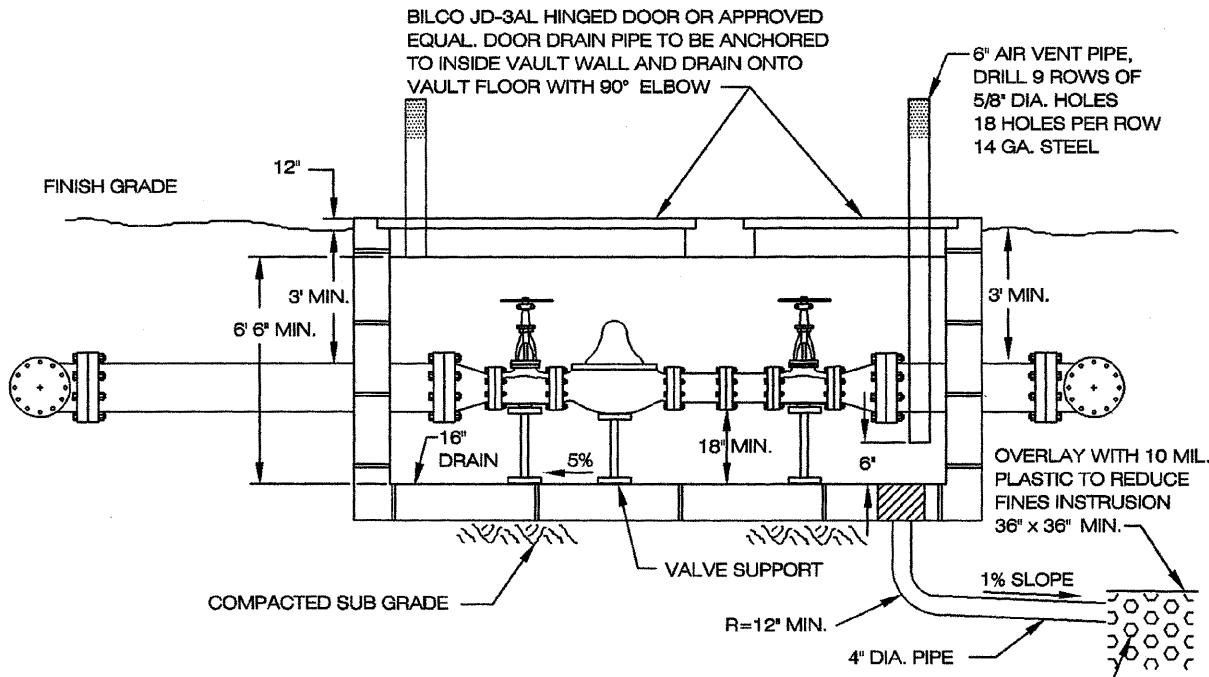
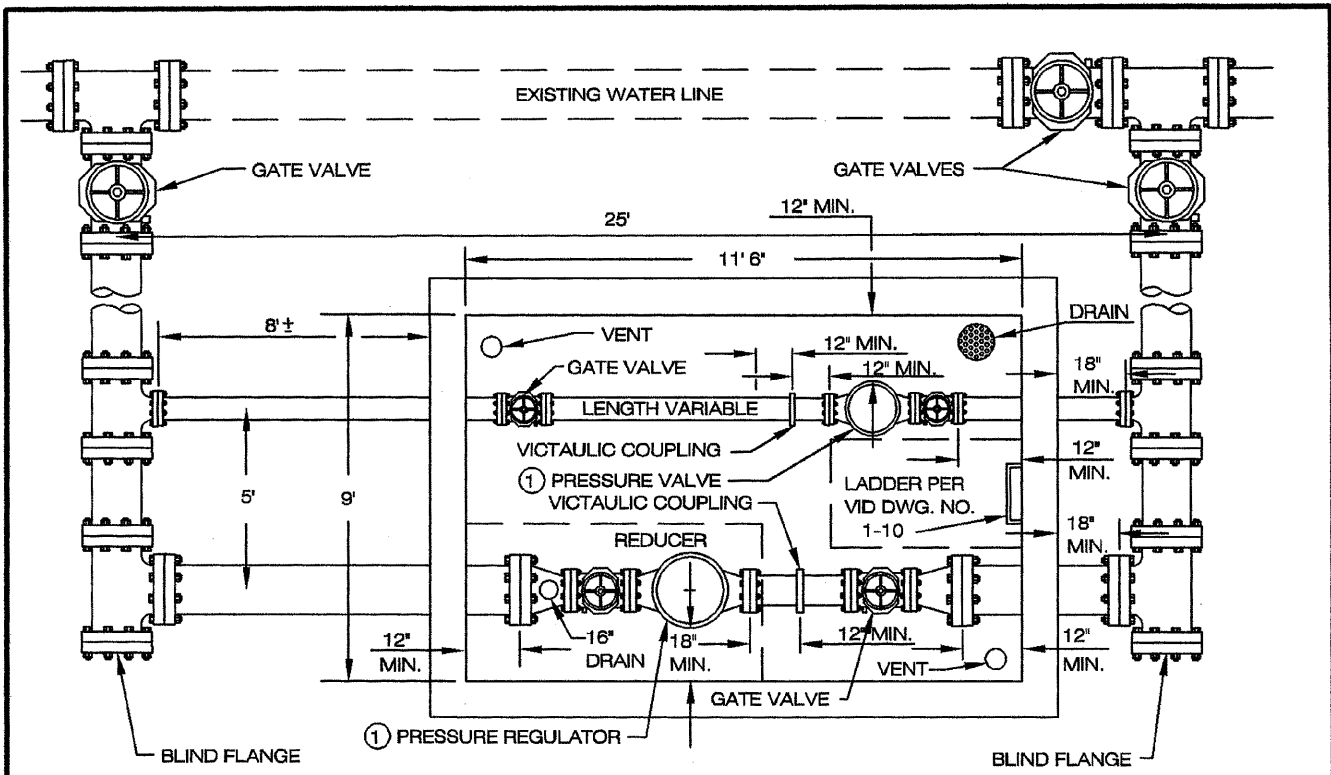

- 1 CLAYTON 90G-01AB PRESSURE REDUCING VALVE OR APPROVED EQUAL (WITH EPOXY COATING AND S.S. TRIM)
- 2 ALL PIPING C.M.L.&C. STEEL PIPE 3/16"
- 3 ALL TEES, REDUCERS, VALVES, ETC. PER VID APPROVED MATERIALS TEST.

OVERLAY WITH 10 MIL. PLASTIC TO REDUCE FINES INTRUSION 36" x 36" MIN.

1% SLOPE

4" DIA. PIPE

24" x 24" x 24" SUMP WITH 3/4" GRAVEL (ACTUAL LOCATION TO BE DETERMINED IN FIELD)

REVISIONS	APPROVED	DATE	VISTA IRRIGATION DISTRICT	PATH: (TOM) H:\STDDWGS\6-6.DWG
			PRESSURE REDUCTION STATION	 JOHN AMODEO R. C. E. 31161
ACAD		6/96	STANDARD DRAWING	6-4

PARALLEL CONSTRUCTION

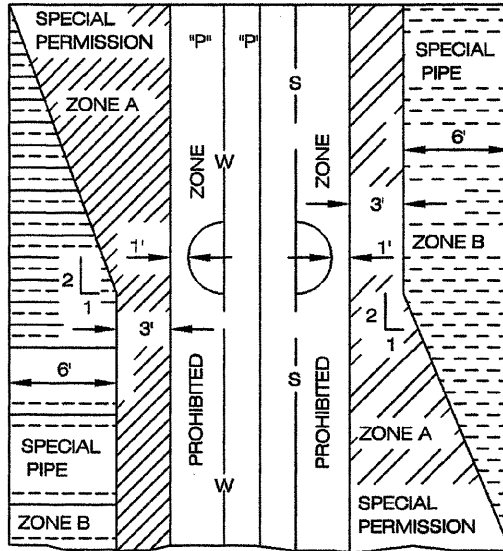

NOTES
 ZONE IDENTICAL ON SIDES OF CENTER LINES.

- A. ZONE P IS A PROHIBITED ZONE, SECTION 64630(E)
- B. CALIF. ADMINISTRATIVE CODE, TITLE 22

CASE 1, NEW SEWER

CASE 2, NEW WATER MAIN

ZONE D, PIPELINES ARE NOT ALLOWED IN ZONE D WITHOUT PRIOR WRITTEN APPROVAL OF DISTRICT.

ZONE P IS A PROHIBITED CONSTRUCTION ZONE

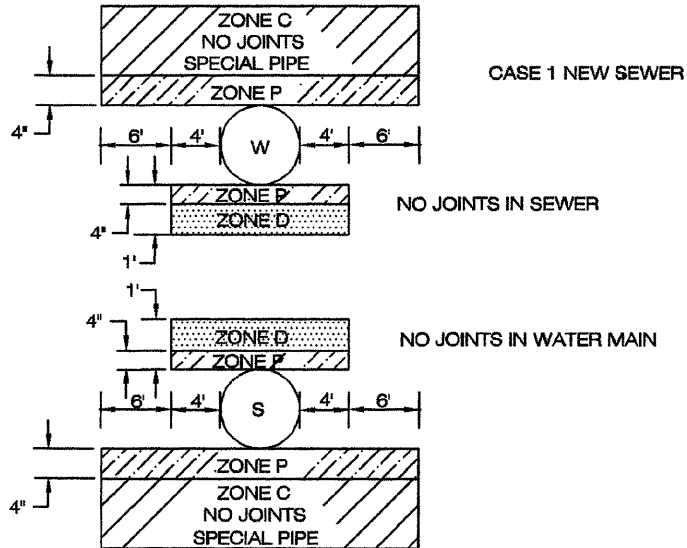

CASE 2, NEW WATER MAIN

REVISIONS	APPROVED	DATE	VISTA IRRIGATION DISTRICT	PATH: (TOM) H:\STDDWGS\7-1.DWG
			WATER LINE AND SEWER LINE SEPARATIONS	<i>John Amodeo</i> 12/2/97 JOHN AMODEO DATE R. C. E. 31161
ACAD		6/96		STANDARD DRAWING 7-1

DEPARTMENT OF HEALTH SERVICES
CRITERIA FOR THE SEPARATION OF
WATER MAINS AND SANITARY SEWERS

A: PUBLIC HEALTH CONSIDERATIONS

Waterborne disease outbreaks attributed to the entry of sewage-contaminated groundwater into the distribution systems of public water supplies continue to be a problem in the United States. A community with its buried water mains in close proximity to sanitary sewers is vulnerable to waterborne disease outbreaks.

Sanitary sewers frequently leak and saturate the surrounding soil with sewage. This is caused primarily by structural failure of the sewer line, improperly constructed joints, and subsidence or upheaval of the soil encasing the conduit. A serious public health hazard exists when the water mains are depressurized and no pressure or negative pressures occur. The hazard is further compounded when, in the course of installing or repairing a water main, existing sewer lines are broken. Sewage spills into the excavation and, hence, enters into the water main itself. Additionally, if a water main fails in close proximity to a sewer line, the resultant failure may disturb the bedding of the sewer line and cause it to fail. In the event of an earthquake or manmade disaster, simultaneous failure of both conduits often occurs.

The water supplier is responsible for the quality of the water delivered to consumers and must take all practical steps to minimize the hazard of sewage contamination to the public water supply. Protection of the quality of the water in the public water system is best achieved by the barrier provided by the physical separation of the water mains and sewer lines.

This document sets forth the construction criteria for the installation of water mains and sewer lines to prevent contamination of the public water supplies from nearby sanitary sewers.

REVISIONS	APPROVED	DATE	VISTA IRRIGATION DISTRICT	PATH: (TOM) H:\STDD\WGS7-2.DWG
			WATER LINE AND SEWER SEPARATIONS	<i>John A. Amodeo</i> 12/2/85
				JOHN AMODEO R. C. E. 31161
ACAD		6/96		STANDARD DRAWING 7-2

D. SPECIAL PROVISIONS

1. The basic separation standards are applicable under normal conditions for sewage collection lines and water distribution mains. More stringent requirements may be necessary if conditions such as high groundwater exist.
2. Sewer lines shall not be installed within 25 feet horizontally of a low head (5 psi or less pressure) water main.
3. New water mains and sewers shall be pressure tested where the conduits are located ten feet apart or less.
4. In the installation of water mains or sewer lines, measures should be taken to prevent or minimize disturbances of the existing line. Disturbance of the supporting base of this line could eventually result in failure of this existing pipeline.
5. Special consideration shall be given to the selection of pipe materials if corrosive conditions are likely to exist. These conditions may be due to soil type and/or the nature of the fluid conveyed in the conduit, such as a septic sewer which produces corrosive hydrogen sulfide.
6. SEWER FORCE MAINS
 - a. Sewer force mains shall not be installed within ten feet (horizontally) of a water main.
 - b. When a sewer force main must cross a water line, the crossing should be as close as practical to the perpendicular. The sewer force main should be at least one foot below the water line.
 - c. When a new sewer force main crosses under an existing water main, all portions of the sewer force main within ten feet (horizontally) of the water main shall be enclosed in a continuous sleeve, 1/4" thick welded steel pipe.
 - d. When a new water main crosses over an existing sewer force main, the water main shall be constructed of pipe materials with a minimum rated working pressure of 200 psi or equivalent pressure rating.

REVISIONS	APPROVED	DATE	VISTA IRRIGATION DISTRICT	PATH: (TOM) H:\STDDWGS\7-4.DWG
			WATER LINE AND SEWER SEPARATIONS	 JOHN AMODEO R. C. E. 31161
				DATE
				STANDARD DRAWING 7-4
ACAD		6/96		

E. ALTERNATE CRITERIA FOR CONSTRUCTION

The construction criteria for sewer lines or water mains where the basic separation standards cannot be attained are shown in figures 1 and 2. There are two situations encountered.

CASE 1 -- NEW SEWER LINE -- new or existing water main

CASE 2 -- NEW WATER MAIN -- existing sewer line

For CASE 1, the alternate construction criteria apply to the sewer line.

For CASE 2, the alternate construction criteria may apply to either or both the water main and sewer line.

The construction criteria should apply to the house laterals that cross ABOVE a pressure water main but not to those house laterals that cross BELOW a pressure water main.

CASE 1: NEW SEWER BEING INSTALLED (figures 1 and 2)
Zone Special Construction Required for Sewer

A Sewer line parallel to water mains shall not be permitted in this zone without approval from the responsible health agency and water supplier.

B A sewer line placed parallel to a water main shall not be constructed of:

1. Extra strength vitrified clay pipe with compression joints.
2. Class 4000, Type 2, asbestos-cement pipe with rubber gasket joints.
3. Plastic sewer pipe with rubber ring joints (per ASTM D3034) or equivalent.
4. Cast or ductile iron pipe with compression joints.
5. Reinforced concrete pressure pipe with compression joints (per AWWA C302-74).

C A sewer line crossing a water main shall be constructed of:

1. Ductile iron pipe with hot dip bituminous coating and mechanical joints.
2. A continuous section of class 200 (DR 14 per AWWA C900) plastic pipe or equivalent, centered over the pipe being crossed.
3. A continuous section of reinforced concrete pressure pipe (per AWWA C302-74) centered over the pipe being crossed.
4. Any sewer pipe within a continuous sleeve.

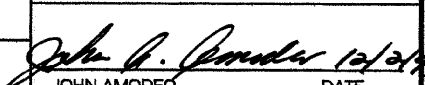
REVISIONS	APPROVED	DATE	VISTA IRRIGATION DISTRICT	PATH: (TOM) H:\STDDWGS\7-5.DWG
			WATER LINE AND SEWER SEPARATIONS	 JOHN AMODEO R. C. E. 31161
				DATE
				STANDARD DRAWING
ACAD		6/96		7-5

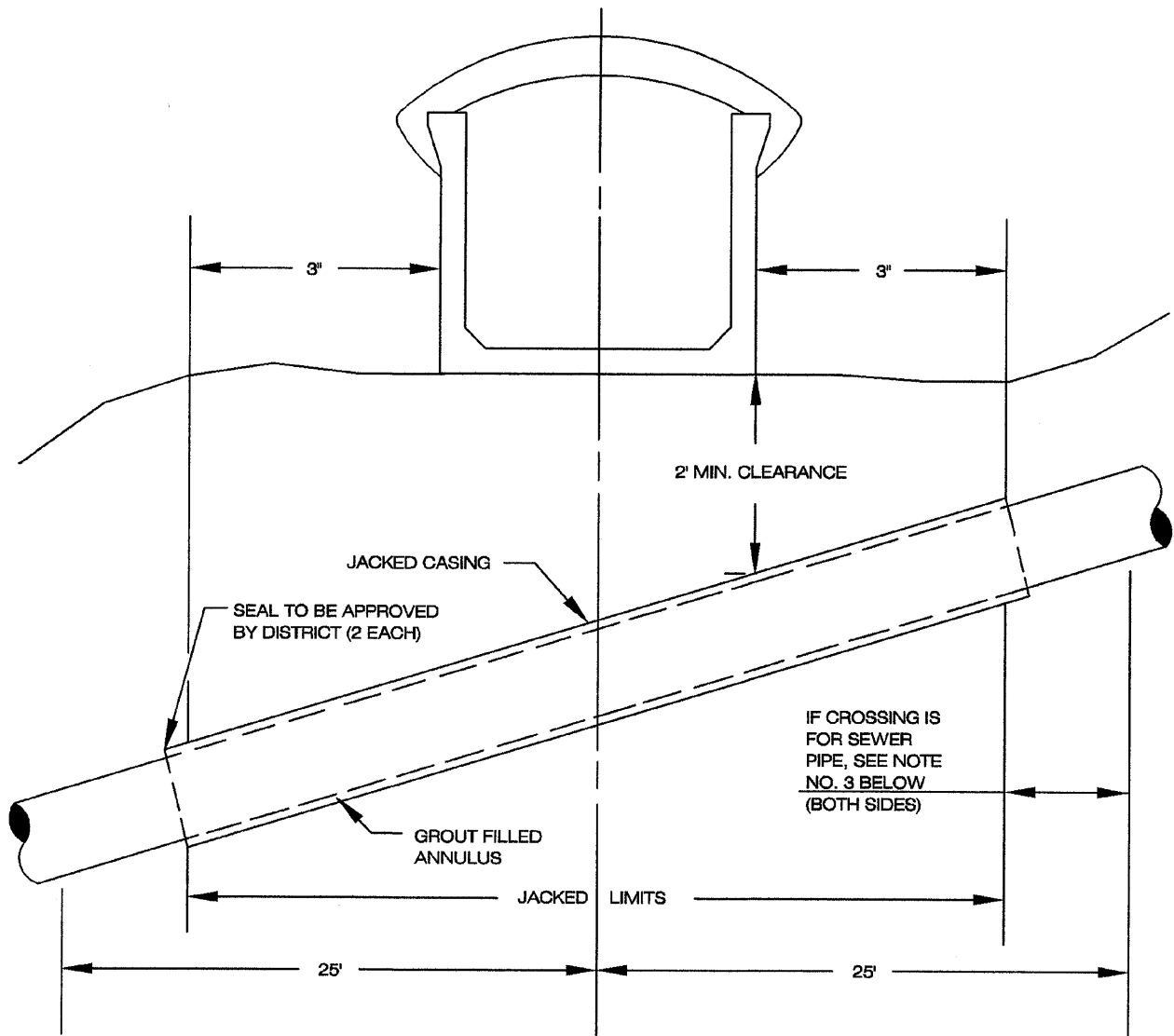

- NOTES: 1 ALL PIPE CROSSING UNDER FLUME SHALL BE INSTALLED IN A 1/4" STEEL CASING JACKED TO MIN. OF 3' FROM EACH SIDE OF THE FLUME AND AT LEAST 2' BELOW THE FLOOR.
- 2 THE ANNULUS BETWEEN THE PIPE AND THE CASING SHALL BE PRESSURE GROUTED WITH SAND-CEMENT GROUT.
- 3 ALL SEWER PIPE, IN ADDITION TO NO. 1 AND NO. 2 ABOVE, MUST BE WELDED STEEL PIPE, 3/16" THICK WITH 1/2" CEMENT LINING AND 1" CEMENT COATING EXTENDING 25' ON EACH SIDE OF THE FLUME CENTERLINE OR ANY SEWER PIPE IN A STEEL CASING 25' FROM EACH SIDE OF THE FLUME CENTERLINE.

REVISIONS	APPROVED	DATE	VISTA IRRIGATION DISTRICT	PATH: (TOM) H:\STD\DWGS\7-7.DWG
			VISTA FLUME AND PIPE CROSSING SEPARATIONS	<i>John Amodeo</i> JOHN AMODEO R. C. E. 31161
				DATE
ACAD		6/96		STANDARD DRAWING 7-7

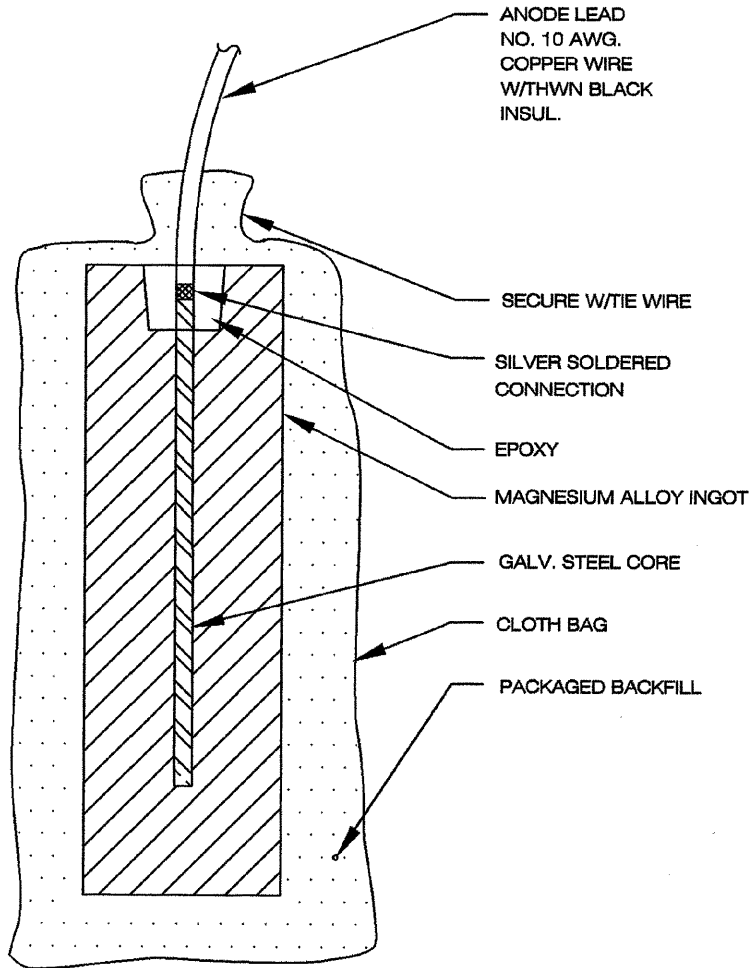

HIGH POTENTIAL

ALLOY SPECIFICATIONS
CHEMICAL COMPOSITION

ELEMENT	AMOUNT
Al	0.010% Max.
Mn	0.50-1.30%
Cu	0.02% Max.
Ni	0.001% Max.
Fe	0.03% Max.
OTHER	0.05% EACH OR 0.30% MAX. TOTAL
Mg	REMAINDER

BACKFILL COMPOSITION

75% GYPSUM
20% BENTONITE
5% SODIUM SULPHATE

INGOT WEIGHT: 48 LBS.
PKGD WEIGHT: 96 LBS. APPROX.

REVISIONS	APPROVED	DATE	VISTA IRRIGATION DISTRICT	PATH: (TOM) H:\STDDWGS\B-1.DWG	
			PREPACKAGED MAGNESIUM ANODE	<i>John A. Amodeo</i> 12/2/97	
				JOHN AMODEO R. C. E. 31161	DATE
ACAD		6/96		STANDARD DRAWING	8-1

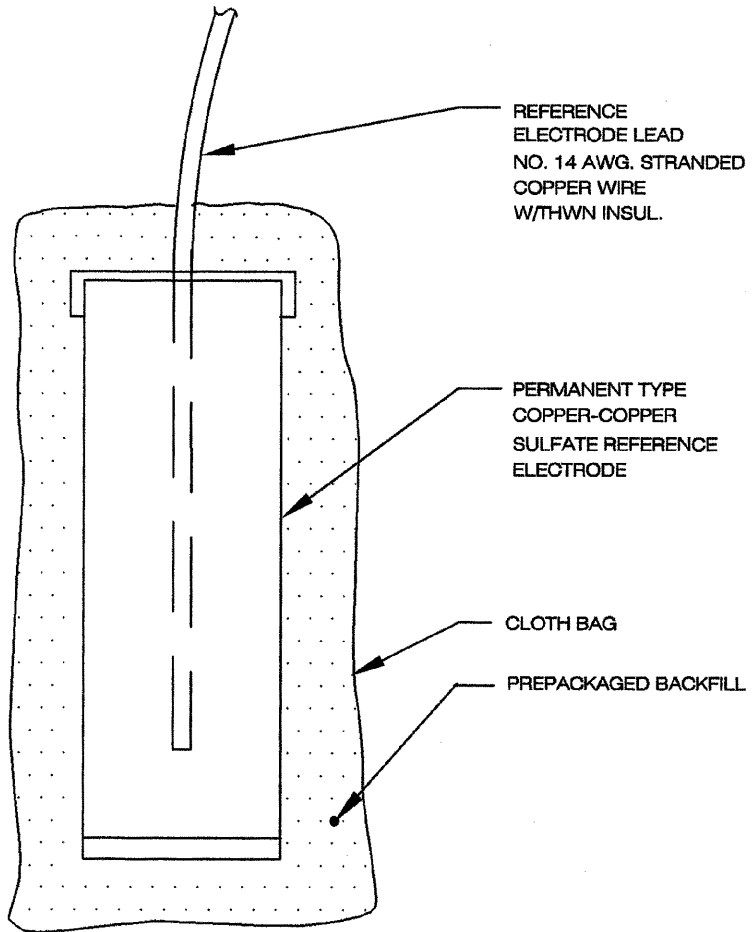

REVISIONS	APPROVED	DATE	VISTA IRRIGATION DISTRICT	PATH: (TOM) H:\STDDWGS\8-3.DWG
			PREPACKAGED COPPER SULFATE REFERENCE ELECTRODE	 JOHN AMODEO R. C. E. 31161
				DATE
				STANDARD DRAWING 8-3
ACAD		6/96		

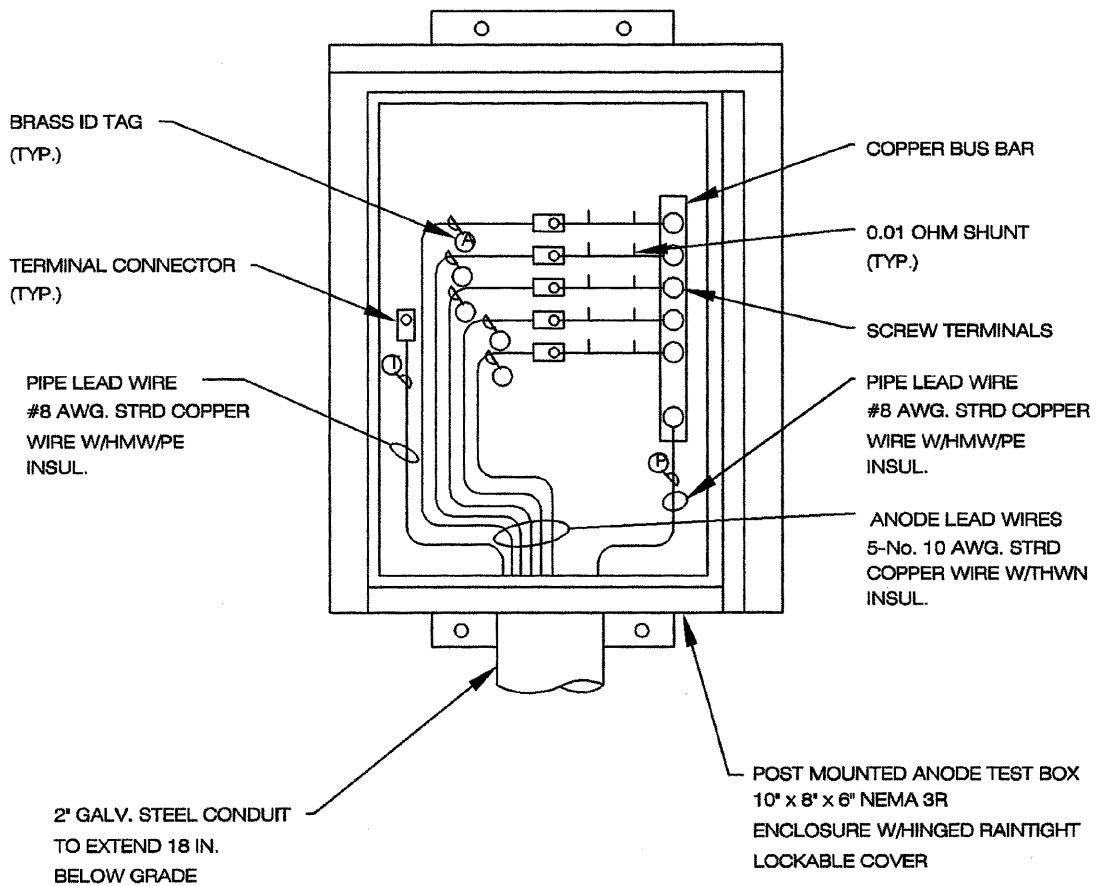

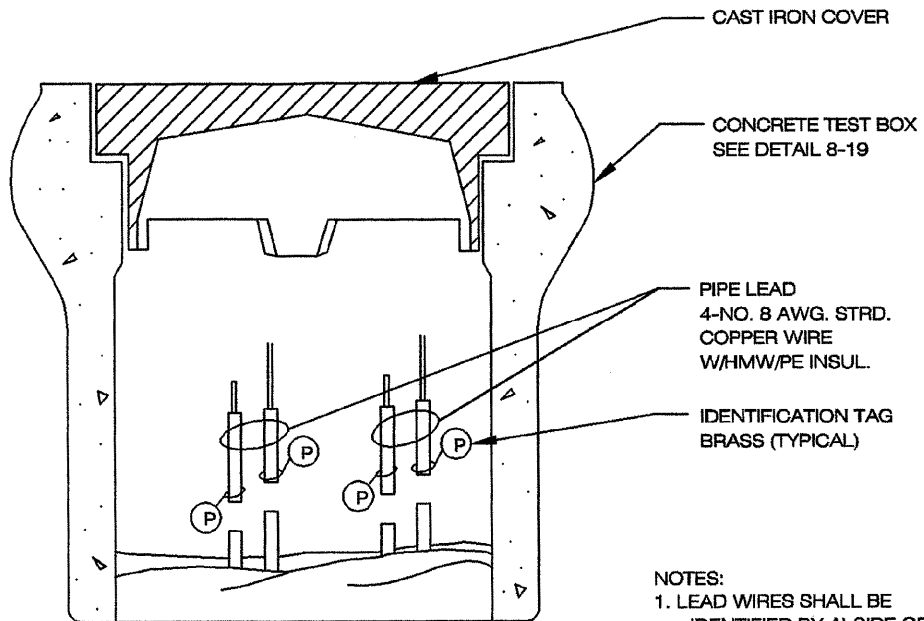
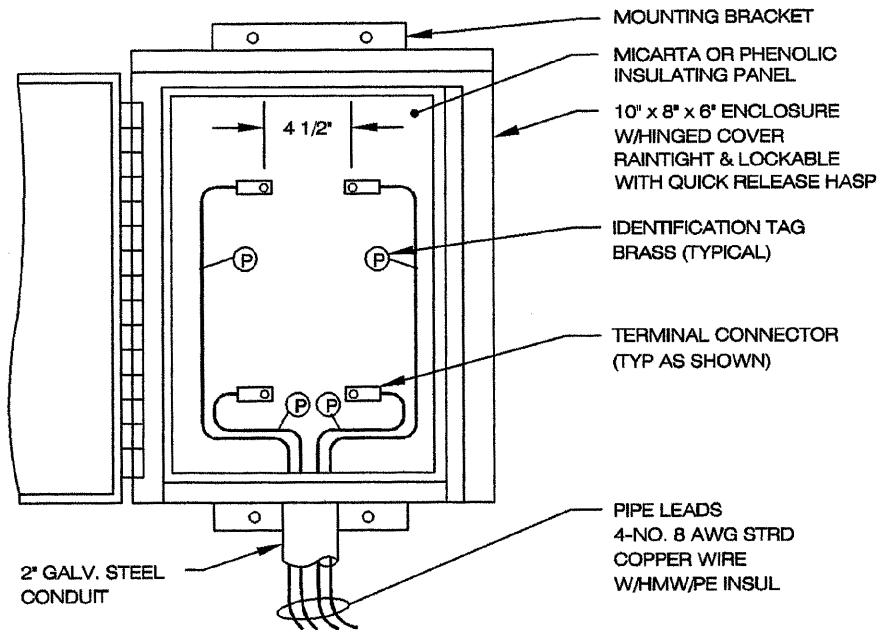

REVISIONS	APPROVED	DATE	VISTA IRRIGATION DISTRICT	PATH: (TOM) H:\STDDWGS\8-4.DWG
			POST MOUNTED ANODE TEST BOX	<i>John A. Amodeo</i> 12/2/96 JOHN AMODEO DATE R. C. E. 31161
				STANDARD DRAWING 8-4
ACAD		6/96		

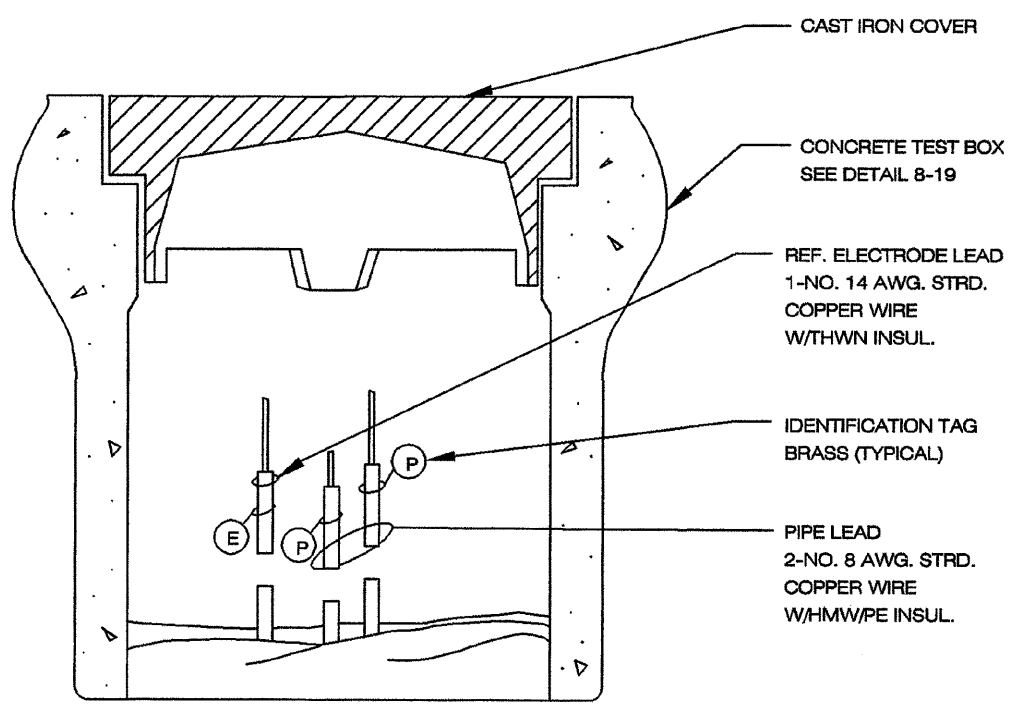
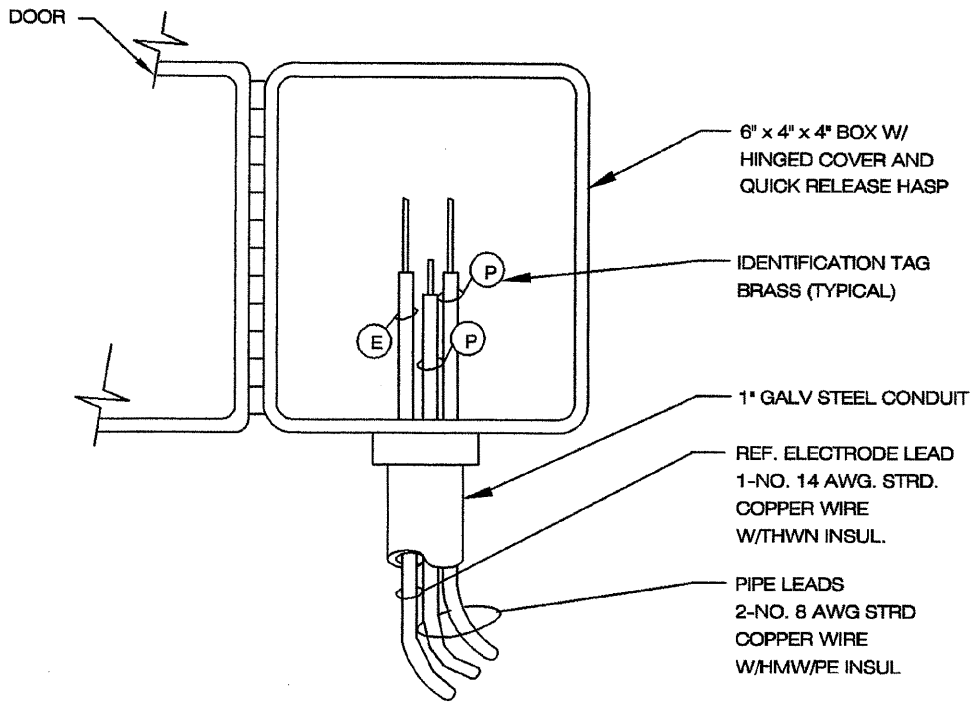

NOTES:
 1. LEAD WIRES SHALL BE IDENTIFIED BY A) SIDE OF INSUL FLANGE AS N & S OR E & W, AND B) DIA. OF PIPE TO WHICH THEY ARE ATTACHED. EG. N20

REVISIONS	APPROVED	DATE	VISTA IRRIGATION DISTRICT	PATH: (TOM) HASTDDWGS\8-5.DWG
			WIRING DIAGRAMS INSULATOR TEST BOXES	 JOHN AMODEO R. C. E. 31161
				STANDARD DRAWING 8-5
ACAD		8/96		



REVISIONS	APPROVED	DATE	VISTA IRRIGATION DISTRICT	PATH: (TOM) H:\STDDWGS\8-7.DWG
			WIRING DIAGRAM TWO WIRE TEST BOXES	 JOHN AMODEO R. C. E. 31161 DATE
ACAD		6/96		

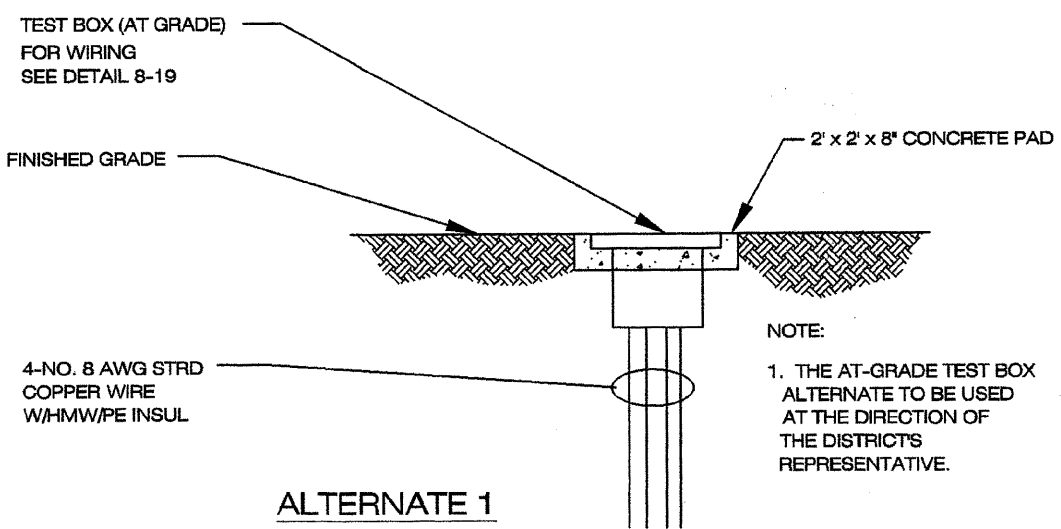
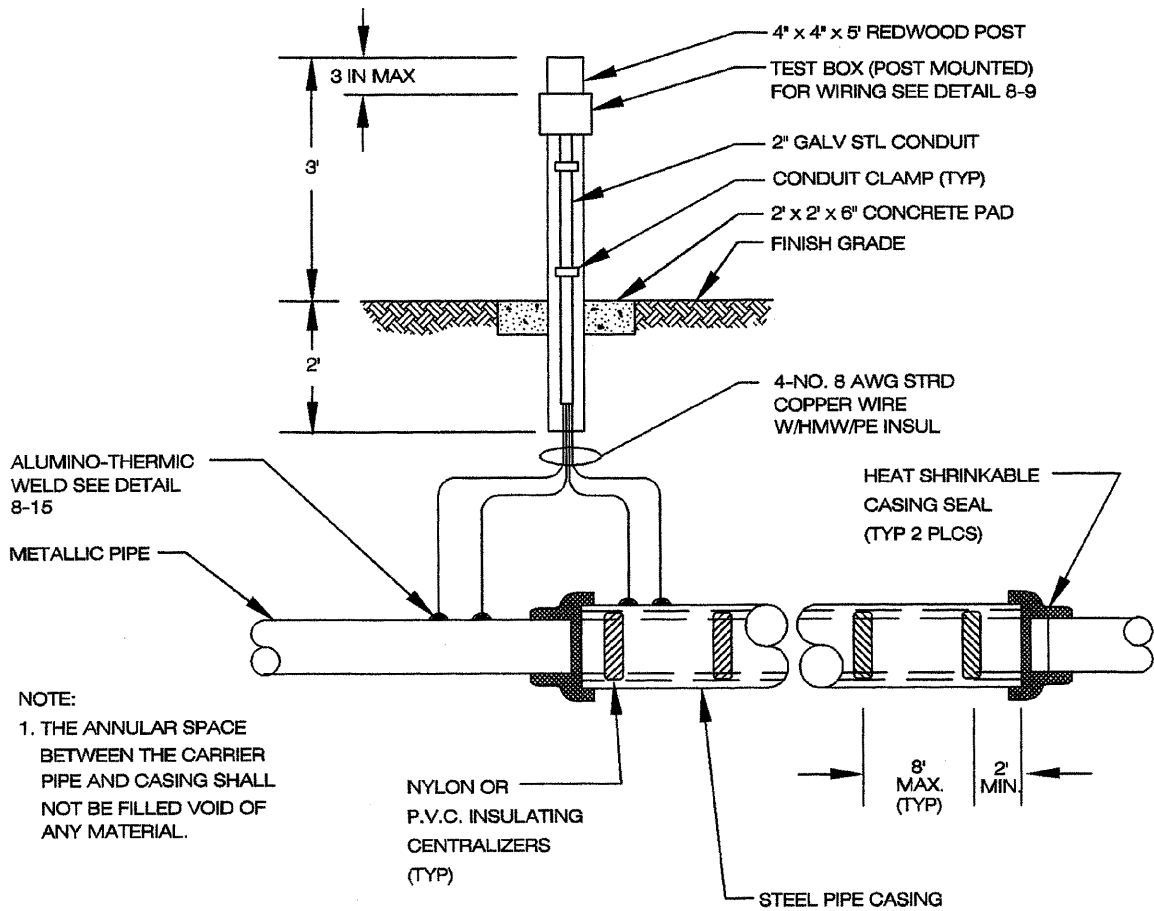

REVISIONS	APPROVED	DATE	VISTA IRRIGATION DISTRICT	PATH: (TOM) H:\STDWGS\8-8.DWG
			CASING TEST BOXES INSTALLATION	<i>John Amodeo</i> 12/2/95
				JOHN AMODEO DATE
				R. C. E. 31161
ACAD		6/96		STANDARD DRAWING 8-8

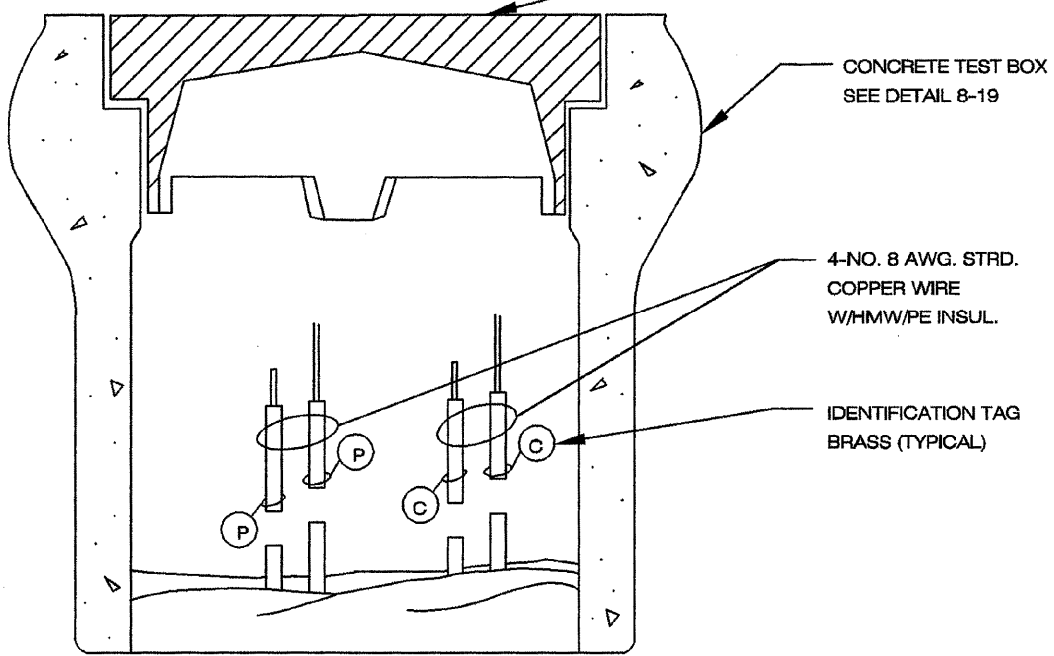
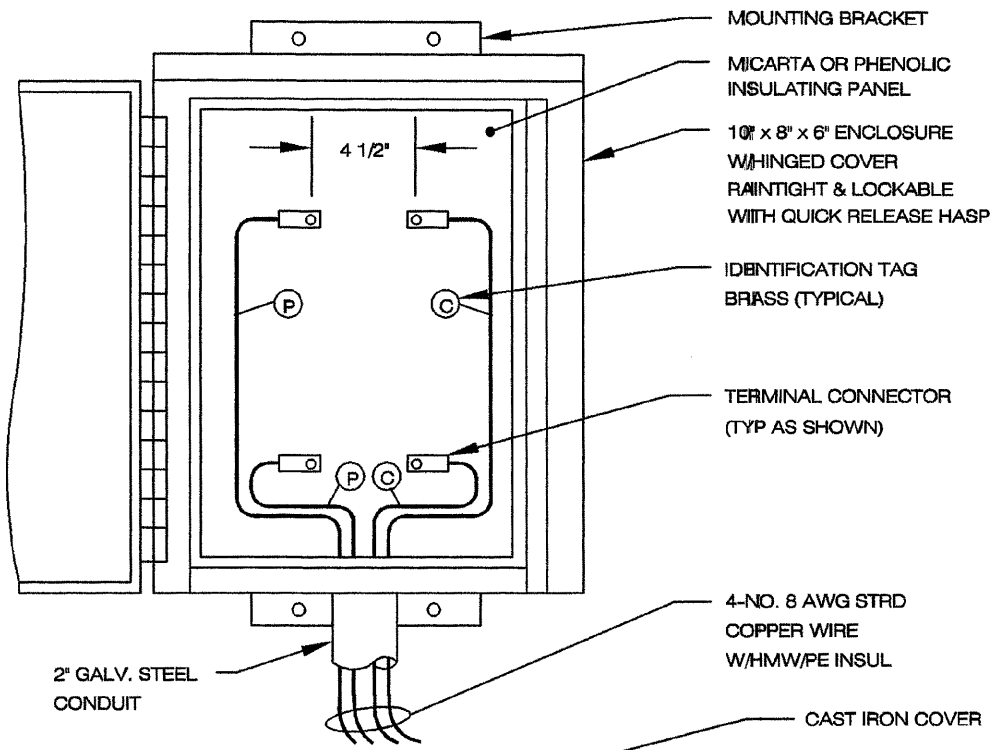

REVISIONS	APPROVED	DATE	VISTA IRRIGATION DISTRICT	PATH: (TOM) H:\STDDWGS8-9.DWG
			WIRING DIAGRAMS CASING TEST BOXES	 JOHN AMODEO R. C. E. 31161
				STANDARD DRAWING 8-9
ACAD		6/96		DATE

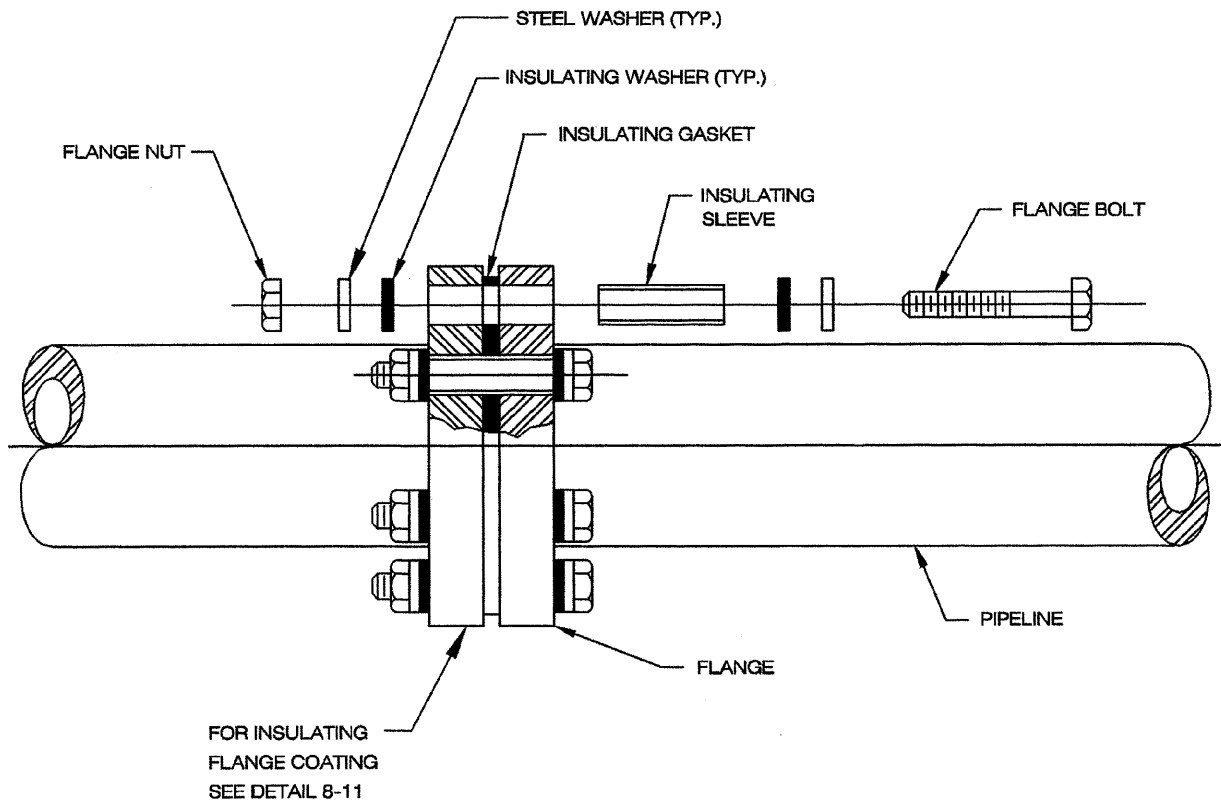

- NOTE:
1. HARDWARE QUANTITIES
IN INSULATING FLANGE
KIT WILL VARY BASED
ON GASKET PATTERN
AND PIPE SIZE.
 2. DO NOT COAT OR SPRAY
INSULATING COMPONENTS
WITH ANY MATERIAL
EXCEPT FOR THOSE
SHOWN IN DETAIL 8-11

REVISIONS	APPROVED	DATE	VISTA IRRIGATION DISTRICT	PATH: (TOM) H:\STDDWGS\8-10.DWG
			INSULATING FLANGE ASSEMBLY	<i>John A. Amodeo</i> 12/2/97
				JOHN AMODEO R. C. E. 31161
ACAD		6/96		STANDARD DRAWING 8-10

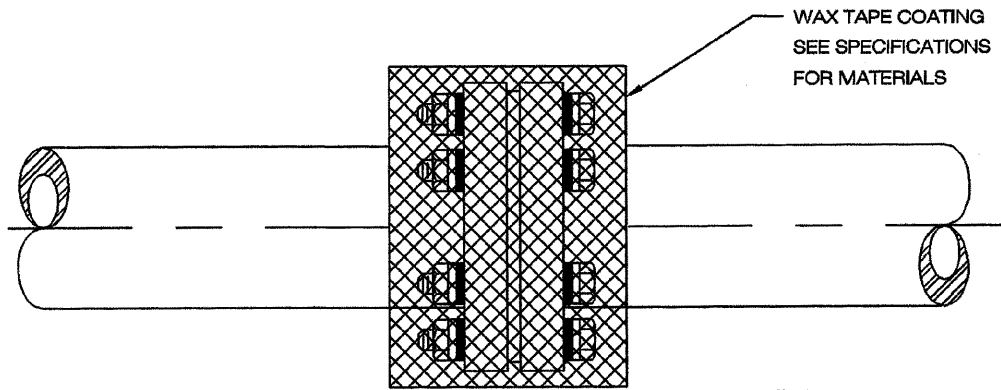

NOTE:
TO BE USED IN BURIED
ASSEMBLIES

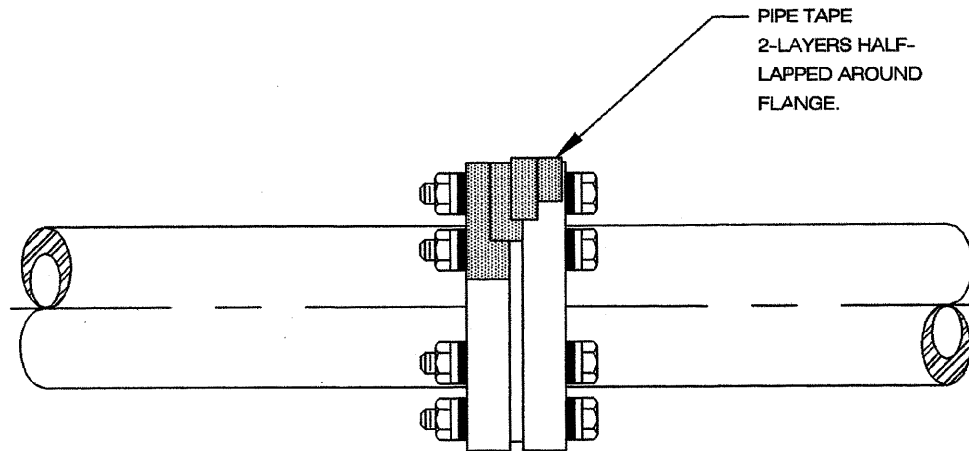

NOTE:
TO BE USED ABOVE GROUND
OR IN VAULT ASSEMBLIES.

REVISIONS	APPROVED	DATE	VISTA IRRIGATION DISTRICT	PATH: (TOM) H:\STDDWGS\8-11.DWG
			INSULATING FLANGE COATING ABOVE AND BELOW GRADE	<i>John A. Amodeo</i> 12/2/95 JOHN AMODEO DATE R. C. E. 31161
				STANDARD DRAWING 8-11
ACAD		6/96		

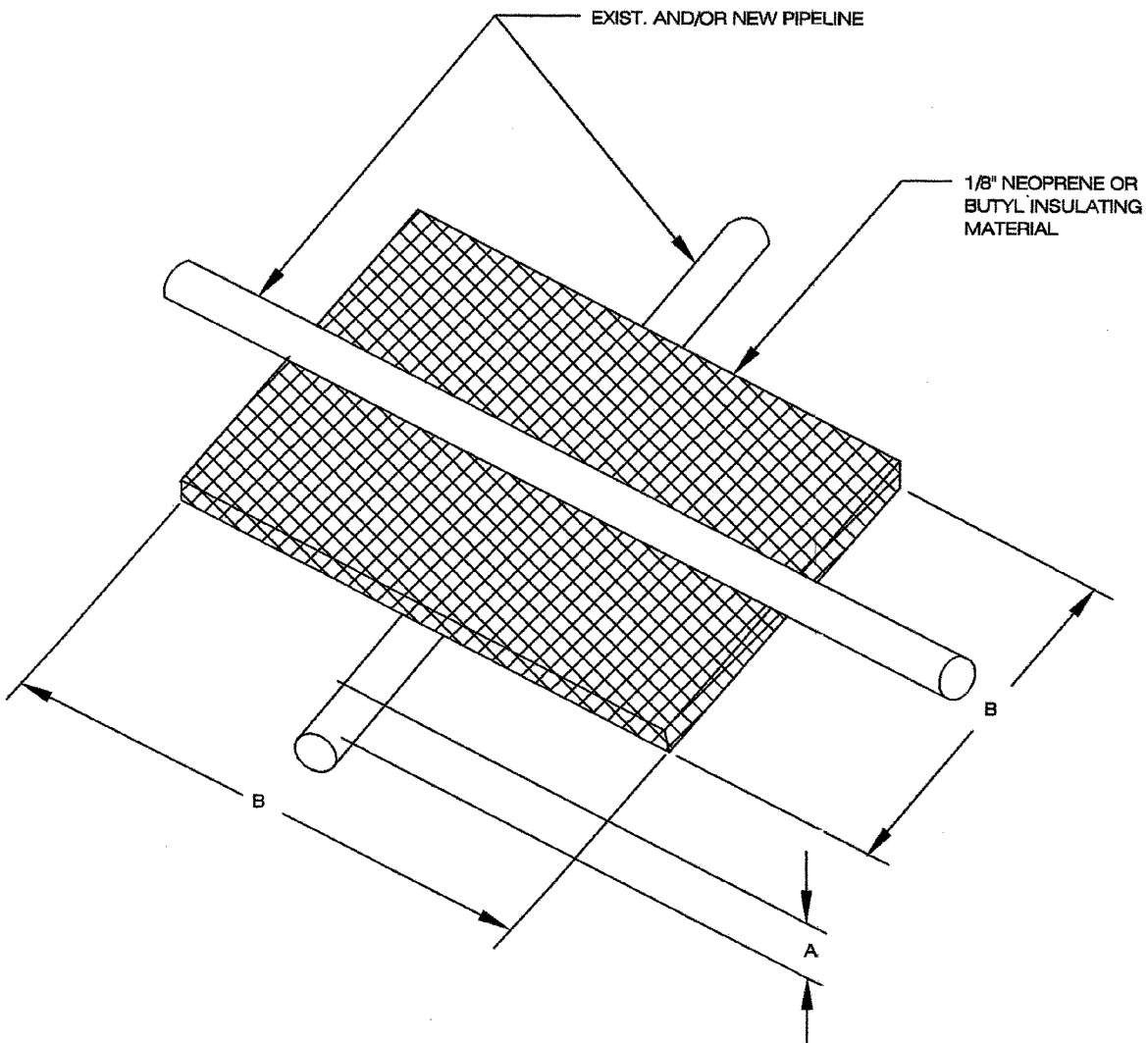

- A. FOR INSTALLATION BETWEEN METALLIC STRUCTURES WHEN DISTANCE IS 18" OR LESS
- B. INSULATING BLANKET SHALL BE 12" LARGER THAN THE LARGEST PIPE DIAMETER.

REVISIONS	APPROVED	DATE	VISTA IRRIGATION DISTRICT	PATH: (TOM) H:\STDDWGS\8-12.DWG
			INSULATING BLANKET	<i>John A. Amodeo</i> 12/2/95
				JOHN AMODEO R. C. E. 31161
ACAD		6/96		STANDARD DRAWING 8-12

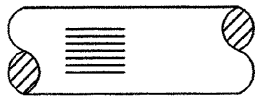
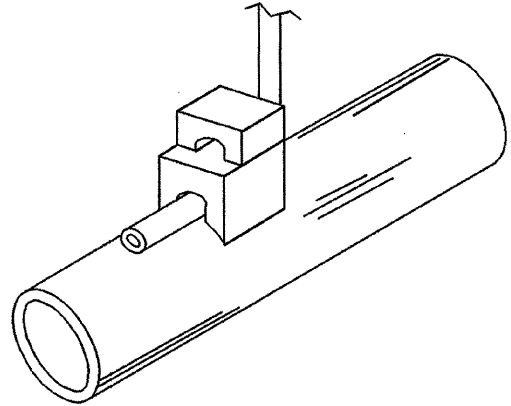
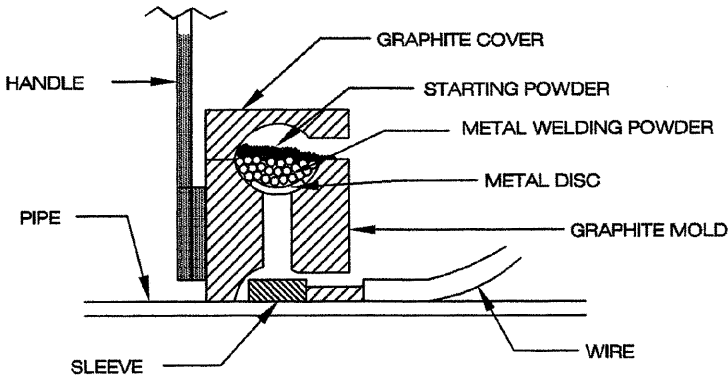

STEP 1.

FILE STRUCTURE CONNECTION AREA (3 IN. x 3 IN.) TO BARE SHINY METAL AND CLEAN.

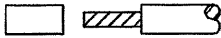

STEP 2.

STRIP INSULATION FROM WIRE. ATTACH SLEEVE (REQUIRED ON NO. 8 AWG WIRE OR SMALLER).

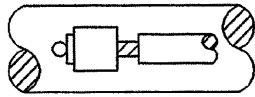

STEP 3.

HOLD MOLD FIRMLY WITH OPENING AWAY FROM OPERATOR AND IGNITE WITH FLINT GUN.

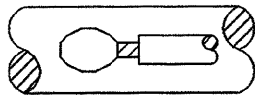

STEP 4.

REMOVE SLAG FROM CONNECTION AND PEEN WELD FOR SOUNDNESS.

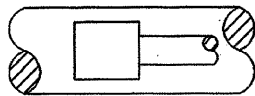

STEP 5.

COVER CONNECTION AND EXPOSED STRUCTURE SURFACE WITH A BITUMINOUS COATING COMPOUND. PLACE PLASTIC SHIELD CAP FIRMLY OVER CONNECTION.

NOTES:

1. ALL WIRE WELDS SHALL BE MINIMUM 6 INCHES APART.
2. STANDARD WELD CARTRIDGES SHALL BE USED FOR STEEL SURFACES, FOR DUCTILE IRON AND CAST IRON, USE XF-19 ALLOY OR EQUIVALENT.
3. WELDER SHOWN IS FOR HORIZONTAL SURFACES, FOR VERTICAL SURFACES, SIDE WELDER IS REQUIRED.
4. ALL EXPOSED METAL STRUCTURE, WIRE, WELD, SHALL BE COATED WITH BITUMINOUS COMPOUND.

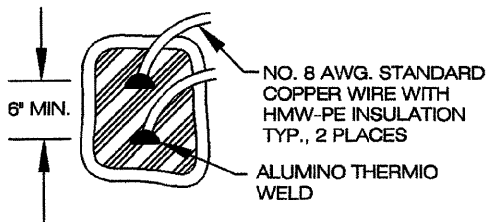

NOTE: WELD TEST STATION WIRES AT PIPE JOINTS WHENEVER POSSIBLE

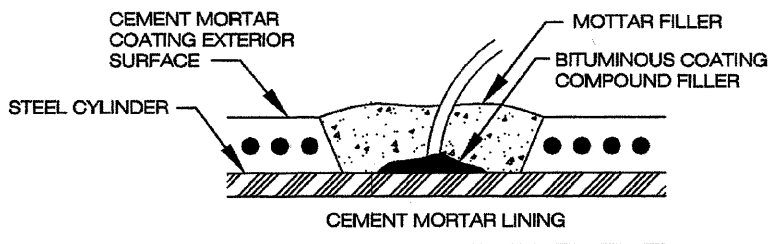

WIRE CONNECTION DETAIL FOR MORTAR COATED STEEL PIPE

REVISIONS	APPROVED	DATE	VISTA IRRIGATION DISTRICT	PATH: (TOM) H:\STDDWGS\8-15.DWG
			ALUMINO-THERMIC WELD	<i>John A. Amodeo</i>
				JOHN AMODEO
				R. C. E. 31161
ACAD		6/86		STANDARD DRAWING 8-15

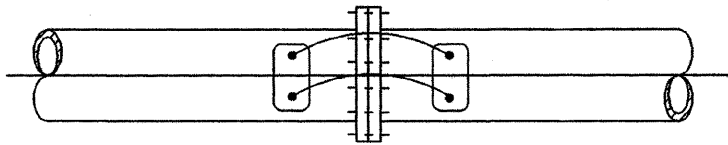

FLANGED OR MECHANICAL PIPE JOINT

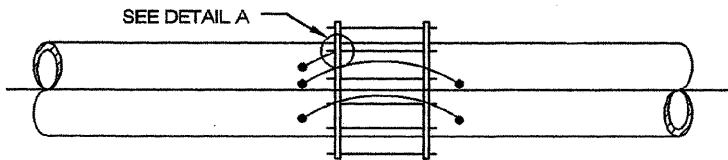

FLEXIBLE COUPLING PIPE JOINT

NOTES:

1. ALL BOND WIRES SHALL BE NO. 4 AWG. STRD. COPPER WIRE W/HMPE INSULATION, INSTALLED AT MIN. LENGTH.
2. ALL WIRE CONNECTIONS SHALL BE MADE BY THE ALUMINO-THERMIC WELD PROCESS, PER DETAIL W15 AND ALL WIRE WELDS SHALL BE 6 INCHES APART MINIMUM.
3. THREE BOND WIRES ARE REQUIRED FOR PIPE DIAMETERS 18" AND LARGER, AND TWO BOND WIRES ARE REQUIRED FOR ALL SMALLER DIAMETERS.
4. BOND WIRES SHALL NOT BE INSTALLED ACROSS INSULATING JOINTS.

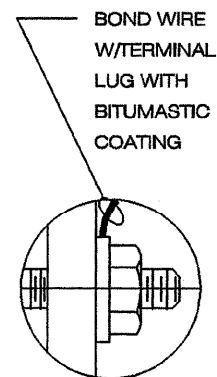

DETAIL A

WIRE CONNECTION TO FLANGE BOLT

REVISIONS	APPROVED	DATE	VISTA IRRIGATION DISTRICT	PATH: (TOM) H:\STDDWGS\8-16.DWG
			JOINT BONDING	 JOHN AMODEO DATE R. C. E. 31161
ACAD		6/96		

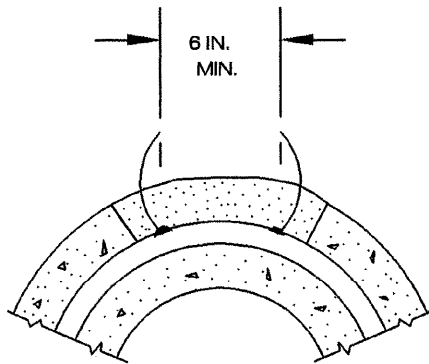
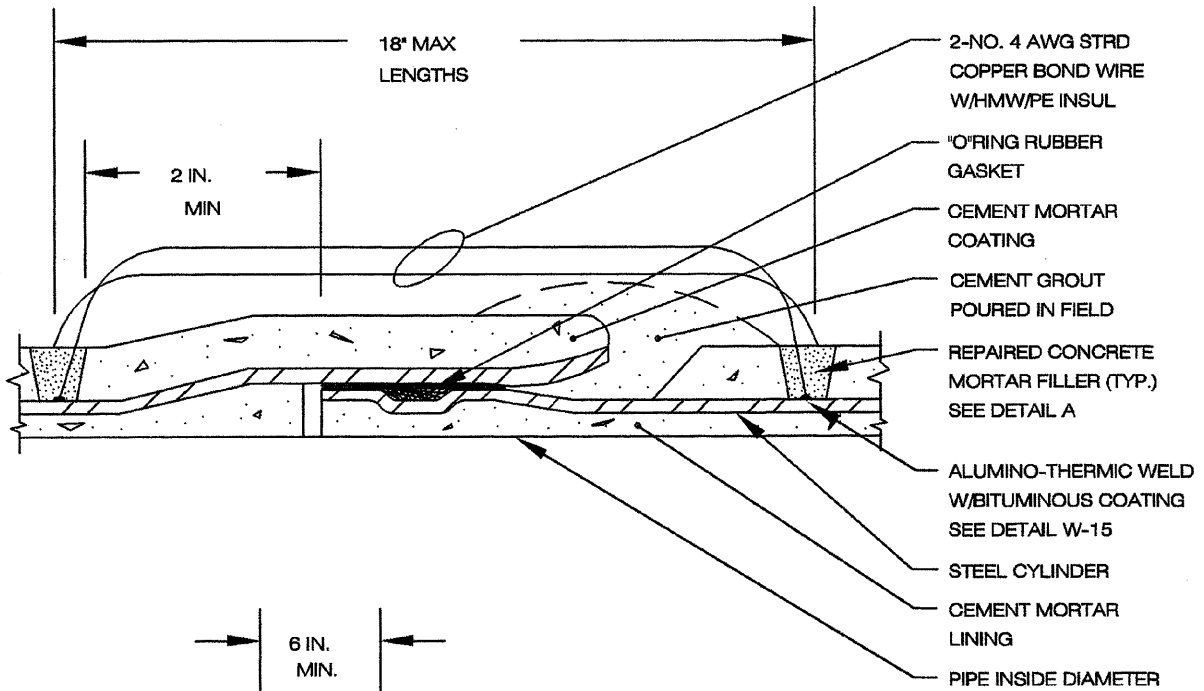

DETAIL A

NOTE:
 1. THREE BOND WIRES ARE REQUIRED FOR PIPE DIAMETER 18" AND LARGER, TWO BOND WIRES ARE REQUIRED FOR SMALLER DIAMETERS.

REVISIONS	APPROVED	DATE	VISTA IRRIGATION DISTRICT	PATH: (TOM) H:\STDDWGS\8-18.DWG
			JOINT BOND REPAIR	 JOHN AMODRO DATE R. C. E. 31161
				STANDARD DRAWING 8-18
ACAD		6/96		

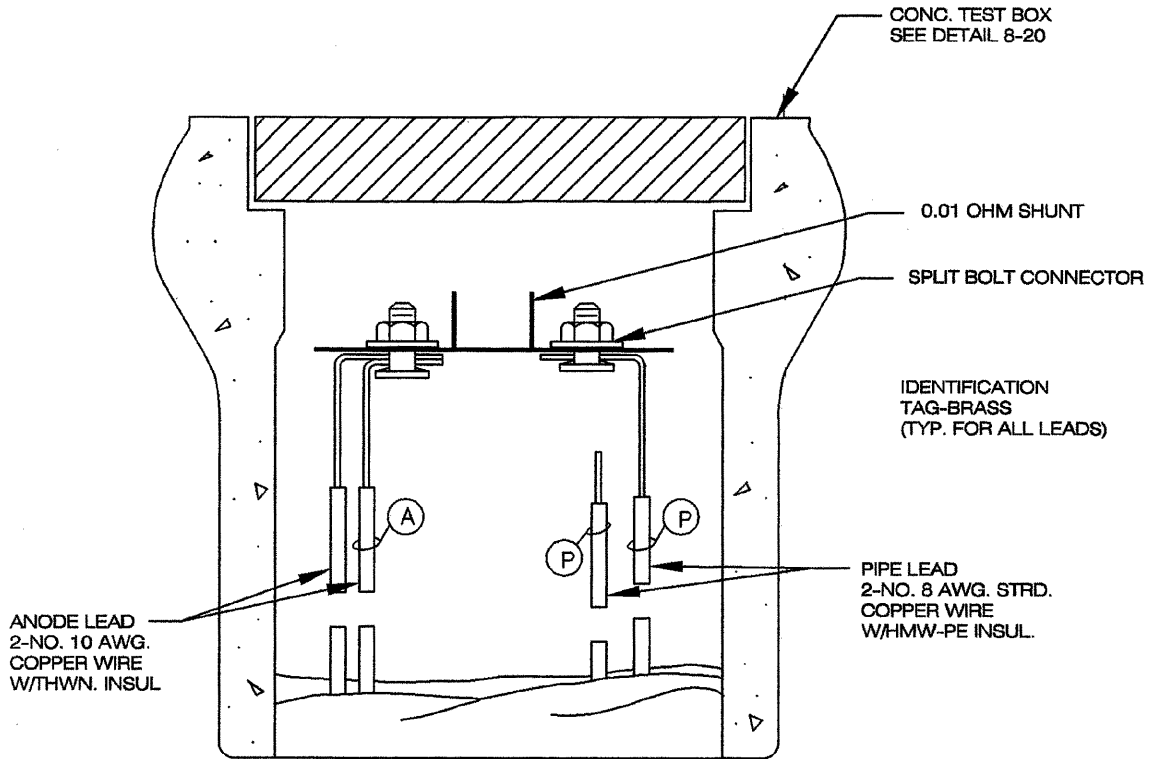

NOTES

1. ALL SPLIT-BOLT CONNECTIONS SHALL BE TAPE WRAPPED
2. NUMBER OF ANODE LEAD WIRES ENTERING BOX MAY VARY PER INSTALLATION.

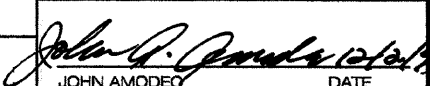
REVISIONS	APPROVED	DATE	VISTA IRRIGATION DISTRICT	PATH: (TOM) H:\STDDWGS\8-21.DWG
			AT-GRADE ANODE TEST BOXES	 JOHN AMODEO DATE R. C. E. 31161
				STANDARD DRAWING 8-21
ACAD		6/96		

